

alpha Linear Systems

Product catalog

Dynamic
Precise
Individual



alpha Linear Systems Product catalog

Dynamic
Precise
Individual

© 2020 by WITTENSTEIN alpha GmbH

All technical specifications were correct at the time of going to print. We are continually developing our products and therefore reserve the right to make modifications. This documentation is subject to occasional errors. Please appreciate that legal claims cannot be asserted as a result of incorrect specifications, illustrations or descriptions. The text, photos, technical drawings and any other illustrations printed in this publication are protected property of WITTENSTEIN alpha GmbH.

Further use of this material in printed or electronic format requires express approval from WITTENSTEIN alpha GmbH.

Any form of duplication, translation, editing, transfer to microfilm or storage on electronic systems is not permitted without express permission from WITTENSTEIN alpha GmbH.

Foreword by company management 06

WITTENSTEIN alpha 08

More than 35 years of innovation

alpha Linear Systems 12

Value Linear Systems 30

Advanced Linear Systems 46

Premium Linear Systems 78

Rotary Solutions with spur toothing 106

System Accessories 116

| | | | |
|---------------------------------------|-----|----------------------------|-----|
| Lubrication system | 116 | Assembly accessories | 128 |
| Lubricating pinion | 118 | Standard rack installation | 129 |
| Lubricator LUC+125 | 120 | INIRA® rack assembly | 130 |
| Lubricator LUC+400 | 122 | | |
| Lubrication system accessories | 124 | | |
| Lubrication pinions and mounting axis | 125 | | |

Information 132

| | | | |
|---------------------------------|-----|-------------------|-----|
| Glossary | 132 | Rack | 150 |
| Compendium | 136 | WITTENSTEIN Group | 154 |
| Gearbox/servo actuator overview | 144 | | |



Dear Business Associates,

Even though we are extremely passionate about technology and innovation, the success of our customers is our top priority. We have designed our products and services to help you achieve a competitive advantage – through consistently high quality, permanent availability and the best service worldwide.

Our linear systems always focus on maximized efficiency for the customer. We are consistently rethinking our proven solutions. One example is INIRA® pinning, which has set completely new standards in pinning and revolutionized rack installation. Unique software tools such as cymex® create the perfect foundation for designing both linear systems and individual products. Our extensive know-how makes us a partner you can always rely on.

You are sure to find the right solution quickly and easily from our product range. We offer complete mechanical and mechatronic drive solutions for all types of axis. We also provide complete solutions from a single source on request. Our range of products and solutions will continue to grow in the future because we never stop developing new ideas to make your work easier.

Take our word for it!

Thomas Patzak and Norbert Pastoors
Managing Directors WITTENSTEIN alpha GmbH

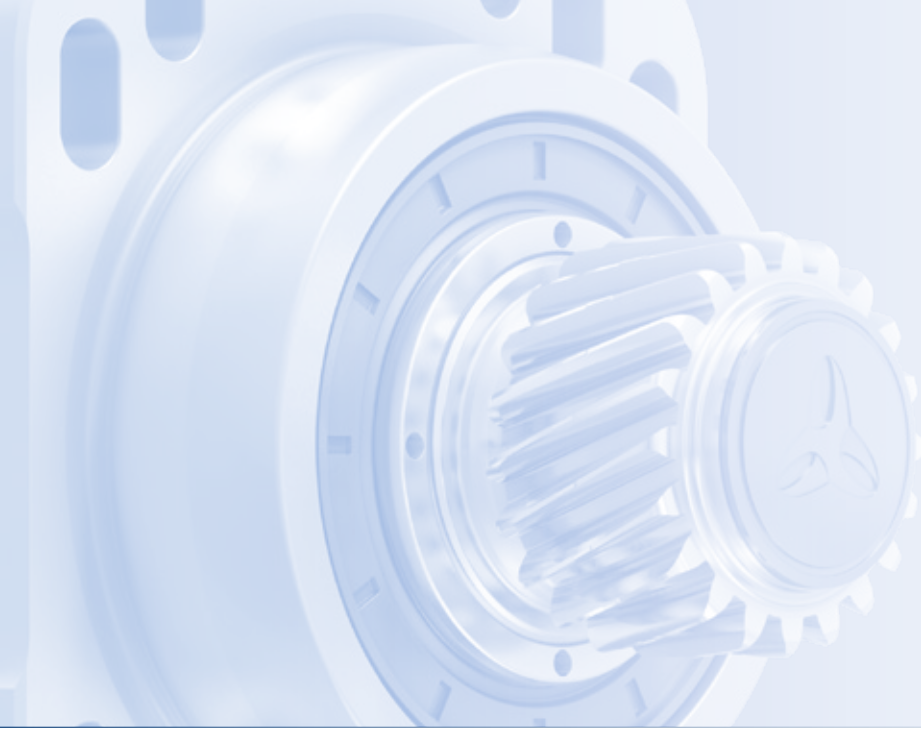

We think ahead – for solutions and services that make the difference:



INIRA® – the revolution in rack assembly

INIRA® combines our existing innovative concepts for the simple, safe and efficient assembly of racks. Learn more on page 24.



cymex® 5 – the standard in design software

cymex® 5 allows the efficient dimensioning and layout of complete drive trains (application + linear system + motor). The individual requirements can be realized almost without limits. Learn more on page 26.



Our range of services – tailored to your specific requirements

We are also setting new standards in customer support with our sizing, commissioning, maintenance and training services from WITTENSTEIN alpha. Learn more on page 28.

YOUR WORLD IS OUR DRIVE.

FOR MORE THAN 35 YEARS.



SP



LP



Linear systems



TPM+



High Performance Linear System

1983

1994

1996

1999

2002

2004

2006

2007

2011

2013

TP



cymex®
sizing software



XP+ / TP+ / SP+ / LP+



TPK+ / SPK+ /
HG+ / SK+ / TK+



HDV
Hygienic Design



PERFORMANCE

Performance where it counts:
High torque, outstanding precision and high power density – essential for our products and systems.

FUTURE PROOF

We live processes:
Only those who know the exact details of customer processes and requirements are in a position to develop solutions that offer added value in the short and long term.

SCALABILITY

You never make compromises:
Whatever the performance area – we offer solutions that grow with your requirements.



WITTENSTEIN

alpha

It is good to know today what will be needed tomorrow. Applying it in practice is even better. We develop technology that shapes the future – ENGINEERING FUTURE SOLUTIONS.

EFFICIENCY

We like it „lean“:
We offer products and systems that are energy-efficient and require minimal installation space in machines.

AVAILABILITY

You need reliability:
We have the widest range of products on the market and can implement your application „just in time“.

CONNECTIVITY

We think in terms of interfaces:
All of our systems can be integrated in a wide range of peripherals.



alpha Value Line



DP+ for Delta robots



INIRA®



alpha Linear Systems



alpha Basic Line

2015

2016

2017

2018

cymex® 5



SIZING ASSISTANT



V-Drive Family



premo®



CAD POINT



WITTENSTEIN alpha on all axes

Complete drive solutions under one roof

We offer the best solutions for almost every application. In addition to gearboxes, our product portfolio includes a wide range of drive solutions with linear systems and servo actuators. Adapted accessories such as couplings and shrink disks round off the product portfolio.

The diagrams below provide a quick overview of our product portfolio for a wide variety of requirements and applications:

Planetary gearboxes

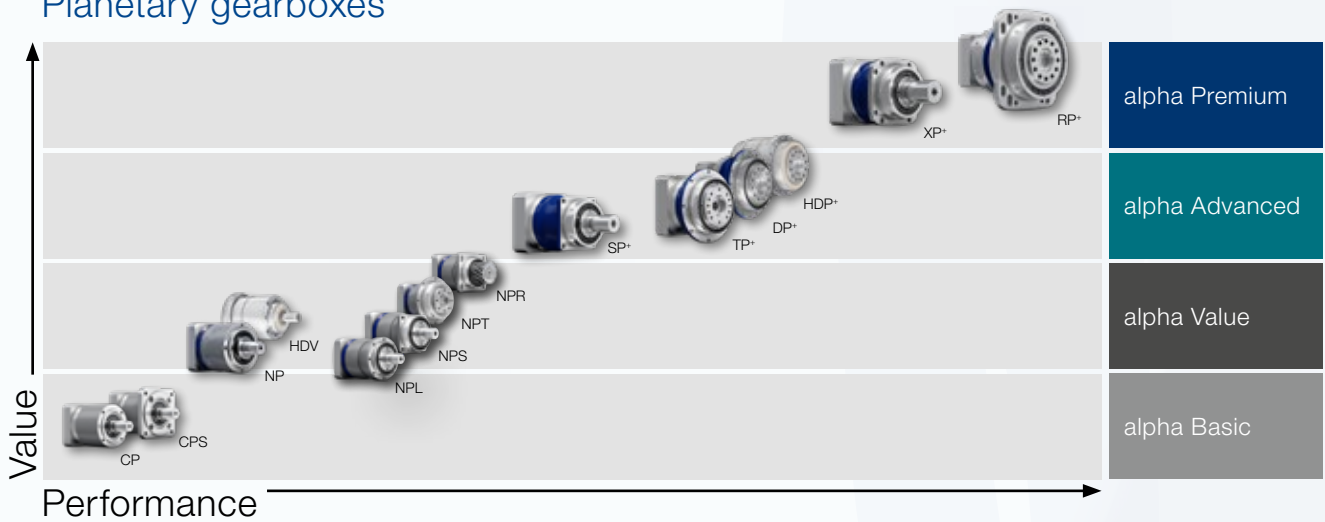

Hypoid, bevel and worm gearboxes



Know-how in every sector

Our solutions range from high-precision axes in manufacturing systems to packaging machines which must operate at maximum productivity in the smallest installation space.

Overview:

- Machine tools and production technology
- Food and packaging machines
- Wood working machinery
- Printing and paper machines
- Robotics and automation

Linear systems

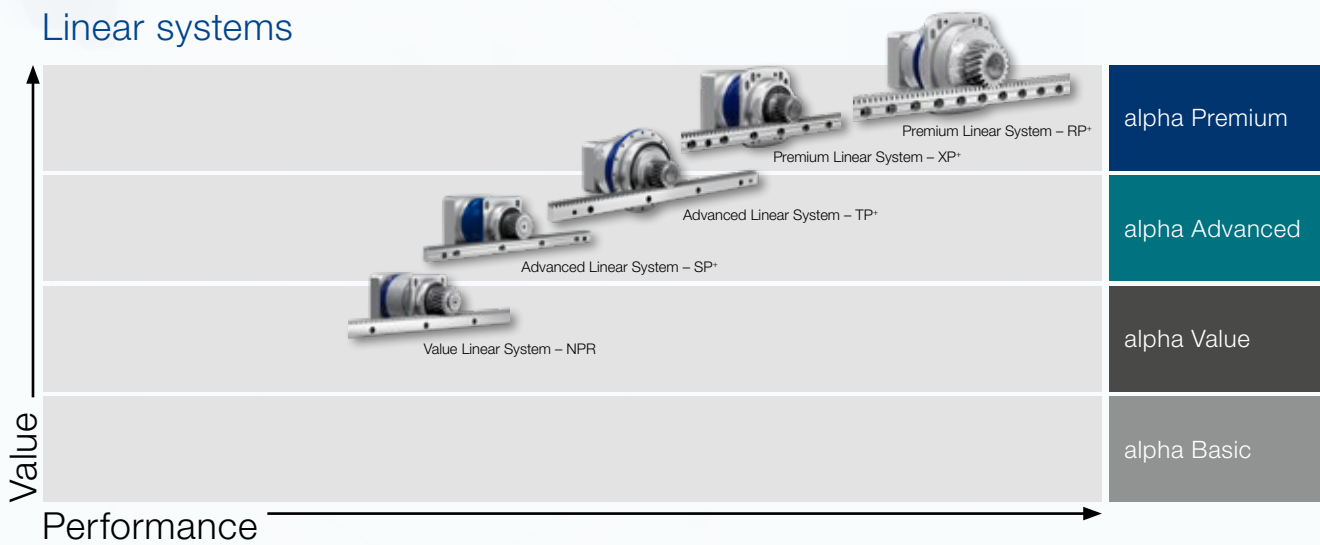

Servo actuators

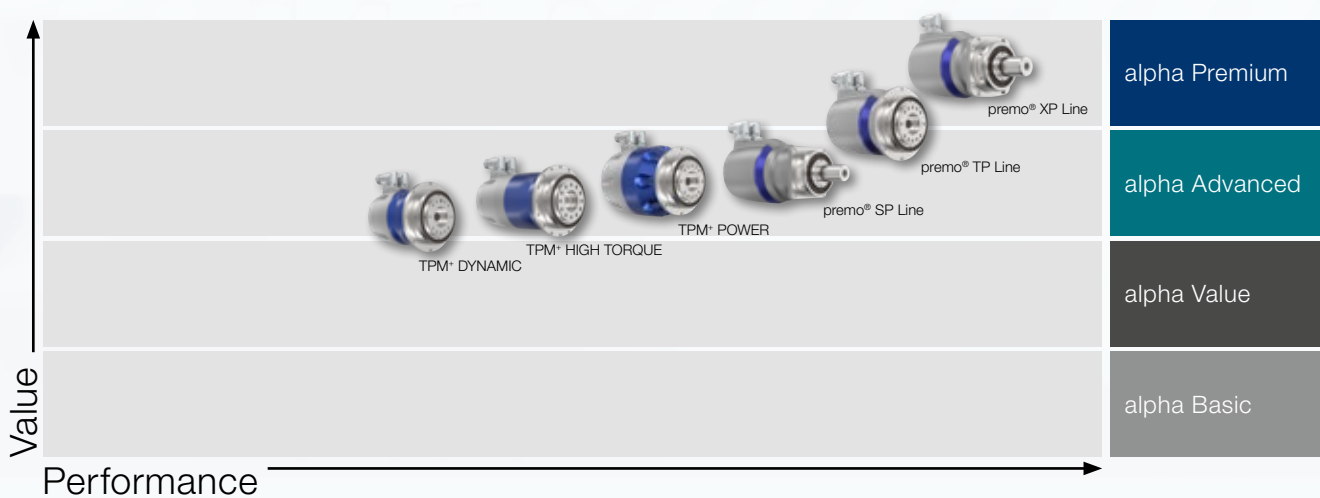

Linear systems from WITTENSTEIN alpha – the perfect symbiosis of state-of-the-art technology and many years of experience.

System solutions count

Our unique knowledge extends from the coupling of gearboxes, motors, pinions and racks to outstanding system solutions. We offer solutions perfectly designed to meet your specific needs in terms of the smooth running, positioning accuracy and feed force of linear drives.

Benefit from maximum performance across the board:

- Maximum precision
- Highest dynamics
- Optimum rigidity
- Maximum service life

Our linear systems are the result of more than 35 years of experience in the fields of gearbox design, toothing technology and the dimensioning of complete drive systems.

For a wide range of applications

Linear systems of WITTENSTEIN alpha are suitable for a wide range of applications and industries. New standards and advantages have been achieved in the following areas:

- Smooth running
- Positioning accuracy
- Feed force
- Power density
- Rigidity
- Ease of installation
- Structural design
- Scalability

Paired with a comprehensive range of services, we pledge to support you from the initial concept design to the installation and commissioning phase. Additionally we ensure a seamless supply of spare parts.

Your benefits at a glance

- Perfectly matched components
- Maximum efficiency and power density
- Exceptional linear system rigidity for even greater dynamics and precision
- Simple mounting and perfect integration in the drive train
- Available in different sizes, power categories and segments

Consultation and quality – everything from a single source!



The right linear system for every application

Value Linear Systems



The Value Linear Systems are adapted to linear applications in the Value Segment with comparatively low requirements in terms of smooth running, positioning accuracy and feed force. The R-flange of the Premium Segment now provides greater design freedom in the Value Segment.

Typical fields of application include wood working machinery, plasma cutting systems and automation.



Advanced Linear Systems

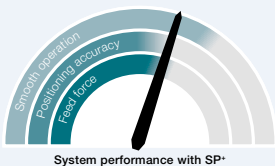

These systems are adapted to applications with average to high demands in terms of smooth running, positioning accuracy and feed force. Different gearbox versions and options such as HIGH TORQUE or HIGH SPEED can be selected to utilize the most appropriate system for the application. Typical fields of application include wood, plastic and composite machining, machining centers and automation.

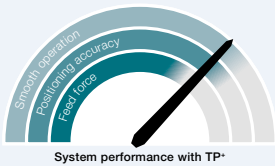

Premium Linear Systems

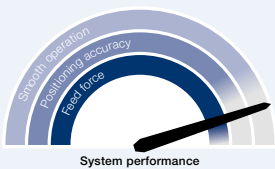

The Premium Linear Systems are adapted specifically to applications with extremely high demands in terms of smooth running, positioning accuracy and feed force. They offer drives with an outstanding power density, maximum linear system rigidity and extreme precision both in a

single drive and master/slave configuration for maximum design freedom. The option of downsizing also offers savings potential in the drive train. Typical fields of application include laser machines, wood, plastic and composite machining centers, cutting machine tools, e.g. HSC milling machines as well as highly dynamic precision handling applications.



The full array of linear systems

In addition to the standard planetary gearboxes, the respective servo worm and servo right-angle gearboxes are also available for our rack and pinion systems. The integrated TPM⁺, RPM⁺ and premo[®] motor/gearbox units round off the portfolio. Refer to the respective product catalogs for further information.

The alpha preferred linear system – The best of each segment

Our preferred linear systems are always comprised of the perfect combination of gearbox, pinion, rack and lubrication system. The systems are optimized with focus on the degree of utilization of the individual components, feed force, feed speed and rigidity.

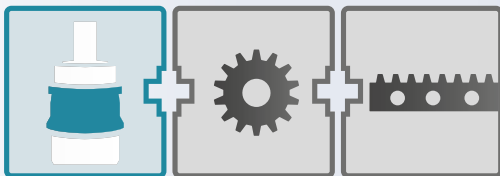

Linear Systems

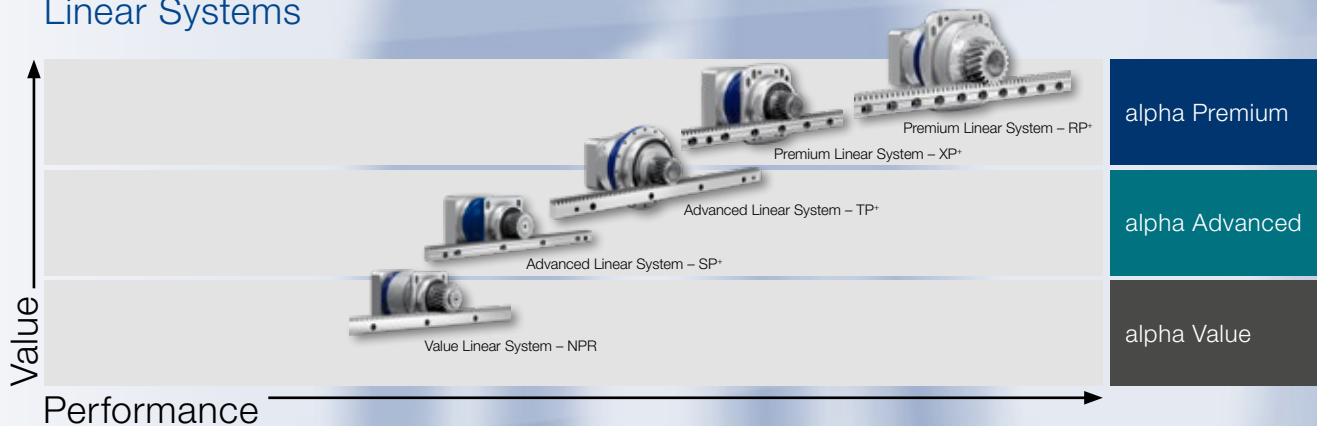

WITTENSTEIN alpha – suitable for all axes

We offer complete linear drive solutions for each axis from a single source. The fields of application of our linear systems are nearly unlimited, ranging from automation solutions to high-precision axes in machine tools and manufacturing systems which are required to achieve maximum productivity. We always stand as a synonym for the highest quality and reliability, extremely smooth running and high positioning accuracy and feed force combined with maximum power density and outstanding rigidity. Our linear systems offer innovative drive and assembly solutions.



User-friendly assembly solutions

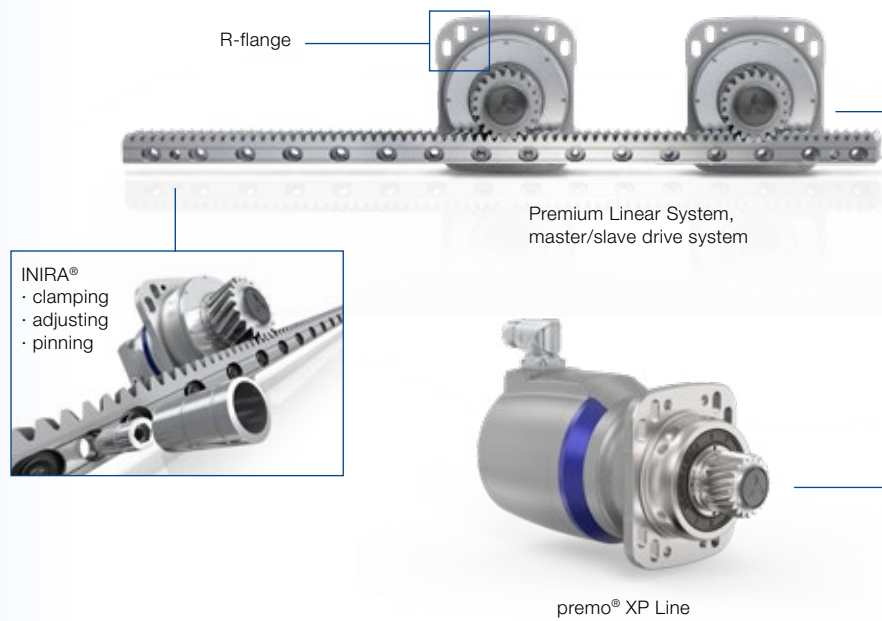

References across all segments



7th Axis
Source: YASKAWA Nordic AB



Pipe bending machine
Source: Wafios AG



CNC machining centers for wood, plastic and composite materials
Source: MAKA Systems GmbH

Exemplary product solutions in a portal milling machine



Premium Linear System with RPM+



Value Linear System with NPR

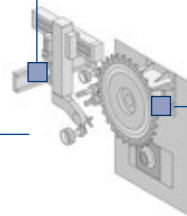
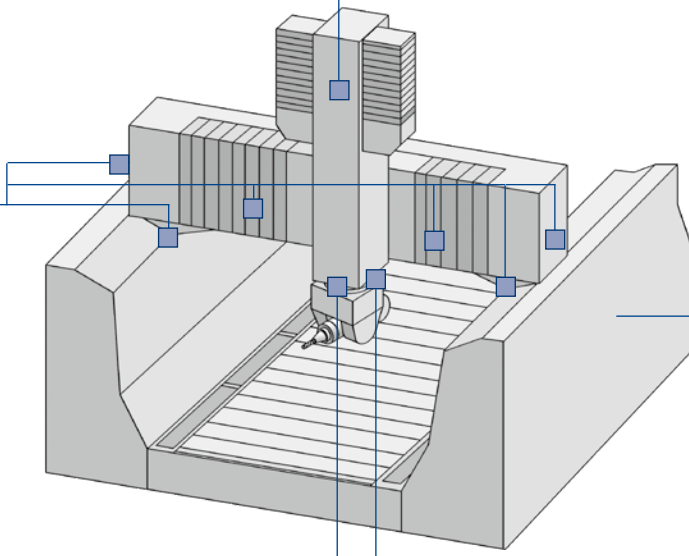

premo® TP Line



Galaxie® drive system



Lubrication system for all axes



Flatbed laser
Source: Yamazaki Mazak Corporation



Press transfer
Source: Strothmann Machines & Handling GmbH



HSC portal milling machine
Source: F. Zimmermann GmbH



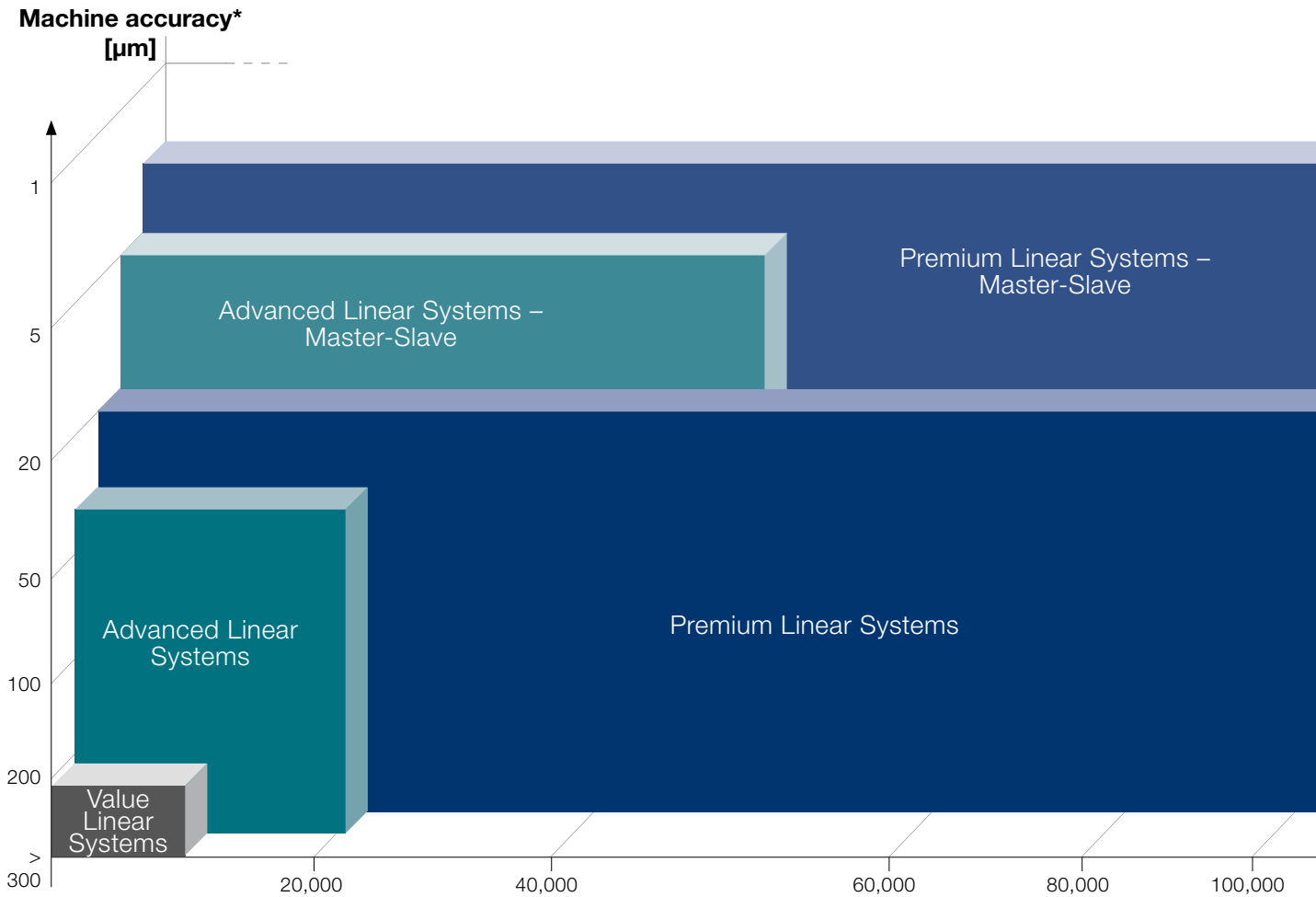

Preferred linear systems for all requirements

We have assembled the perfect combination of gearbox, pinion and rack for each segment. This is how you find the best suited preferred linear system for your requirements in the Value, Advanced and Premium Segments.

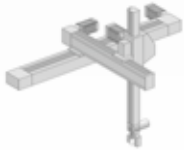

The performance spectrum of our preferred linear systems of the Value, Advanced and Premium Segments.

The wide application range of our linear systems

| Value Linear Systems | | | Advanced Linear Systems | |
|---|---|---|---|---|
|  |  |  |  |  |
| Pick and place robot | Welding robot | 7th Axis | Plasma cutting system | Wood working |

Here you can find the correct preferred linear systems in the Value (VLS), Advanced (ALS) and Premium (PLS) Segments.

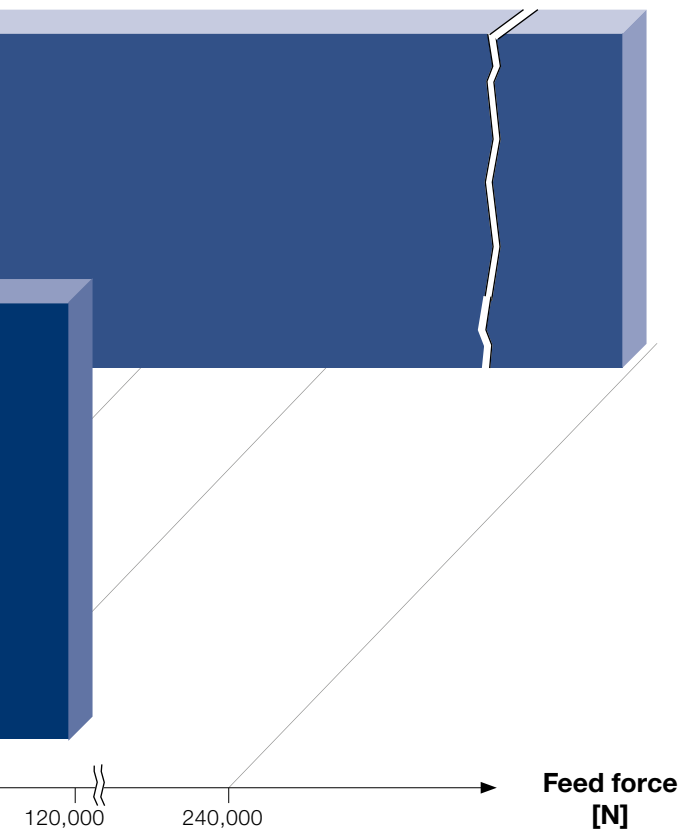

| Value Linear System | | Advanced Linear System | | | | Premium Linear System | | |
|---------------------|------|------------------------|------|----------------------|------|-----------------------|----------------------|------|
| with NPR | Page | with SP ⁺ | Page | with TP ⁺ | Page | with XP ⁺ | with RP ⁺ | Page |
| | | | | ALS 1 | 62 | | | |
| VLS 2 | 36 | ALS 2 | 52 | ALS 2 | 64 | | | |
| VLS 3 | 38 | ALS 3 | 54 | ALS 3 | 66 | | | |
| VLS 4 | 40 | | | | | | | |
| | | | | | | PLS 5 | | 84 |
| VLS 6 | 42 | ALS 6 | 56 | | | | | |
| VLS 8 | 44 | ALS 8 | 58 | | | PLS 8 | | 86 |
| | | | | | | PLS 10 | | 90 |
| | | | | | | PLS 11 | | 88 |
| | | ALS 12 | 60 | ALS 12 | 68 | | | |
| | | | | | | | | |
| | | | | ALS 20 | 70 | | | |
| | | | | ALS 21 | 76 | | | |
| | | | | | | | | |
| | | | | | | PLS 13 | | 92 |
| | | | | | | PLS 20 | | 94 |
| | | | | | | | | |
| | | | | | | PLS 22 | | 96 |
| | | | | | | PLS 36 | | 98 |
| | | | | | | PLS 47 | | 100 |
| | | | | | | PLS 75 | | 102 |
| | | | | | | PLS 112 | | 104 |

VLS / ALS / PLS = system designation
 1 - 112 = maximum feed force in kN

* depending on other parameters

Premium Linear Systems

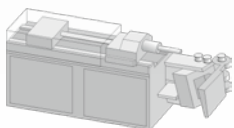

Pipe bending machine

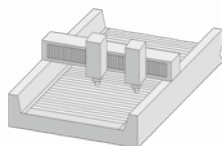

Flatbed laser

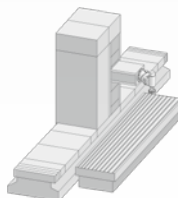

Travelling column milling machine

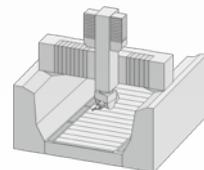

Portal milling machine

The R-flange sets the standard

The R-flange has become indispensable in rack and pinion drive trains: It is the benchmark for modularity and ease of installation – together with a host of design options.

A wide range of convincing benefits:

Design benefits:

- Reduced number of components and therefore lower design and materials management costs.
- Greater design flexibility because the centering length of the gearbox is not reduced by additional adjustment plates or other solutions.
- Realization of significantly more rigid connecting structures.
- Rectangular gearbox flange for simple centering of the gearbox.
- A bolt connection adapted to the drive train eliminates the need for additional calculations of the connection geometry.

Assembly / production benefits:

- Slots integrated in the gearbox flange make it easy to position the gearbox with a mounted pinion in relation to the rack. During the adjustment process, the gearbox is guided by the guide surface on the gearbox flange.
- A milled guide surface on the machine slide is sufficient here.
- Less mounting effort due to a significant reduction in the number of fastening screws. Additional threaded holes in the gearbox flange allow for simple handling.

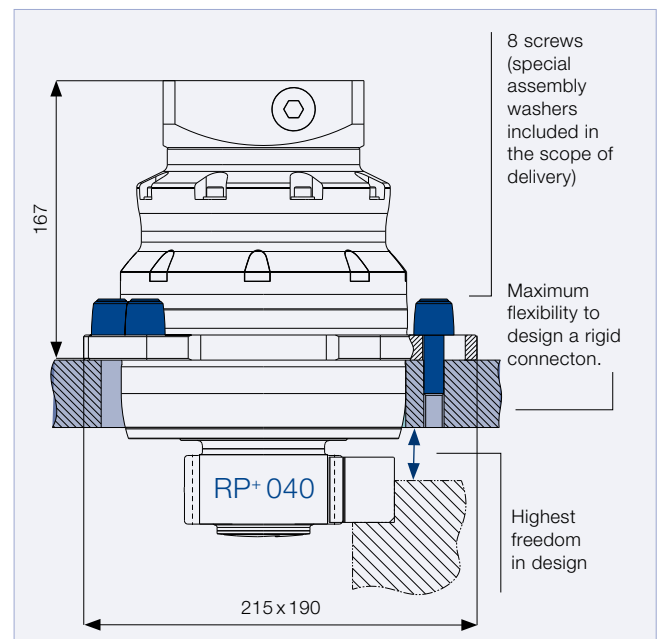
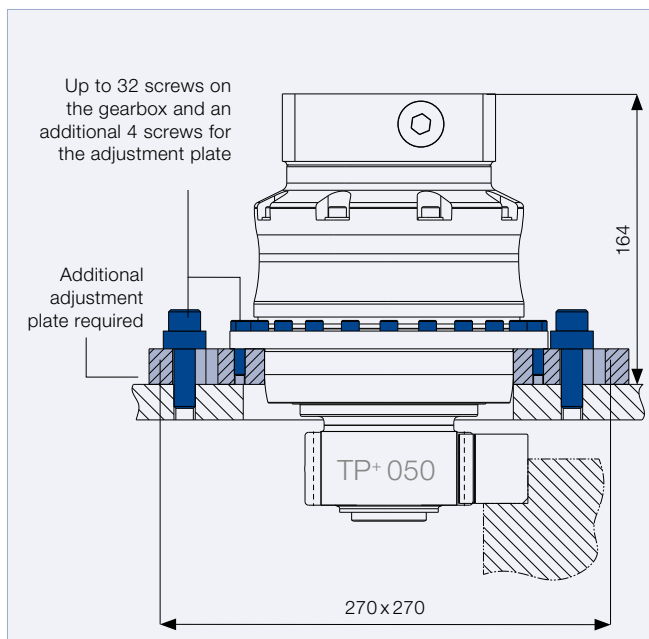

The RP+ generates more than twice the feed force of the TP+ 050 (industry standard) at the same space requirements.

A wide variety of variants and applications

The R-flange is available for gearboxes from the RP series as well as the following gearboxes:

- NPR
- SP⁺ R
- XP⁺ R; XPC⁺ R; XPK⁺ R, PHG
- RP⁺; RPC⁺; RPK⁺; RPM⁺

The highlights

- The high-performance planetary gearboxes are setting new standards in terms of power density, rigidity, transmittable torques and ease of installation.
- In the servo actuator version RPM⁺, the permanently actuated servo motor with extremely compact special design ensures maximum power density and dynamics.
- Right-angle gearboxes RPC⁺, RPK⁺, XPC⁺ R and XPK⁺ R are the perfect solution to limited installation space. Different ratios allow for a precise adaptation to the particular application.
- The RP⁺ and XP⁺ families are optimized for our RMW pinions.
- On request, RP⁺ variants are also available with threaded holes in the output flange for your individual solution.



NPR



SP⁺ R



XPC⁺ R



RPM⁺

You have the choice

Our preferred linear systems already offer the ideal pre-selection of pinions in terms of smooth running, positioning accuracy and feed force – matched with the gearbox and rack. WITTENSTEIN alpha offers an additional wide selection of different variants. In case your requirements extend beyond the capabilities offered by the preferred linear system, cymex® 5 gives you the option of selecting the perfect pinion from a comprehensive database. Starting with your application, you can configure an individual linear system and optimize the feed speed, feed force and rigidity. Our sales engineers and application consultants would be happy to help you design your system.

All of our pinions are supplied factory assembled – offering you the following benefits:

- Tested quality by 100 % final inspection
- Maximum quality and reliability
- Perfect calibration of the tooth backlash between pinion and rack due to aligned pinion and marked high point
- Prevention of potential sources of error and reduced assembly effort

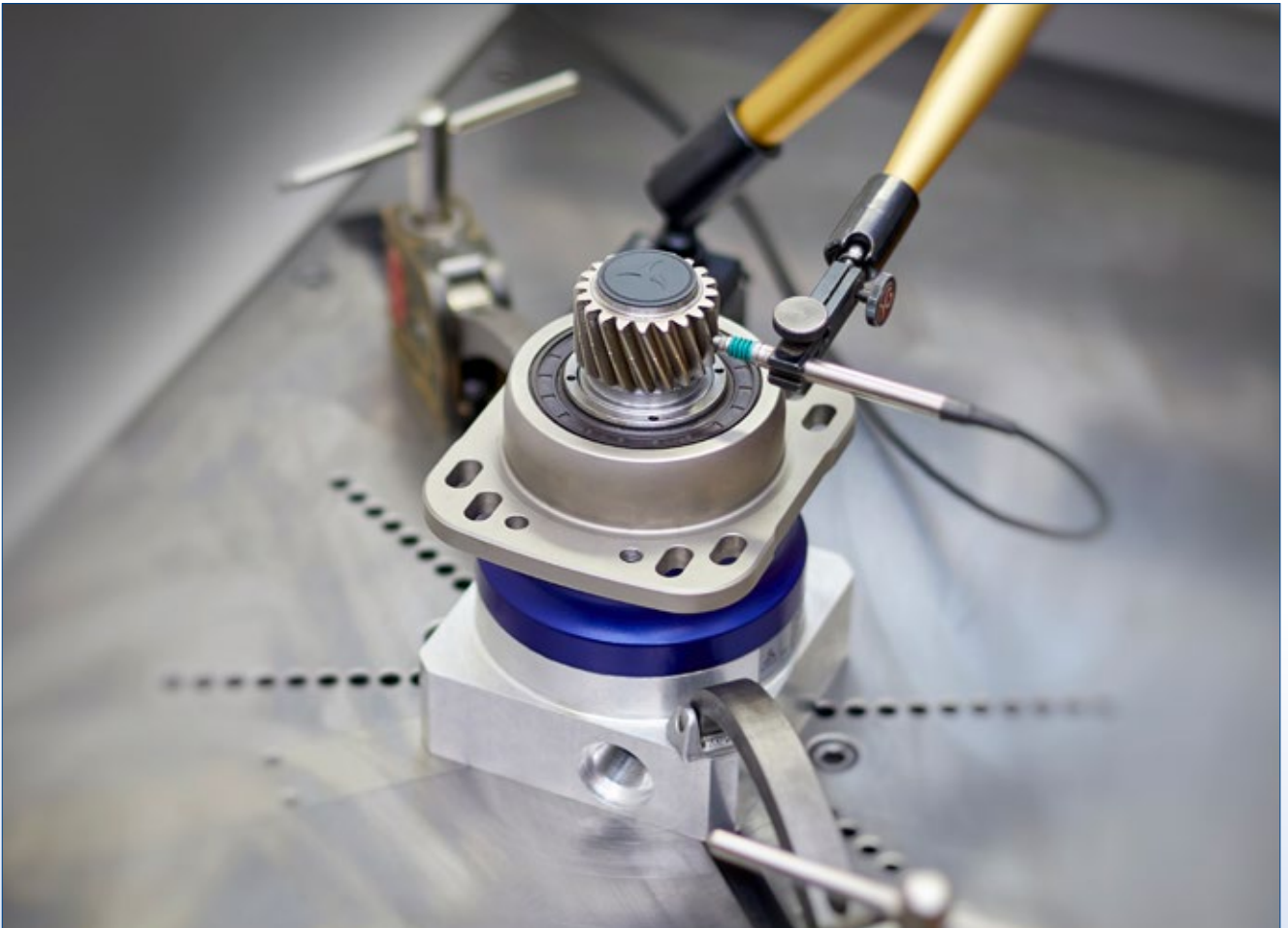

Overview of pinion variants

RMK – pinion mounted on keyed shaft

- Precise tothing with optimally designed tothing geometry
- Backlash-free shrink-fit/bonded connection with parallel key as overload protection ensures perfect seating of the pinion throughout the entire service life
- Application-specific variants available



RMS – pinion mounted on splined shaft (DIN 5480)

- Precise tothing with optimally designed tothing geometry
- Form fit connection between pinion and gearbox output shaft
- Compact design
- With marked high point
- Application-specific variants available



RMF – pinion mounted on flange

- High-precision and optimally designed tothing geometry for superior smooth running, high positioning accuracy and outstanding power transmission in the application
- Adapted to the standard gearbox series with the proven TP+ flange
- High feed speeds with low input speeds thanks to large pitch diameter
- Compact pinion/gearbox connection
- With marked high point
- Application-specific variants available



RMW – pinion mounted on system output

- Perfectly designed high-precision tothing geometry for maximum smooth running, high positioning accuracy and highest feed forces in the application
- Innovative pinion/gearbox connection ensures:
 - Highest linear rigidity through the direct connection of pinions with small pitch circle diameter
 - Maximum flexibility in pinion selection
 - Compact drive design
- With marked high point
- Application-specific variants available



INIRA®: The revolution in rack assembly

INIRA® combines our existing innovative concepts for the simple, safe and efficient installation of racks. INIRA® clamping, INIRA® adjusting and INIRA® pinning have already made the assembly process much faster, more accurate and more ergonomic. Available for the Advanced and Premium Linear Systems.



Simply scan the QR code using your smartphone to experience INIRA® in action.
www.wittenstein-alpha.com/INIRA

INIRA® clamping: Simply faster and more ergonomic

Previously, enormous effort was required to clamp racks to the machine bed using screw clamps. INIRA® clamping integrates the clamping device into the rack. The clamping is achieved quickly and ergonomically by the use of a mounting sleeve which is guided by the head of the fastening screw.

INIRA® pinning: Simply better and more efficient

The previous method used for pinning racks was extremely time-consuming. Precise bores had to be drilled and the generated chips carefully removed from the assembly. INIRA® pinning now offers a completely new solution for the chipless pinning of racks, which reduces installation times considerably (time spent on each rack ~ 1 min).

INIRA® adjusting: Simply safer and more precise

In combination with INIRA® clamping, INIRA® adjusting is the ideal solution for perfect adjustment of the transition between two rack segments. With the innovative adjustment tool, the transition can be adjusted safely and accurately, precise to the micron.

See page 150 for more information about racks.



INIRA® clamping



INIRA® adjusting



INIRA® pinning

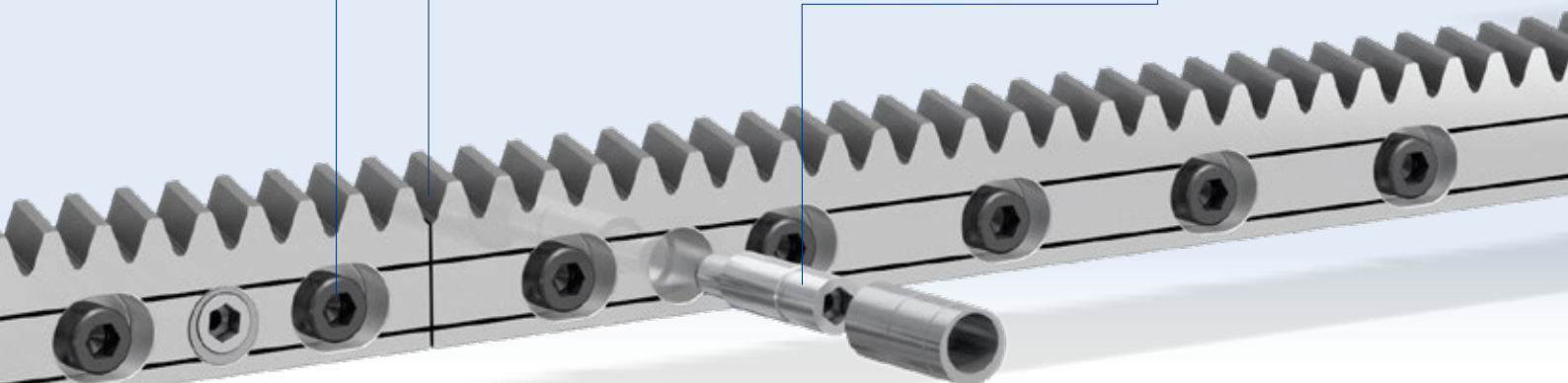

We have the suitable rack for every requirement – in all quality categories

Needless to say, finding the appropriate rack is an essential component in realizing your machine concepts. You are guaranteed to find the perfect rack in our portfolio. You can select the ideal rack for your application, depending on your demands in terms of smooth running, positioning accuracy, feed force and ease of installation.

Besides our INIRA® racks, there are standard racks for the Advanced Linear Systems and Premium Linear Systems available.

Our preferred linear systems of the Value, Advanced und Premium Line already contain a preselection of components whose parameters have been perfectly adapted to the respective system. In order to meet your rack requirements, we employ flexibly adapted production processes. It goes without saying that racks for High Performance applications are case-hardened to meet demanding feed force requirements and guarantee maximum system performance throughout the entire service life of the rack.

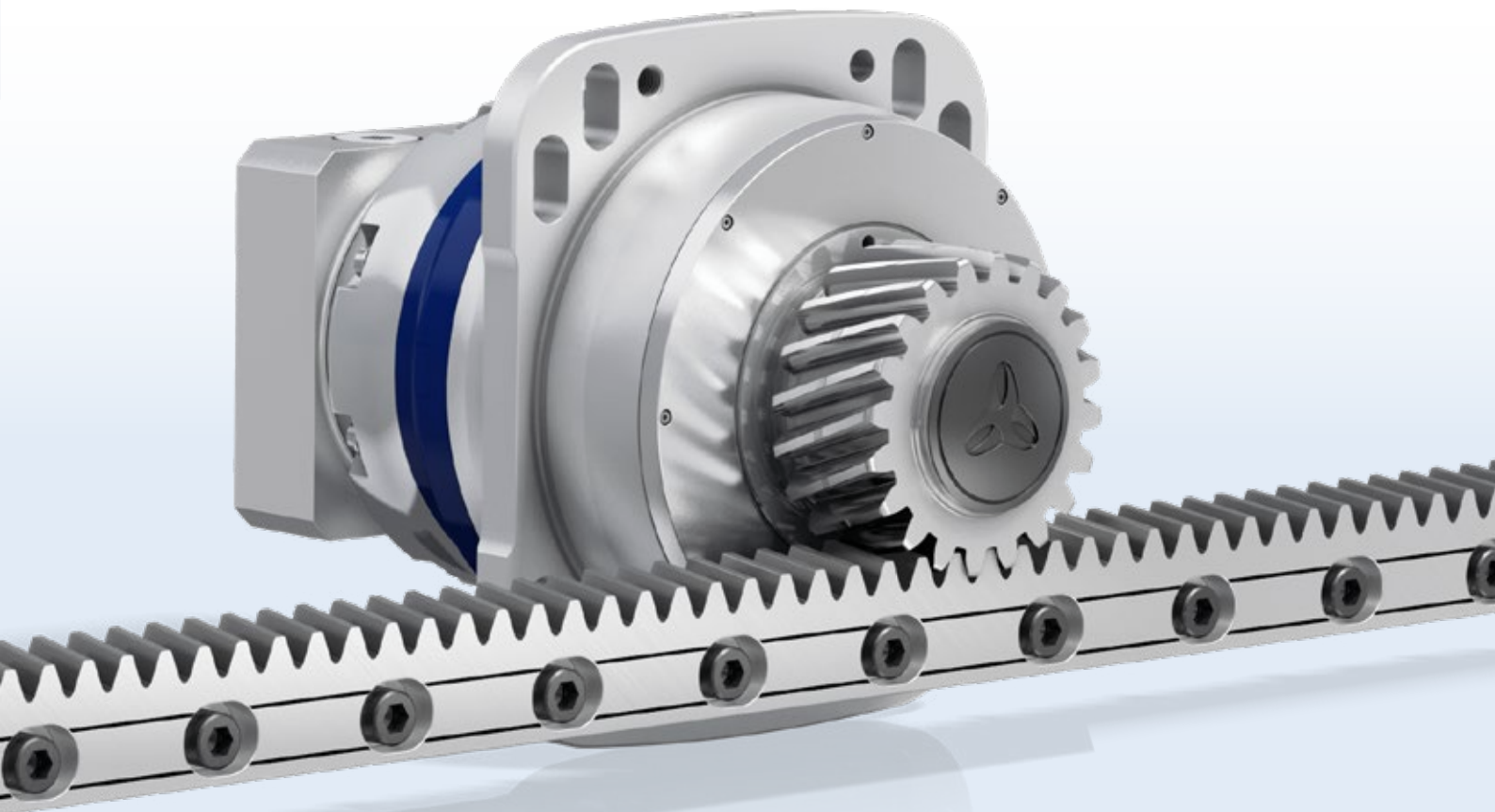
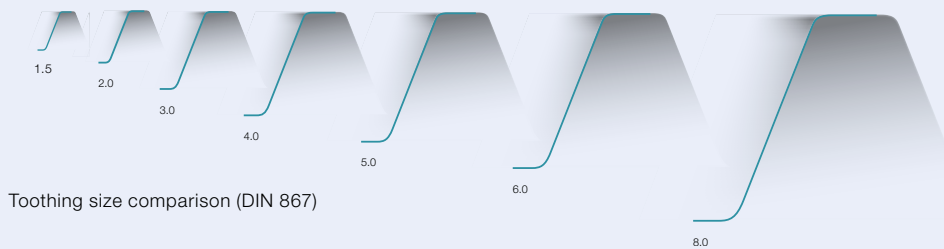

cymex[®] 5 is the current standard

With cymex[®] 5, the dimensioning and design of complete drive trains (application + transformation + gearbox + motor) is now fast, simple and reliable. Calculation is made much easier through predefined standard applications. Consideration for all major influencing factors guarantees an optimal design and increases the efficiency of your machine.

cymex[®] 5 can define any number of axes simultaneously

In contrast to other design tools, cymex[®] 5 can define any number of axes at the same time. The version calculation is up to 60% quicker as a result.

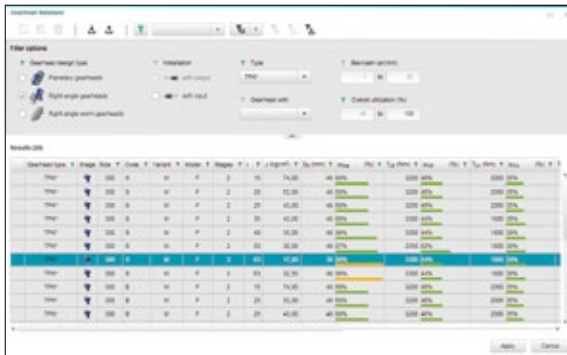

cymex[®] 5 has an extremely extensive database

More than 14,000 motors from the 50 most prominent motor manufacturers are stored in the design tool. Continuously updated, always state-of-the-art. Moreover, more than 8,000 gearbox versions from WITTENSTEIN alpha and over 200 combinations of linear systems with all relevant technical specifications can be found here.

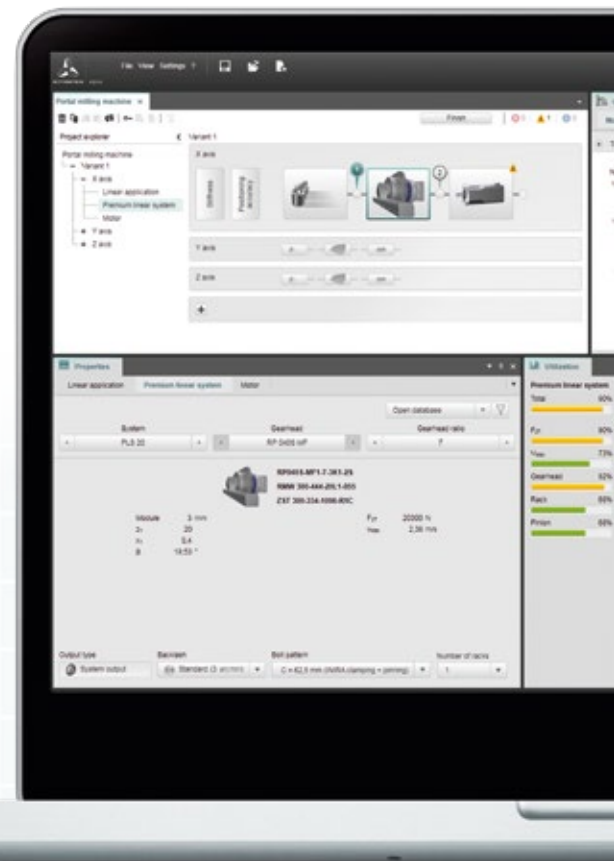

Free download

The basic version of cymex[®] 5 design software is available as a free download.



www.wittenstein-cymex.com

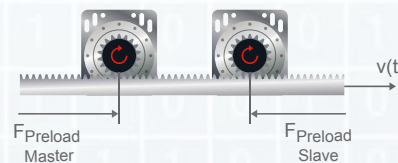

cymex[®] 5 incorporates the completely new Master / Slave function*

The Master / Slave function enables the electrically clamped configuration of two drives. The mutual tensioning of master and slave eliminates the backlash in the drive train and provides for a high degree of rigidity in the machine.

*Premium function, on request.

cymex® 5



thumbs up cymex® 5 has a unique optimization calculator*

During the design process, cymex® 5 provides optimization suggestions for the selected gearbox, which increase reliability and efficiency while ensuring your gearbox has the perfect dimensions e.g. through downsizing. This saves on costs and reduces the installation space in the machine.

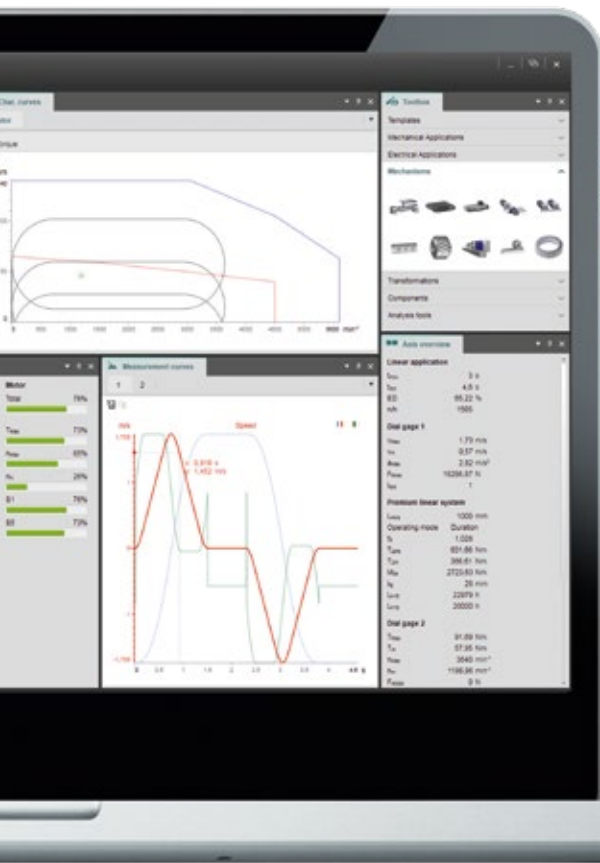

thumbs up cymex® 5 offers comprehensive documentation

Following the geometry comparison, cymex® 5 creates calculation documentation and generates data sheets for gearbox and motor on request. Furthermore, the 2D and 3D CAD data of selected components can be retrieved.



Preferred linear systems



11 languages

thumbs up cymex® 5 allows quick selection of the appropriate linear system

cymex® 5 allows you to select the most suitable system quickly and easily based on your personal linear drive train requirements. Predefined preferred linear systems have already been optimized in terms of the feed force, feed speed, rigidity and degree of utilization of the individual components, and can be adapted according to individual requirements if needed (e.g. gearbox model, number of teeth on the pinion, rack execution).

Support at each interaction stage

With the WITTENSTEIN alpha service concept, we are also setting new standards in the field of customer support.

DESIGN



We offer the right sizing methodology for every requirement. Whether easy downloading of CAD data, quick and easy calculation, or precise sizing of the drive train.

STARTUP



Our service experts are happy to support you in the installation and startup of complex mechatronic systems, guaranteeing maximum availability of your plant.

SERVICING



WITTENSTEIN alpha guarantees fast repairs of the highest quality and precision. In addition, we will provide you with information about various measurements, material analyses, and condition monitoring inspections.

Consultation

- Personal contact on site
- Competent application calculations and drive sizing

Engineering

Catalog gearboxes:

- Advanced software tools for accurate calculation, simulation, and analysis of the drive train
- Optimization of your productivity

Special gearboxes:

- Development and production of customized gearboxes
- Gearing design and development
- Inquiries: sondergetriebe@wittenstein.de



CAD POINT
YOUR SMART CATALOG



SIZING ASSISTANT
YOUR GEARBOX WITHIN SECONDS



cymex® 5
CALCULATE ON THE BEST

speedline® delivery

Tel. +49 7931 493-10444

- Delivery of standard product range in 24 or 48 hours ex works*
- Fast deliveries at short notice

Installation on site

- Professional installation
- Optimal application integration
- Introduction to the operation of the drive

Operating and installation instructions

- Detail description of how to use the product
- Installation and motor mounting videos

Pick-up & return service

- Minimization of downtimes
- Professional logistics organization
- Reduction of transport risks

* Non-binding delivery time depending on part availability

24 h service hotline

Tel. +49 7931 493-12900

Maintenance and inspection

- Documentation regarding condition and expected service life
- Customer-specific maintenance schedules

Repairs

- Repair to nominal condition
- Immediate response in time-critical situations

cymex® statistics

- Systematic field data acquisition
- Reliability calculations (MTBF)

Modernization

- Professional retrofitting
- Reliable compatibility testing of existing solutions

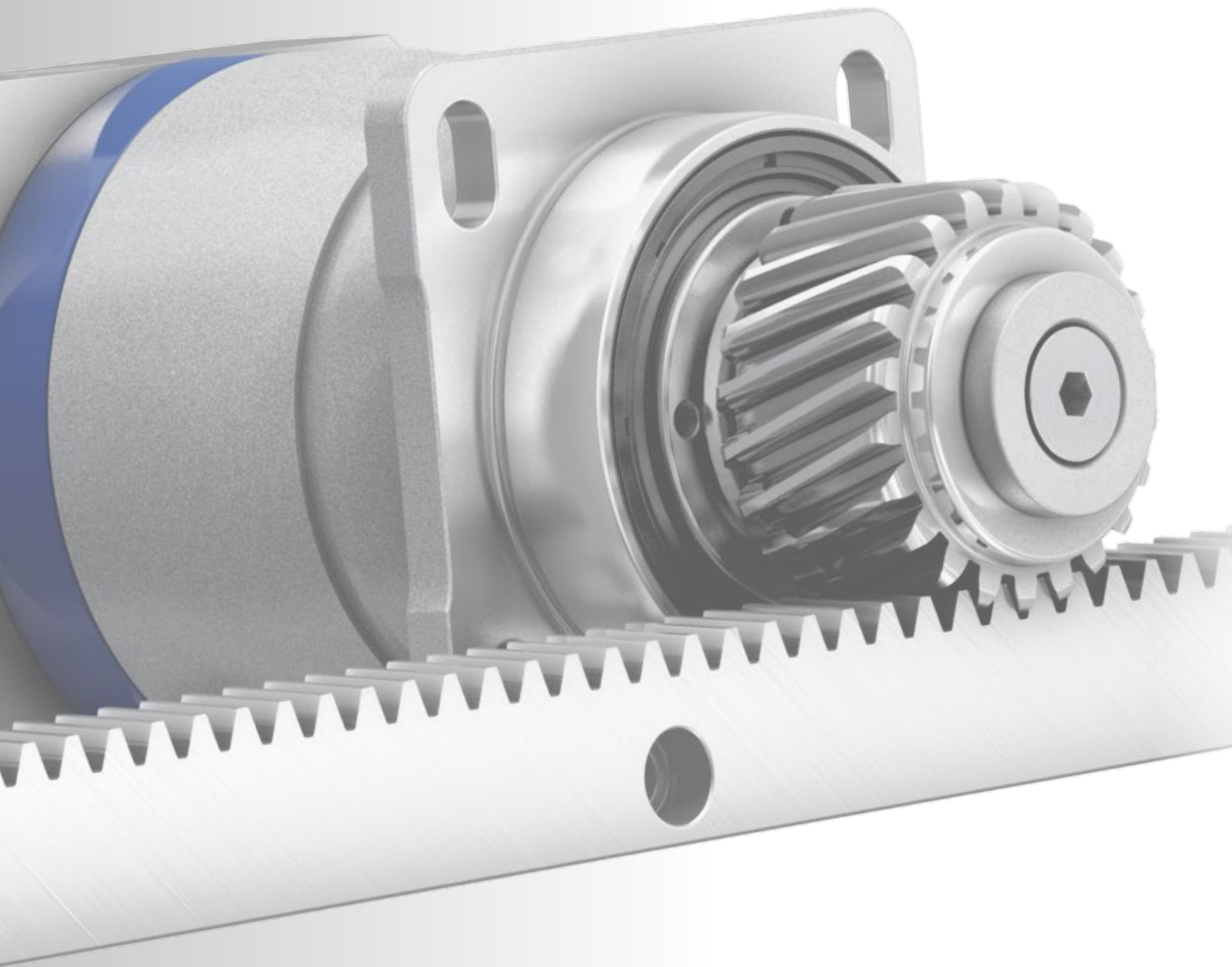

Value Linear Systems from WITTENSTEIN alpha –
flexible all-rounders in the Value Segment

The Value Linear System with **NPR** for use e.g. in plasma cutting systems, water jet cutting systems, simple laser cutting machines or even pipe bending machines with up to 8,000 N/drive train.

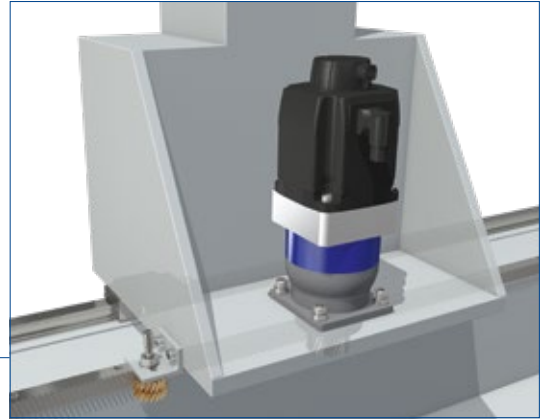
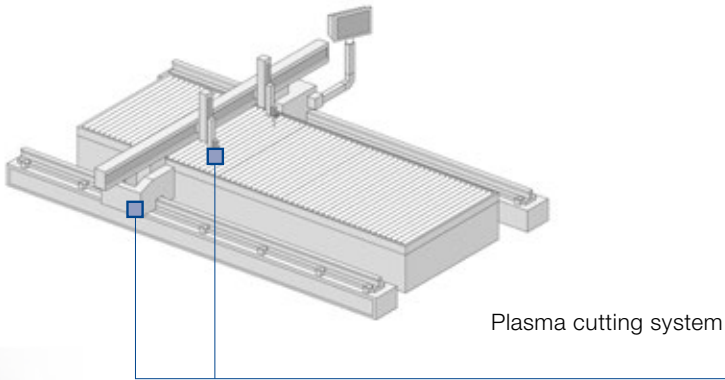

The Value Linear System with **NPR** and **NVS** are used in automation portals, welding robots, pick and place robots, 7th axis, etc.

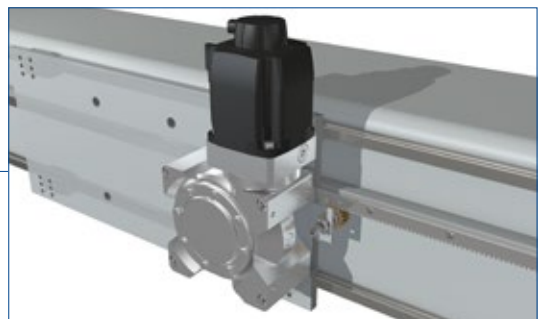
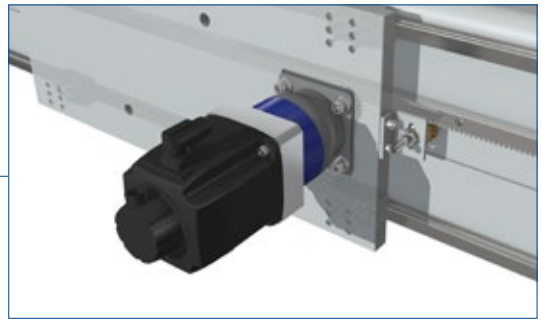
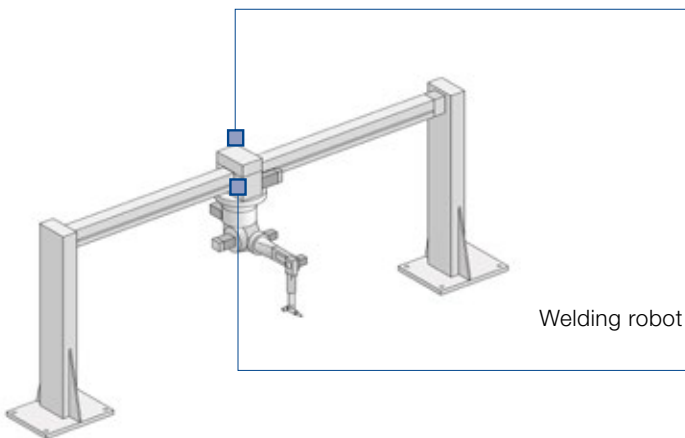

The flexible all-rounder in the Value Segment

The Value Linear System is adapted to linear applications in the Value Segment with comparatively low requirements in terms of smooth running, positioning accuracy and feed force. The R-flange of the Premium Segment now allows greater design freedom in the Value Segment.

Your benefits in detail

- **Integrated R-flange for simple design and assembly**
- **Perfectly adapted to the Value Line systems**
- **Available with NVS worm gear**

| | Value Linear System | Max. feed force [N] | Max. feed speed [m/min] |
|----------|---------------------|---------------------|-------------------------|
| with NPR | VLS 2 | 1890 | 253 |
| | VLS 3 | 3400 | 342 |
| | VLS 4 | 4300 | 347 |
| | VLS 6 | 6150 | 400 |
| | VLS 8 | 8000 | 160 |

Feed force and feed speed dependent on ratio



NPR

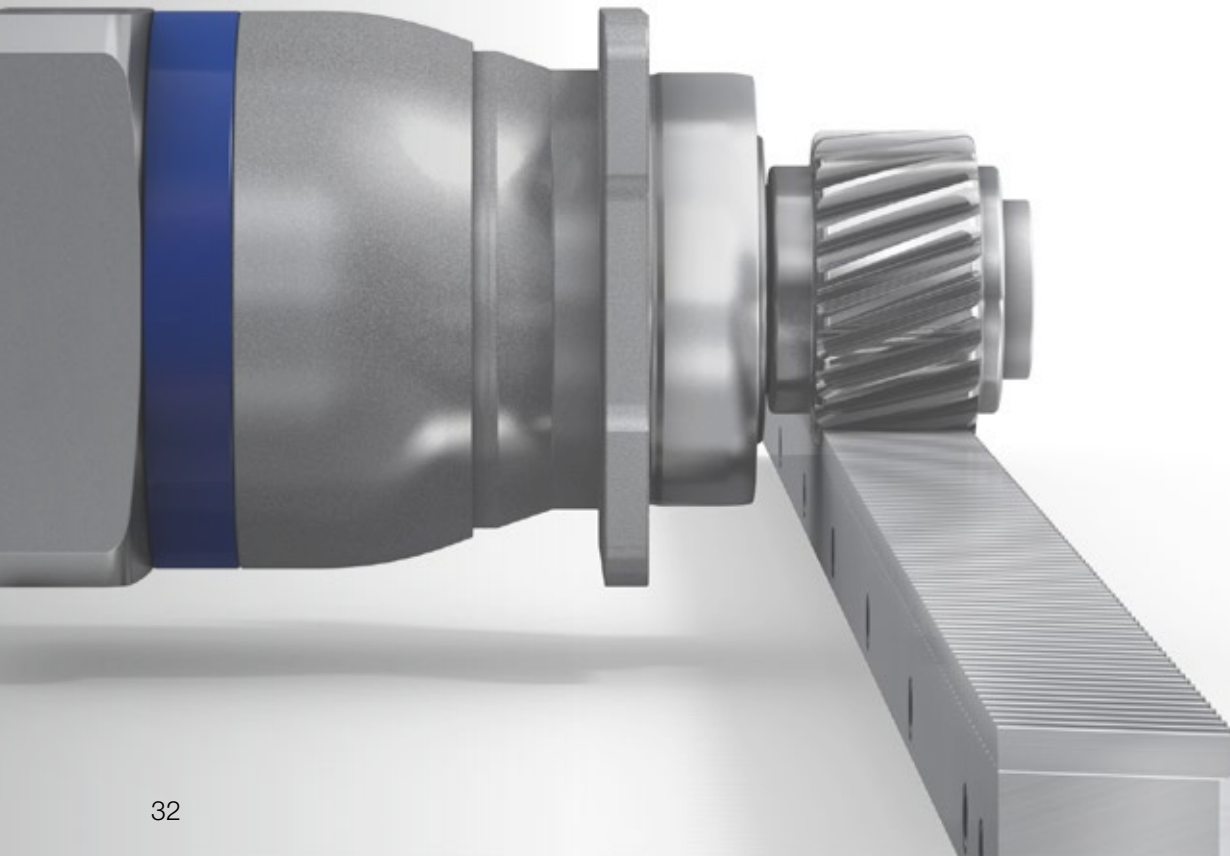

Quick system selection

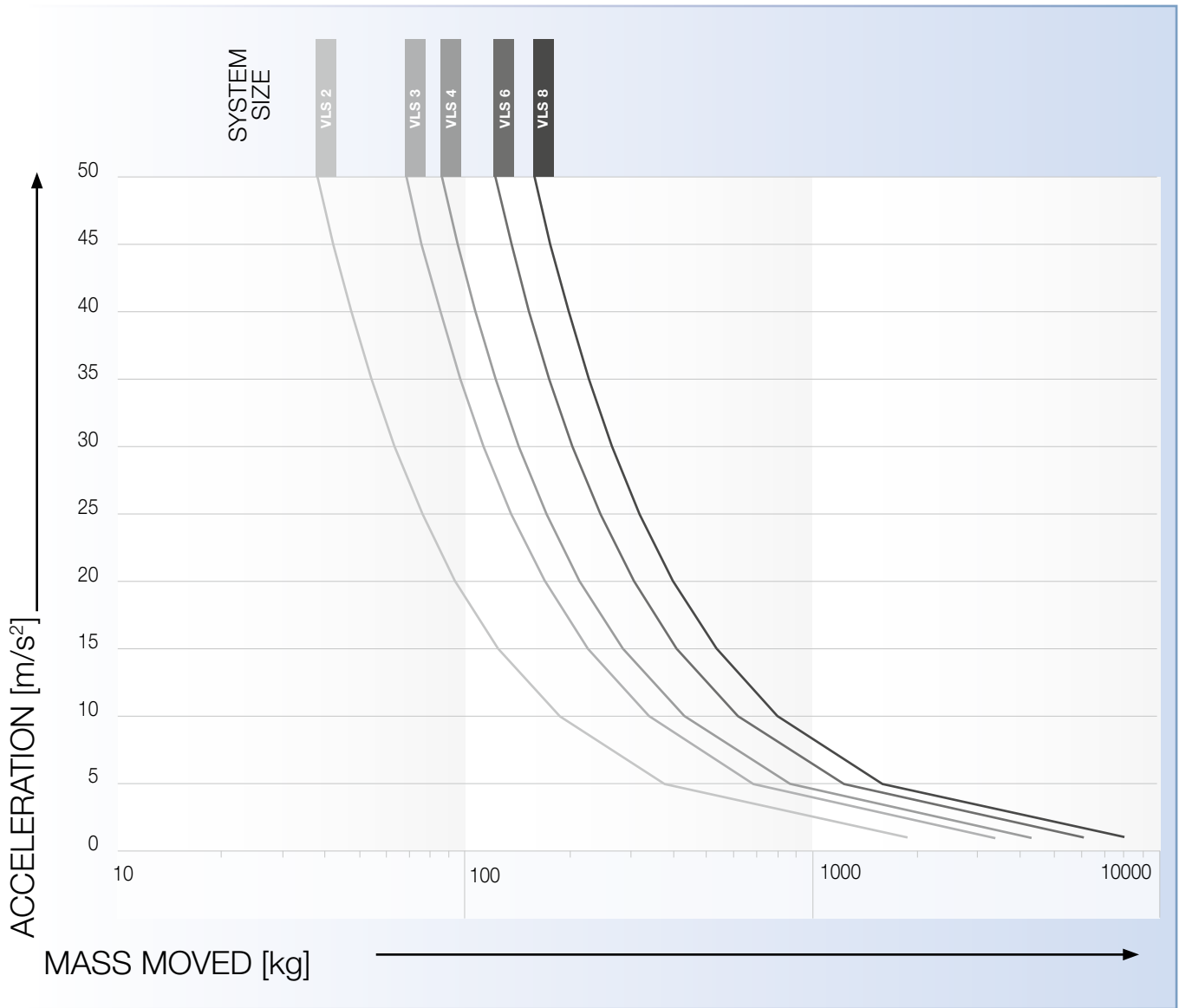

Value Linear Systems overview

Our preferred linear systems are always comprised of the perfect combination of gearbox, pinion, rack and lubrication system. The systems are optimized to achieve the required feed force, feed speed, rigidity and degree of utilization of the individual components. Depending on your individual requirements, you have the option to further configure products via the ordering code. For a detailed dimensioning and configuration of the products we recommend to use cymex® 5.

| System | Gearbox | Pinion | Rack |
|--------|----------|----------------------|---------------------|
| VLS 2 | NPR 015S | RMK 150-222-19L1-016 | ZST 150-222-1000-R1 |
| VLS 3 | NPR 025S | RMK 200-222-22L1-022 | ZST 200-222-1000-R1 |
| VLS 4 | NPR 035S | RMK 200-222-26L1-032 | ZST 200-222-1000-R1 |
| VLS 6 | NPR 035S | RMS 300-323-20L1-032 | ZST 300-222-1000-R1 |
| VLS 8 | NPR 045S | RMS 300-323-20L1-040 | ZST 300-222-1000-R1 |



Assembly accessories can be found starting at page 128 and information on the lubrication system starting at page 116

Ordering code

Gearbox*

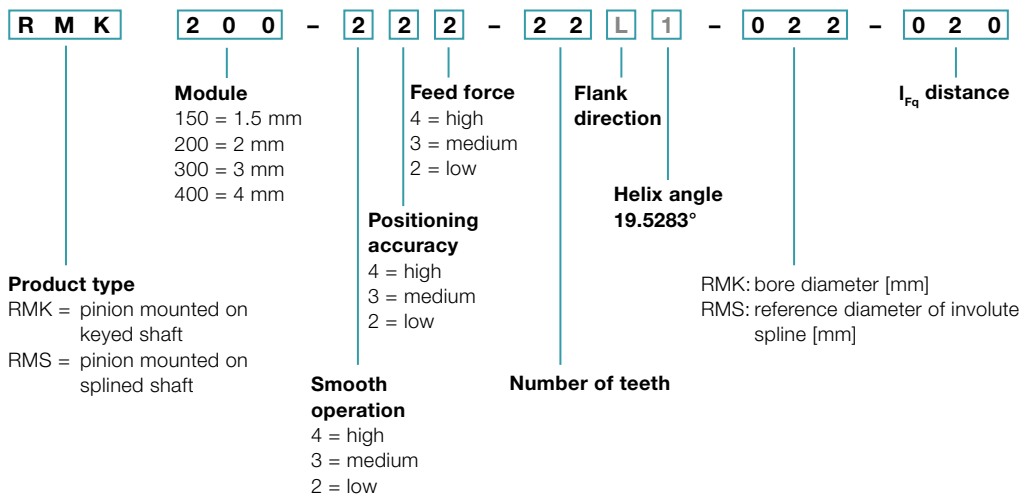
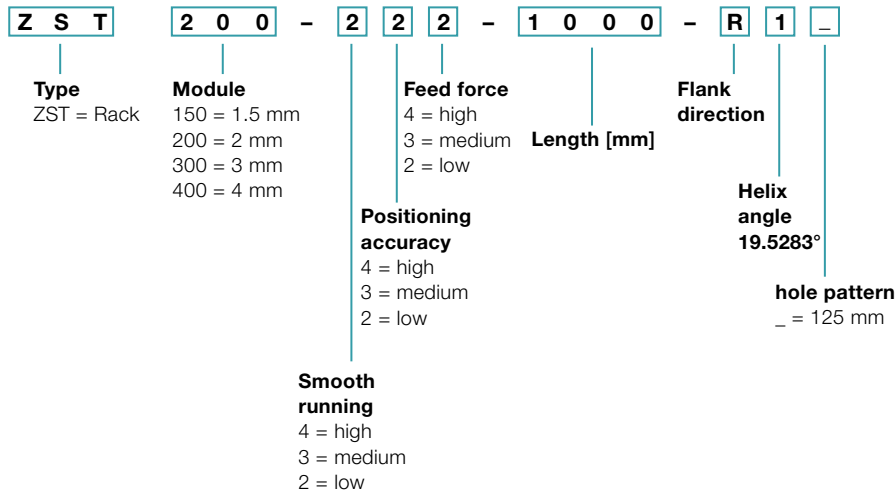
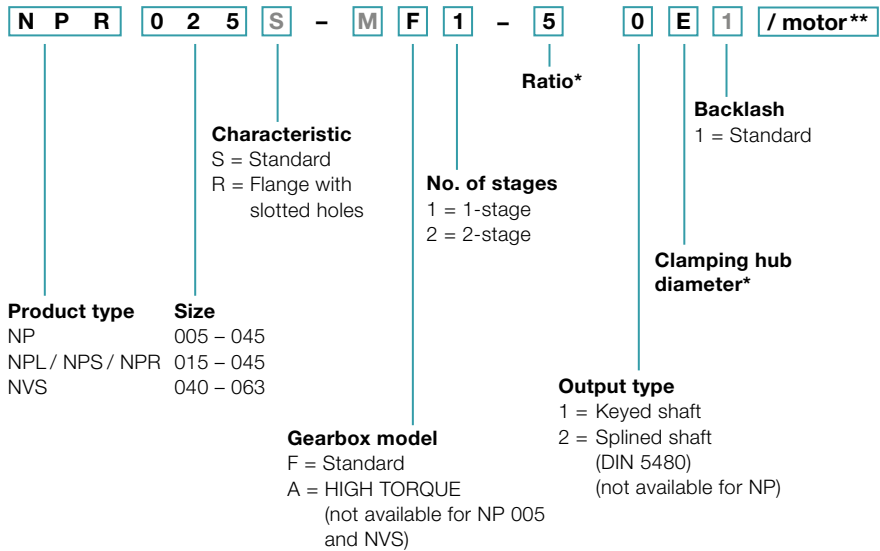

M Components with a gray font cannot be selected

* Further information about the gearboxes is available in the respective catalogs, at www.wittenstein-alpha.com or on request

** Full motor designation only required to determine gearbox mounting parts

Value Linear System VLS 2 with NPR

Planetary gearbox NPR 015 MF with rack module 1.5 and pinion RMK module 1.5

| | | | | |
|---|---|---------------------|--------------------------|--|
| System | Max. feed force ¹⁾ F_{2T} | | 1890 N | |
| | Max. feed speed ²⁾ v_{max} | | 253 m/min | 79 m/min |
| Gearbox | No. of stages | | 1 | 2 |
| | Ratios i | | 3 / 4 / 5 / 7 / 8 / 10 | 12 / 15 / 16 / 20 / 25 / 28 / 30 / 32 / 35 / 40 / 50 / 64 / 70 / 100 |
| | Clamping hub diameter | | 9 / 11 / 14 / 16 / 19 mm | 8 / 9 / 11 / 14 mm |
| | Designation | | NPR 015S-MF1-_-_-1_-_- | NPR 015S-MF2-_-_-1_-_- |
| Pinion | Module m | | 1.5 mm | |
| | Number of teeth z | | 19 | |
| | Pitch circle diameter d | | 30.239 mm | |
| | Profile correction factor x | | 0.3 | |
| | Helix angle β | | -19.5283° (left-handed) | |
| | Designation | | RMK 150-222-19L1-016-022 | |
| Rack | Module m | | 1.5 mm | |
| | Lengths L | | 1000 mm | |
| | Helix angle β | | 19.5283° (right-handed) | |
| | Designation | | ZST 150-222-1000-R1 | |
| Lubrication system ³⁾ | Set consisting of lubrication pinion and axis for | Rack | LMT 150-PU -24L1-020-1 | |
| | | Pinion | LMT 150-PU -24R1-020-1 | |
| | Lubricator | 125 cm ³ | LUC+125-0511-02 | |
| | | 400 cm ³ | LUC+400-0511-02 | |
| | Lubricant | | WITTENSTEIN alpha G11 | |

¹⁾ Maximum feed force depending on ratio and number of stages

²⁾ Calculation with lowest ratio and maximum input speed

³⁾ Impulse-controlled basic version with one output and 2 m hose. See page 116 for further information on the lubrication system.

Application-specific dimensioning with cymex® – www.wittenstein-cymex.com

Alternative system solutions

| Pinion | | | Axis distance | NPS/ NPL/ NPR 015S | NVS 040 | Rack |
|--------------------------|-------------|------------|---------------|--------------------|-----------------|---------------------|
| Designation | d [mm] | x [] | A [mm] | F_{2T} [N] | F_{2T} [N] | Designation |
| RMK 150-222-19L1-016-022 | 30.239 | 0.3 | 33.070 | 1890 | 1890 | ZST 150-222-1000-R1 |
| RMK 200-222-18L1-016-019 | 38.197 | 0.4 | 41.899 | 2080 | 2220 | ZST 200-222-1000-R1 |
| RMS 200-323-15L1-016 | 31.831 | 0.5 | 38.916 | 2420 | – | ZST 200-222-1000-R1 |
| RMS 200-323-16L1-016 | 33.953 | 0.5 | 39.977 | 2350 | – | ZST 200-222-1000-R1 |
| RMS 200-323-18L1-016 | 38.197 | 0.4 | 41.899 | 2080 | – | ZST 200-222-1000-R1 |

d = Pitch circle diameter

x = Addendum modification coefficient

A = Distance between pinion axle and rear surface of rack

F_{2T} = Maximum feed force depending on ratio and number of stages

Application-specific dimensioning with cymex® – www.wittenstein-cymex.com

1-stage

up to 14⁴⁾ (C)
clamping hub
diameters

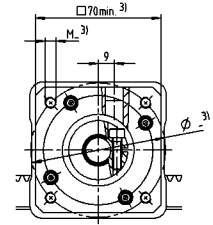
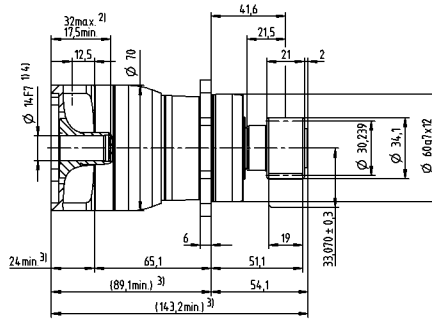
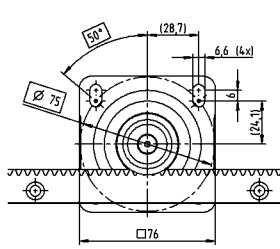

up to 19⁴⁾ (E)
clamping hub
diameters

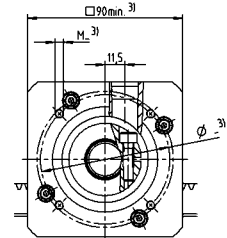
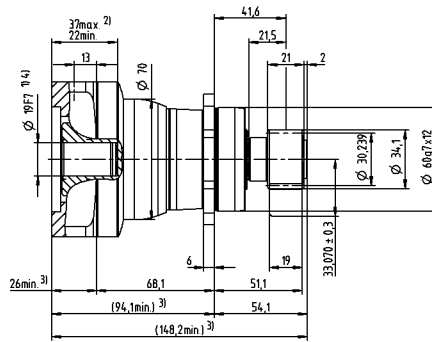
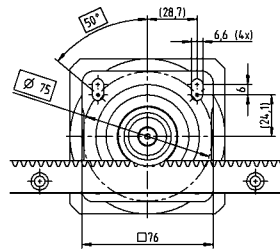

2-stage

up to 11⁴⁾ (B)
clamping hub
diameters

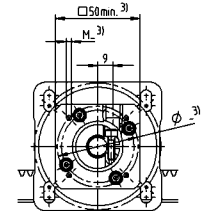
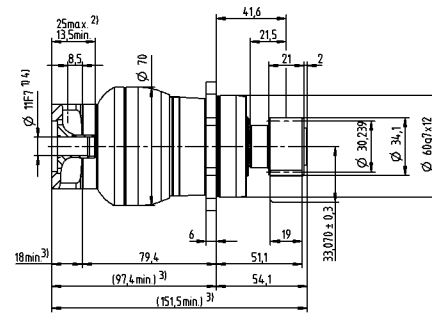
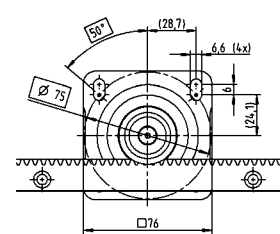

up to 14⁴⁾ (C)
clamping hub
diameter

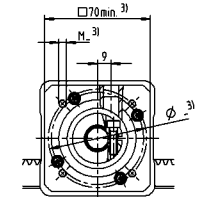
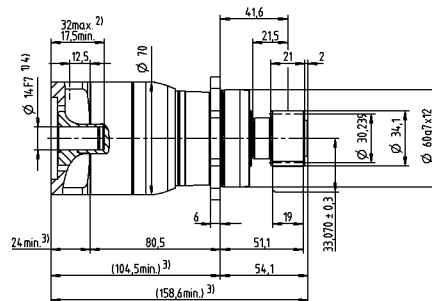
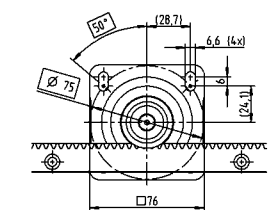

Motor shaft diameter [mm]

Non-tolerated dimensions are nominal dimensions
Detailed rack dimensions starting on page 151
1) Check motor shaft fit
2) Min./Max. permissible motor shaft length. Longer motor shafts are possible, please contact alpha.
3) The dimensions depend on the motor
4) Smaller motor shaft diameter is compensated by a bushing with a minimum thickness of 1 mm

Value Linear System VLS 3 with NPR

Planetary gearbox NPR 025 MF with rack module 2 and pinion RMK module 2

| | | | | |
|---|---|---------------------|---------------------------|--|
| System | Max. feed force ¹⁾ F_{2T} | | 3400 N | |
| | Max. feed speed ²⁾ v_{max} | | 342 m/min | 130 m/min |
| Gearbox | No. of stages | | 1 | 2 |
| | Ratios i | | 3 / 4 / 5 / 7 / 8 / 10 | 9 / 12 / 15 / 16 / 20 / 25 / 28 / 30 / 32 / 35 / 40 / 50 / 64 / 70 / 100 |
| | Clamping hub diameter | | 14 / 16 / 19 / 24 / 28 mm | 9 / 11 / 14 / 16 / 19 mm |
| | Designation | | NPR 025S-MF1-_-_-_-1_-_- | NPR 025S-MF2-_-_-_-1_-_- |
| Pinion | Module m | | 2 mm | |
| | Number of teeth z | | 22 | |
| | Pitch circle diameter d | | 46.686 mm | |
| | Profile correction factor x | | 0.2 | |
| | Helix angle β | | -19.5283° (left-handed) | |
| | Designation | | RMK 200-222-22L1-022-020 | |
| Rack | Module m | | 2 mm | |
| | Lengths L | | 1000 mm | |
| | Helix angle β | | 19.5283° (right-handed) | |
| | Designation | | ZST 200-222-1000-R1 | |
| Lubrication system ³⁾ | Set consisting of lubrication pinion and axis for | Rack | LMT 200-PU -18L1-024-1 | |
| | | Pinion | LMT 200-PU -18R1-024-1 | |
| | Lubricator | 125 cm ³ | LUC+125-0511-02 | |
| | | 400 cm ³ | LUC+400-0511-02 | |
| | Lubricant | | WITTENSTEIN alpha G11 | |

¹⁾ Maximum feed force depending on ratio and number of stages

²⁾ Calculation with lowest ratio and maximum input speed

³⁾ Impulse-controlled basic version with one output and 2 m hose. See page 116 for further information on the lubrication system.

Application-specific dimensioning with cymex® – www.wittenstein-cymex.com

Alternative system solutions

| Pinion | | | Axis distance | NPS/ NPL/ NPR 025S | NP 025S | NVS 050 | Rack |
|--------------------------|-------------|------------|---------------|--------------------|-----------------|-----------------|---------------------|
| Designation | d [mm] | x [] | A [mm] | F_{2T} [N] | F_{2T} [N] | F_{2T} [N] | Designation |
| RMK 200-222-22L1-022-020 | 46.686 | 0.2 | 45.743 | 3400 | 2020 | 3530 | ZST 200-222-1000-R1 |
| RMS 200-323-18L1-022 | 38.197 | 0.4 | 41.899 | 3430 | - | - | ZST 200-222-1000-R1 |
| RMS 200-323-20L1-022 | 42.441 | 0.4 | 44.021 | 3420 | - | - | ZST 200-222-1000-R1 |
| RMS 200-323-22L1-022 | 46.686 | 0.4 | 46.143 | 3400 | - | - | ZST 200-222-1000-R1 |

d = Pitch circle diameter

x = Addendum modification coefficient

A = Distance between pinion axle and rear surface of rack

F_{2T} = Maximum feed force depending on ratio and number of stages

Application-specific dimensioning with cymex® – www.wittenstein-cymex.com

1-stage

up to 19⁴⁾ (E)
clamping hub
diameters

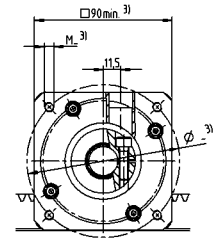
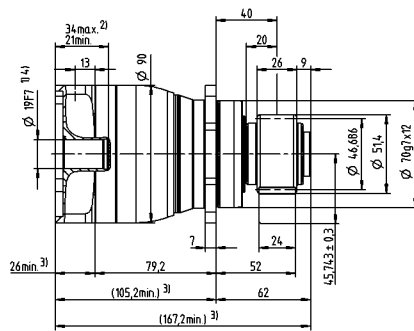
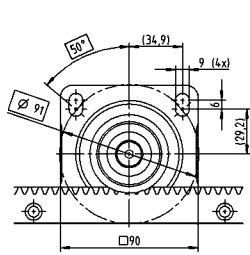

up to 28⁴⁾ (H)
clamping hub
diameters

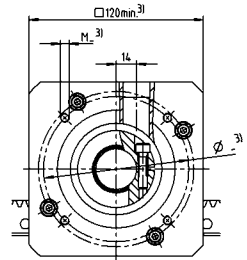
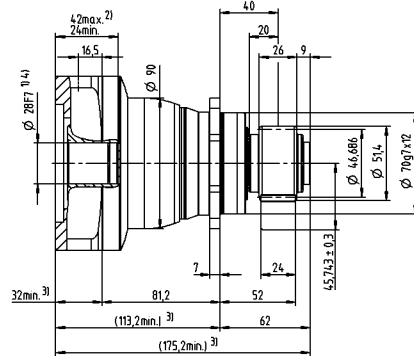
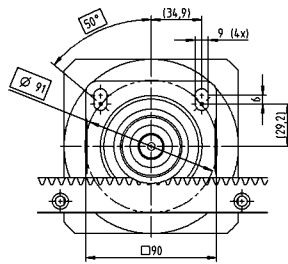

2-stage

up to 14⁴⁾ (C)
clamping hub
diameters

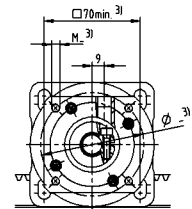
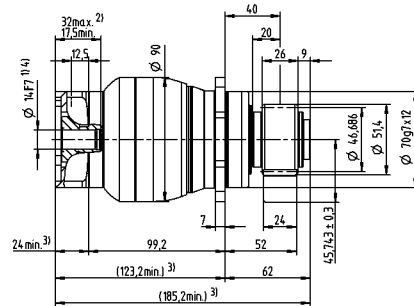
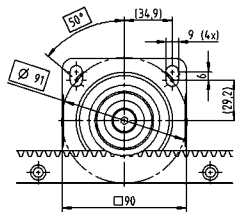

up to 19⁴⁾ (E)
clamping hub
diameters

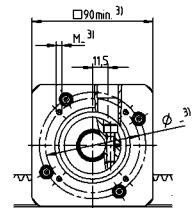
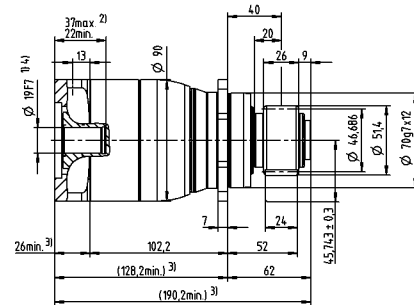
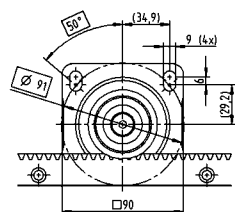

Motor shaft diameter [mm]

Non-tolerated dimensions are nominal dimensions
Detailed rack dimensions starting on page 151
1) Check motor shaft fit
2) Min./Max. permissible motor shaft length. Longer motor shafts are possible, please contact alpha.
3) The dimensions depend on the motor
4) Smaller motor shaft diameter is compensated by a bushing with a minimum thickness of 1 mm

Value Linear Systems

Value Linear System VLS 4 with NPR

Planetary gearbox NPR 035 MF with rack module 2 and pinion RMK module 2

| | | | | |
|---|---|---------------------|---------------------------|--|
| System | Max. feed force ¹⁾ F_{zT} | | 4300 N | |
| | Max. feed speed ²⁾ v_{max} | | 347 m/min | 135 m/min |
| Gearbox | No. of stages | | 1 | 2 |
| | Ratios i | | 3 / 4 / 5 / 7 / 8 / 10 | 9 / 12 / 15 / 16 / 20 / 25 / 28 / 30 / 32 / 35 / 40 / 50 / 64 / 70 / 100 |
| | Clamping hub diameter | | 19 / 24 / 28 / 32 / 38 mm | 14 / 16 / 19 / 24 / 28 mm |
| | Designation | | NPR 035S-MF1-_-_-_-1_-_- | NPR 035S-MF2-_-_-_-1_-_- |
| Pinion | Module m | | 2 mm | |
| | Number of teeth z | | 26 | |
| | Pitch circle diameter d | | 55.174 mm | |
| | Profile correction factor x | | 0 | |
| | Helix angle β | | -19.5283° (left-handed) | |
| | Designation | | RMK 200-222-26L1-032-021 | |
| Rack | Module m | | 2 mm | |
| | Lengths L | | 1000 mm | |
| | Helix angle β | | 19.5283° (right-handed) | |
| | Designation | | ZST 200-222-1000-R1 | |
| Lubrication system ³⁾ | Set consisting of lubrication pinion and axis for | Rack | LMT 200-PU -18L1-024-1 | |
| | | Pinion | LMT 200-PU -18R1-024-1 | |
| | Lubricator | 125 cm ³ | LUC+125-0511-02 | |
| | | 400 cm ³ | LUC+400-0511-02 | |
| | Lubricant | | WITTENSTEIN alpha G11 | |

¹⁾ Maximum feed force depending on ratio and number of stages

²⁾ Calculation with lowest ratio and maximum input speed

³⁾ Impulse-controlled basic version with one output and 2 m hose. See page 116 for further information on the lubrication system. Application-specific dimensioning with cymex® – www.wittenstein-cymex.com

Alternative system solutions

| Pinion | | | Axis distance | NPS/ NPL/ NPR 035S | NP 035S | NVS 063 | Rack |
|--------------------------|-------------|------------|---------------|--------------------|-----------------|-----------------|---------------------|
| Designation | d [mm] | x [] | A [mm] | F_{zT} [N] | F_{zT} [N] | F_{zT} [N] | Designation |
| RMK 200-222-26L1-032-021 | 55.174 | 0 | 49.587 | 4300 | 4300 | 4300 | ZST 200-222-1000-R1 |
| RMS 200-323-23L1-032 | 48.808 | 0.4 | 47.204 | 4300 | - | - | ZST 200-222-1000-R1 |
| RMS 200-323-25L1-032 | 53.052 | 0.4 | 49.326 | 4300 | - | - | ZST 200-222-1000-R1 |
| RMS 200-323-27L1-032 | 57.296 | 0.3 | 51.248 | 4300 | - | - | ZST 200-222-1000-R1 |

d = Pitch circle diameter

x = Addendum modification coefficient

A = Distance between pinion axle and rear surface of rack

F_{zT} = Maximum feed force depending on ratio and number of stages

Application-specific dimensioning with cymex® – www.wittenstein-cymex.com

1-stage

up to 28⁴⁾ (H)
clamping hub
diameters

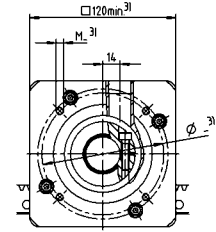
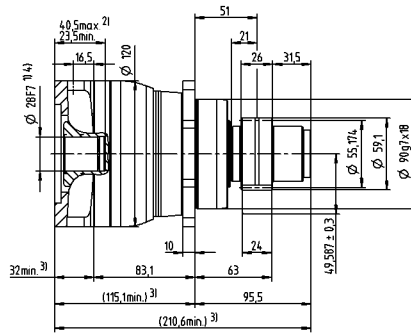
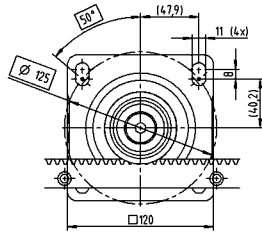

up to 38⁴⁾ (K)
clamping hub
diameters

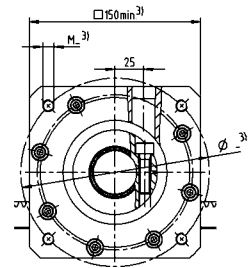
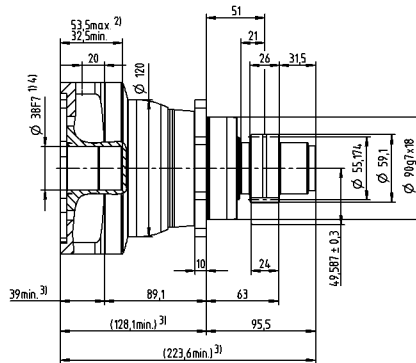
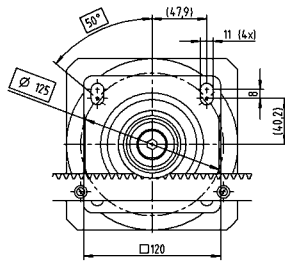

2-stage

up to 19⁴⁾ (E)
clamping hub
diameters

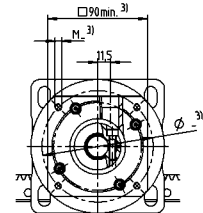
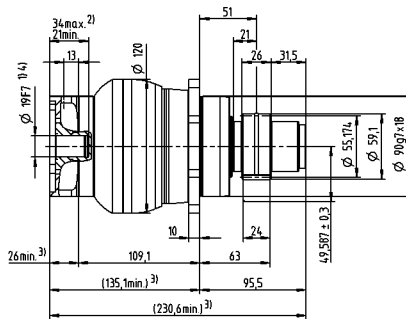
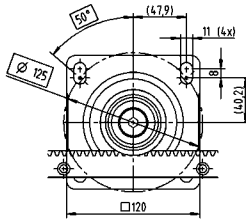

up to 28⁴⁾ (H)
clamping hub
diameters

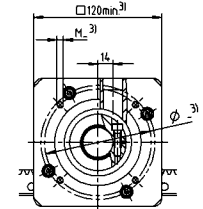
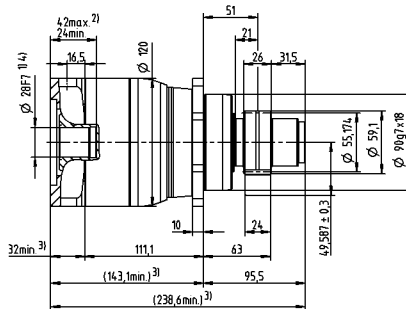
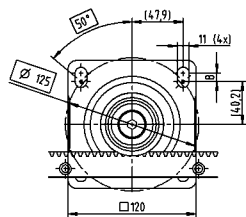

Motor shaft diameter [mm]

Non-tolerated dimensions are nominal dimensions
Detailed rack dimensions starting on page 151

¹⁾ Check motor shaft fit

²⁾ Min./Max. permissible motor shaft length. Longer motor shafts are possible, please contact alpha.

³⁾ The dimensions depend on the motor

⁴⁾ Smaller motor shaft diameter is compensated by a bushing with a minimum thickness of 1 mm

Value Linear System VLS 6 with NPR

Planetary gearbox NPR 035 MF with rack module 3 and pinion RMS module 3

| | | | | |
|---|---|---------------------|---------------------------|--|
| System | Max. feed force ¹⁾ F_{2T} | | 6150 N | |
| | Max. feed speed ²⁾ v_{max} | | 400 m/min | 156 m/min |
| Gearbox | No. of stages | | 1 | 2 |
| | Ratios i | | 3 / 4 / 5 / 7 / 8 / 10 | 9 / 12 / 15 / 16 / 20 / 25 / 28 / 30 / 32 / 35 / 40 / 50 / 64 / 70 / 100 |
| | Clamping hub diameter | | 19 / 24 / 28 / 32 / 38 mm | 14 / 16 / 19 / 24 / 28 mm |
| | Designation | | NPR 035S-MF1-_-_-_-2_-_- | NPR 035S-MF2-_-_-_-2_-_- |
| Pinion | Module m | | 3 mm | |
| | Number of teeth z | | 20 | |
| | Pitch circle diameter d | | 63.662 mm | |
| | Profile correction factor x | | 0.4 | |
| | Helix angle β | | -19.5283° (left-handed) | |
| | Designation | | RMS 300-323-20L1-032 | |
| Rack | Module m | | 3 mm | |
| | Lengths L | | 1000 mm | |
| | Helix angle β | | 19.5283° (right-handed) | |
| | Designation | | ZST 300-222-1000-R1 | |
| Lubrication system ³⁾ | Set consisting of lubrication pinion and axis for | Rack | LMT 300-PU -18L1-030-1 | |
| | | Pinion | LMT 300-PU -18R1-030-1 | |
| | Lubricator | 125 cm ³ | LUC+125-0511-02 | |
| | | 400 cm ³ | LUC+400-0511-02 | |
| | Lubricant | | WITTENSTEIN alpha G11 | |

¹⁾ Maximum feed force depending on ratio and number of stages

²⁾ Calculation with lowest ratio and maximum input speed

³⁾ Impulse-controlled basic version with one output and 2 m hose. See page 116 for further information on the lubrication system.

Application-specific dimensioning with cymex® – www.wittenstein-cymex.com

Alternative system solutions

| Pinion | | | Axis distance | NPS/ NPL/ NPR 035S | NP 035S | Rack |
|--------------------------|-------------|------------|---------------|--------------------|-----------------|---------------------|
| Designation | d [mm] | x [] | A [mm] | F_{2T} [N] | F_{2T} [N] | Designation |
| RMK 200-222-26L1-032-021 | 55.174 | 0 | 49.587 | 4300 | 4300 | ZST 200-222-1000-R1 |
| RMS 200-323-23L1-032 | 48.808 | 0.4 | 47.204 | 4300 | - | ZST 200-222-1000-R1 |
| RMS 200-323-25L1-032 | 53.052 | 0.4 | 49.326 | 4300 | - | ZST 200-222-1000-R1 |
| RMS 200-323-27L1-032 | 57.296 | 0.3 | 51.248 | 4300 | - | ZST 200-222-1000-R1 |
| RMS 300-323-20L1-032 | 63.662 | 0.4 | 59.031 | 6150 | - | ZST 300-222-1000-R1 |

d = Pitch circle diameter

x = Addendum modification coefficient

A = Distance between pinion axle and rear surface of rack

F_{2T} = Maximum feed force depending on ratio and number of stages

Application-specific dimensioning with cymex® – www.wittenstein-cymex.com

1-stage

up to 28⁴⁾ (H) clamping hub diameters

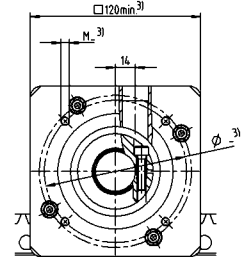
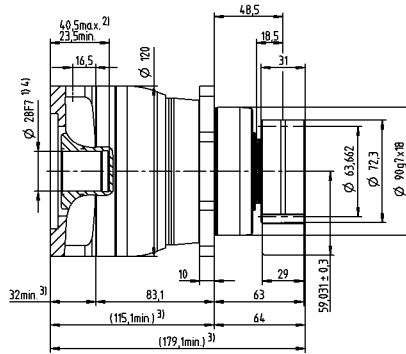
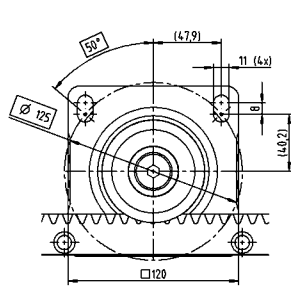

up to 38⁴⁾ (K) clamping hub diameters

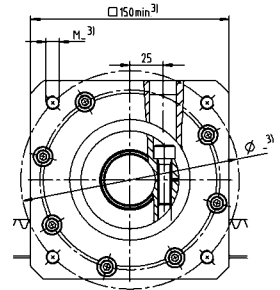
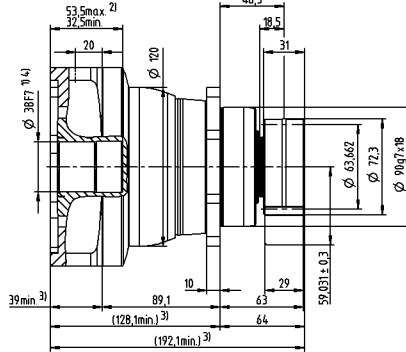
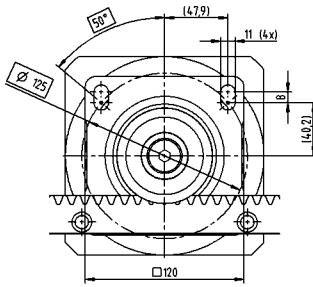

2-stage

up to 19⁴⁾ (E) clamping hub diameters

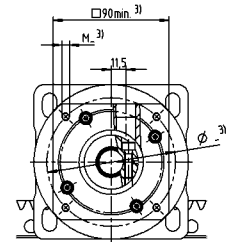
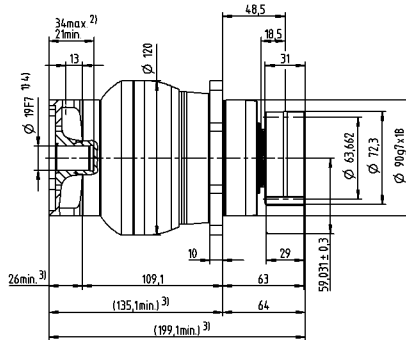
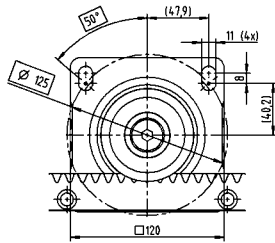

up to 28⁴⁾ (H) clamping hub diameters

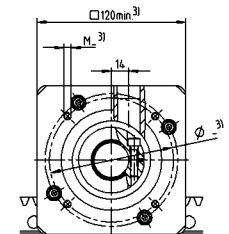
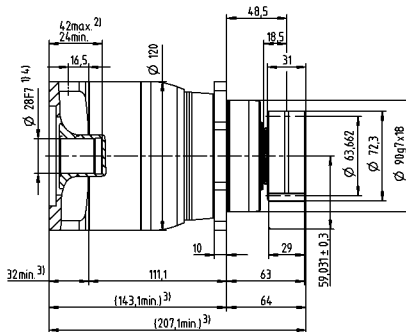
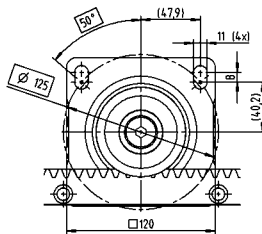

Motor shaft diameter [mm]

Non-tolerated dimensions are nominal dimensions
Detailed rack dimensions starting on page 151

¹⁾ Check motor shaft fit

²⁾ Min./Max. permissible motor shaft length. Longer motor shafts are possible, please contact alpha.

³⁾ The dimensions depend on the motor

⁴⁾ Smaller motor shaft diameter is compensated by a bushing with a minimum thickness of 1 mm

Value Linear System VLS 8 with NPR

Planetary gearbox NPR 045 MF with rack module 3 and pinion RMS module 3

| | | | | |
|---|---|---------------------|--------------------------|---------------------------|
| System | Max. feed force ¹⁾ F_{zT} | | 8000 N | |
| | Max. feed speed ²⁾ v_{max} | | 160 m/min | 48 m/min |
| Gearbox | No. of stages | | 1 | 2 |
| | Ratios i | | 5 / 8 / 10 | 25 / 32 / 50 / 64 / 100 |
| | Clamping hub diameter | | 38 mm | 19 / 24 / 28 / 32 / 38 mm |
| | Designation | | NPR 045S-MF1-_-_-_-2_-_- | NPR 045S-MF2-_-_-_-2_-_- |
| Pinion | Module m | | 3 mm | |
| | Number of teeth z | | 20 | |
| | Pitch circle diameter d | | 63.662 mm | |
| | Profile correction factor x | | 0.4 | |
| | Helix angle β | | -19.5283° (left-handed) | |
| | Designation | | RMS 300-323-20L1-040 | |
| Rack | Module m | | 3 mm | |
| | Lengths L | | 1000 mm | |
| | Helix angle β | | 19.5283° (right-handed) | |
| | Designation | | ZST 300-222-1000-R1 | |
| Lubrication system ³⁾ | Set consisting of lubrication pinion and axis for | Rack | LMT 300-PU -18L1-030-1 | |
| | | Pinion | LMT 300-PU -18R1-030-1 | |
| | Lubricator | 125 cm ³ | LUC+125-0511-02 | |
| | | 400 cm ³ | LUC+400-0511-02 | |
| | Lubricant | | WITTENSTEIN alpha G11 | |

¹⁾ Maximum feed force depending on ratio and number of stages

²⁾ Calculation with lowest ratio and maximum input speed

³⁾ Impulse-controlled basic version with one output and 2 m hose. See page 116 for further information on the lubrication system.
Application-specific dimensioning with cymex® – www.wittenstein-cymex.com

Alternative system solutions

| Pinion | | | Axis distance | NPS/ NPL/ NPR 045S | NP 045S | Rack |
|--------------------------|-------------|------------|---------------|--------------------|-----------------|---------------------|
| Designation | d [mm] | x [] | A [mm] | F_{zT} [N] | F_{zT} [N] | Designation |
| RMK 300-222-24L1-040-035 | 76.394 | 0 | 64.197 | 8000 | 7000 | ZST 300-222-1000-R1 |
| RMS 300-323-20L1-040 | 63.662 | 0.4 | 59.031 | 8000 | – | ZST 300-222-1000-R1 |
| RMS 300-323-22L1-040 | 70.028 | 0.4 | 62.214 | 8000 | – | ZST 300-222-1000-R1 |
| RMS 300-323-24L1-040 | 76.394 | 0.4 | 65.397 | 8000 | – | ZST 300-222-1000-R1 |

d = Pitch circle diameter

x = Addendum modification coefficient

A = Distance between pinion axle and rear surface of rack

F_{zT} = Maximum feed force depending on ratio and number of stages

Application-specific dimensioning with cymex® – www.wittenstein-cymex.com

1-stage

up to 38⁴⁾ (K)
clamping hub
diameters

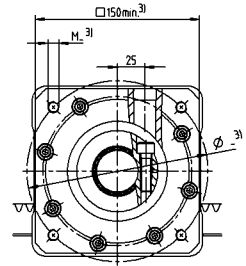
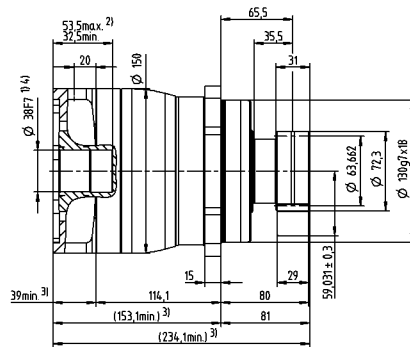
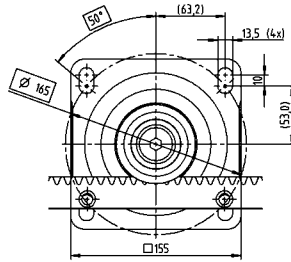

up to 28⁴⁾ (H)
clamping hub
diameters

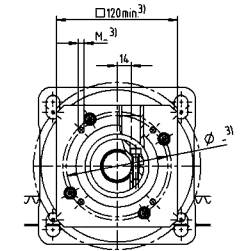
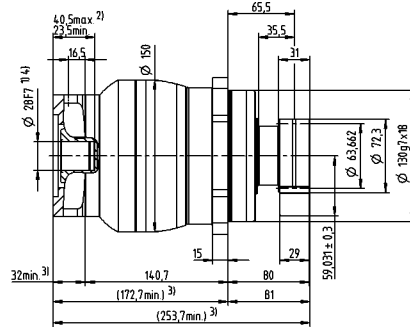
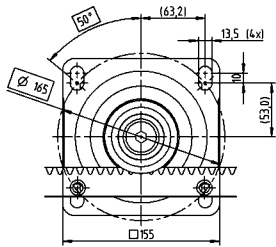

2-stage

up to 38⁴⁾ (K)
clamping hub
diameters

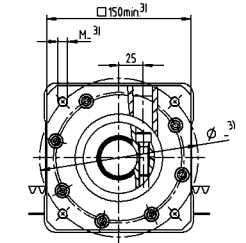
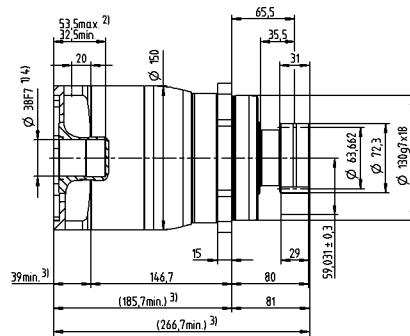
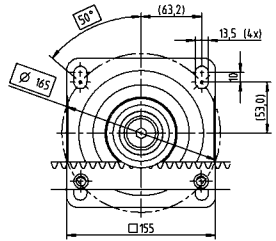

Motor shaft diameter [mm]

Value Linear Systems

Non-tolerated dimensions are nominal dimensions
Detailed rack dimensions starting on page 151
1) Check motor shaft fit
2) Min./Max. permissible motor shaft length. Longer motor shafts are possible, please contact alpha.
3) The dimensions depend on the motor
4) Smaller motor shaft diameter is compensated by a bushing with a minimum thickness of 1 mm

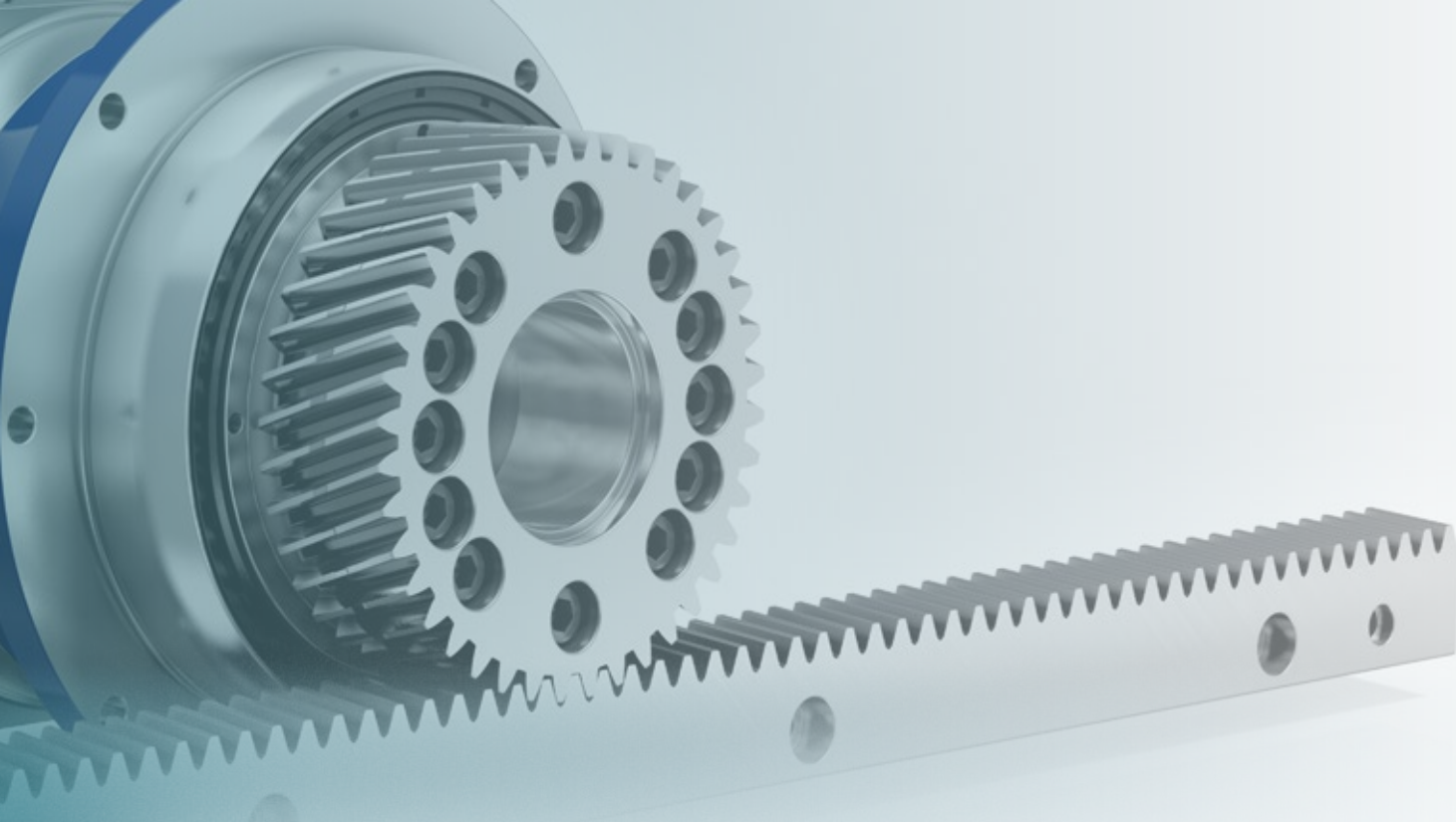

Advanced Linear Systems from WITTENSTEIN alpha –
outstanding performance in the Advanced Segment

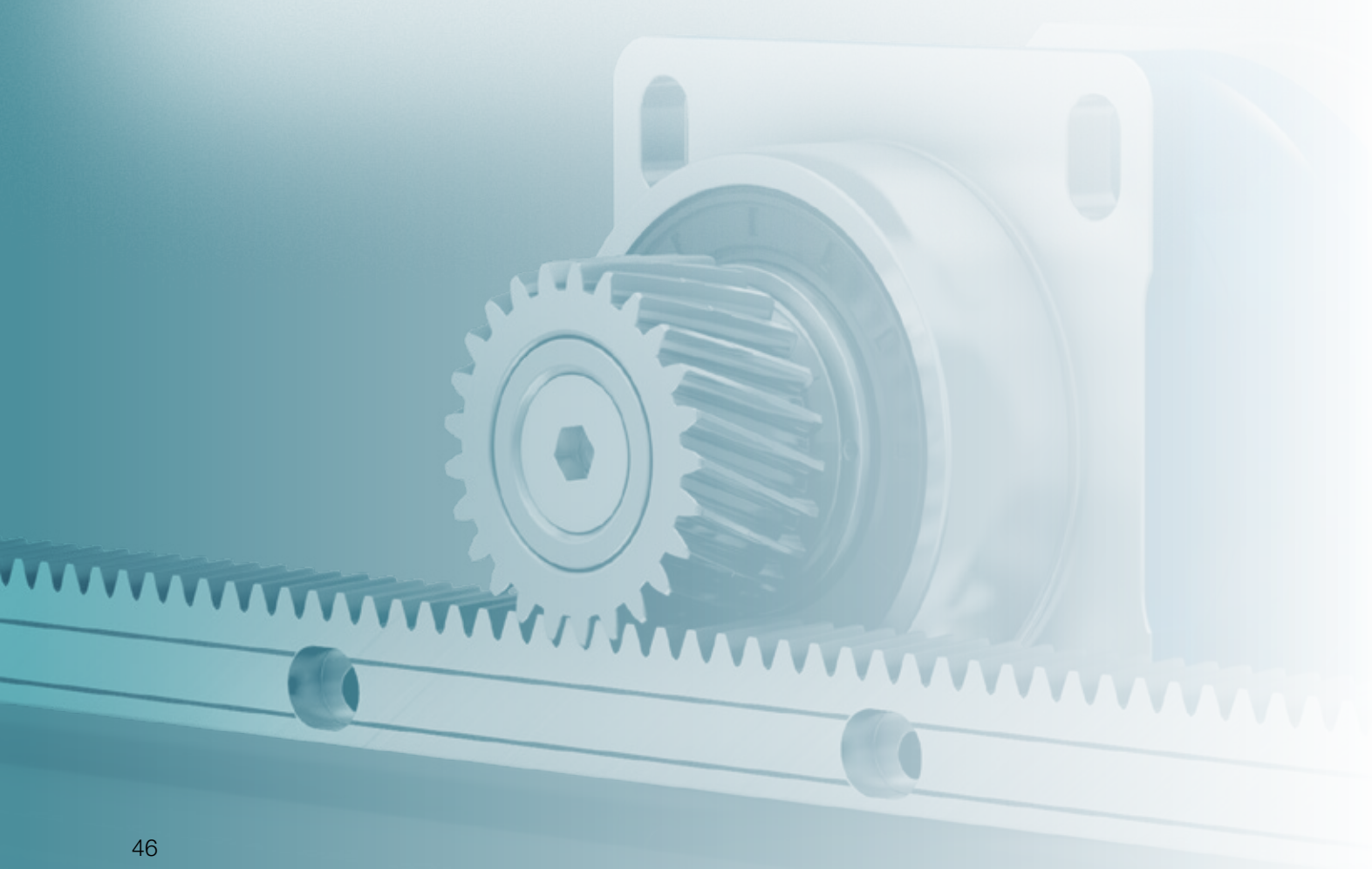

Advanced Linear Systems – the perfect solution for linear feed drives for almost every automation, wood working and machine tool application

The Advanced Linear System with **SP+** and associated right-angle versions is used predominantly as a single drive within a range of up to 12,000 N/drive.

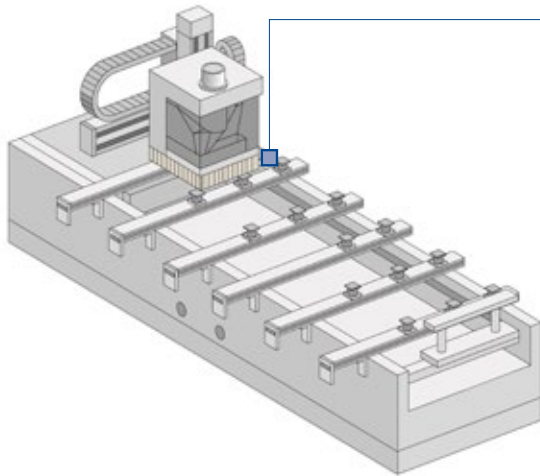

Wood working machine

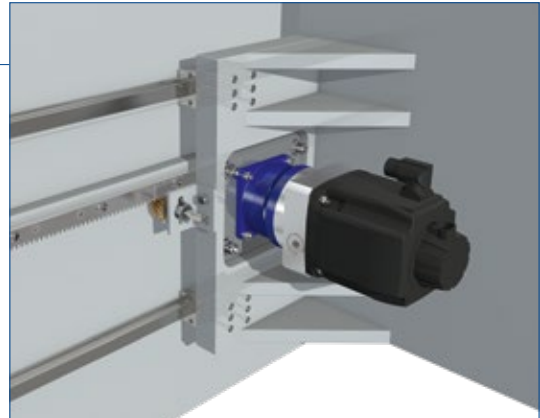

The Advanced Linear System with **TP+** or **TP+ HIGH TORQUE** and associated right-angle versions is used as a single drive or master/slave drive within a range of up to 21,000 N/drive.

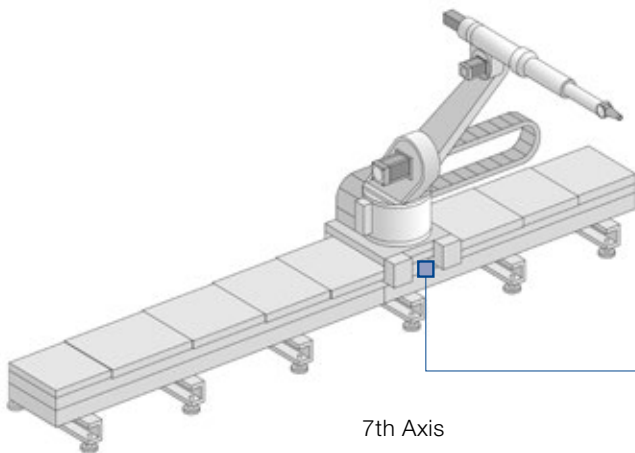

7th Axis

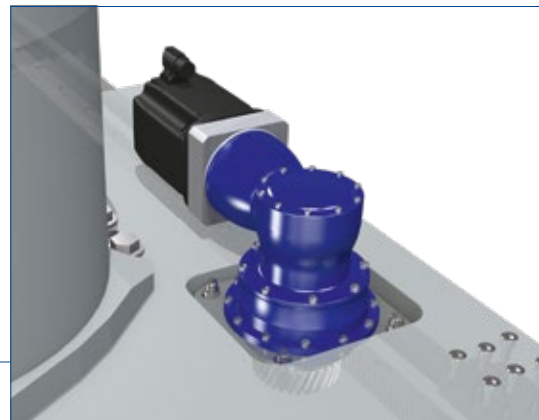

Outstanding performance in the Advanced Segment

These systems are adapted to applications with average to high demands in terms of smooth running, positioning accuracy and feed force. Different gearbox versions and options such as HIGH TORQUE or HIGH SPEED can be selected to choose the best system for the application.

Your benefits

- Perfectly adapted linear systems available with planetary, right-angle and worm gearboxes or as an servo actuator
- Optionally with INIRA®
- Large individual configuration range due to numerous pinion/gearbox combinations

| | | Advanced Linear System | Max. feed force [N] | Max. feed speed [m/min] |
|----------|----|------------------------|---------------------|-------------------------|
| with SP+ | | ALS 2 | 2230 | 250 |
| | | ALS 3 | 3250 | 300 |
| | | ALS 6 | 6050 | 281 |
| | | ALS 8 | 8000 | 333 |
| | | ALS 12 | 12500 | 400 |
| with TP+ | MF | ALS 1 | 1370 | 325 |
| | | ALS 2 | 2500 | 412 |
| | | ALS 3 | 3600 | 367 |
| | | ALS 12 | 11800 | 438 |
| | | ALS 20 | 19700 | 570 |
| | MA | ALS 4 | 4200 | 45 |
| | | ALS 11 | 10900 | 57 |
| | | ALS 21 | 21000 | 68 |

Feed force and feed speed dependent on ratio



SP+



TP+ MF



TP+ MA

Quick system selection

- SP+
- TP+ MF
- TP+ MA

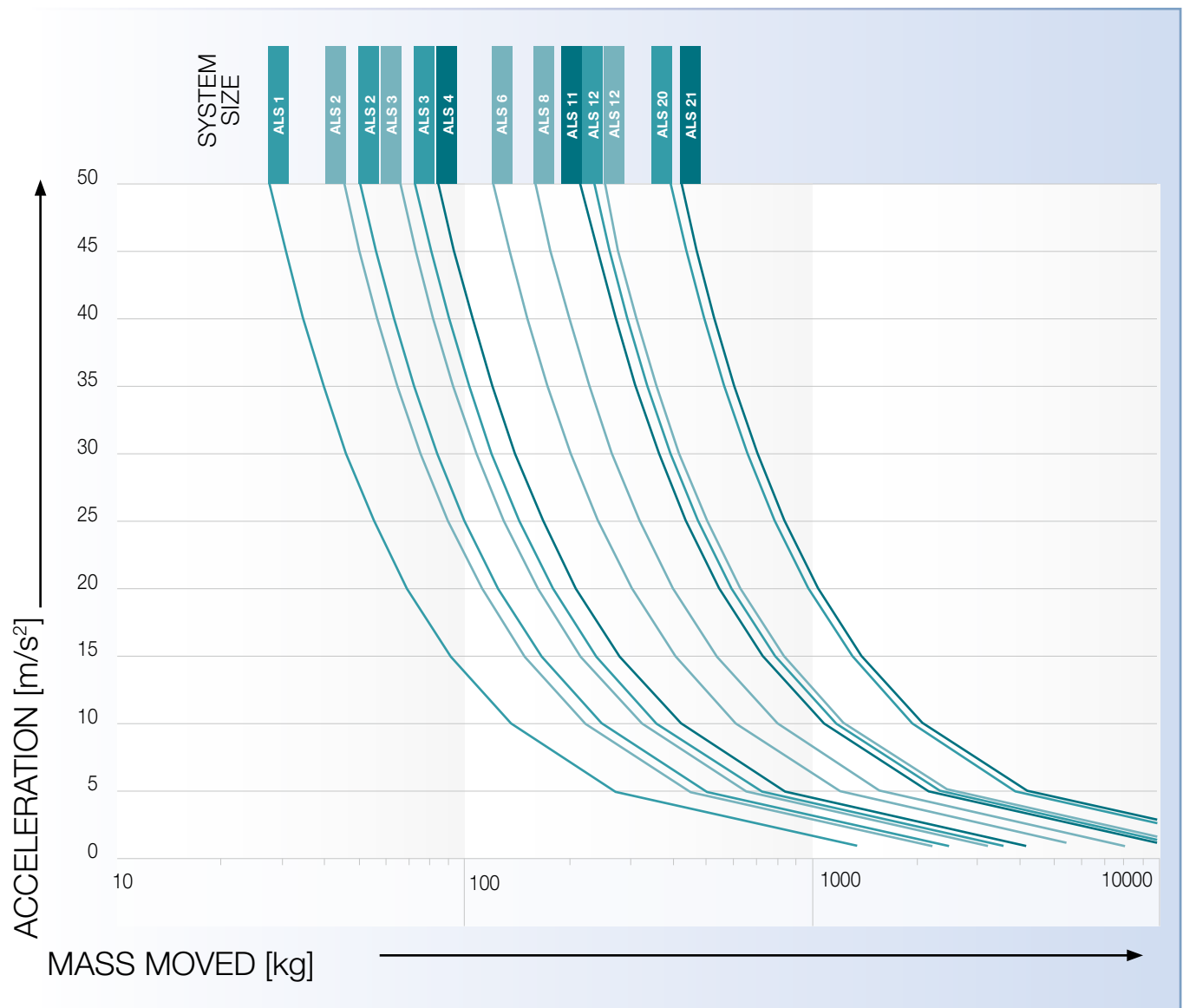

Advanced Linear Systems

Advanced Linear Systems overview

Our preferred linear systems are always comprised of the perfect combination of gearbox, pinion, rack and lubrication system. The systems are optimized to achieve the required feed force, feed speed, rigidity and degree of utilization of the individual components. Depending on your individual requirements, you have the option to further configure products via the ordering code. For a detailed dimensioning and configuration of the products we recommend to use cymex® 5.

| System | Gearbox | Pinion | Rack |
|--------|------------|-----------------------------|----------------------|
| ALS 2 | SP* 060R | RMS 200-323-15L1-016 | ZST 200-332-1000-R1 |
| ALS 3 | SP* 075R | RMS 200-323-18L1-022 | ZST 200-332-1000-R1 |
| ALS 6 | SP* 100R | RMS 200-323-23L1-032 | ZST 200-333-1000-R1 |
| ALS 8 | SP* 140R | RMS 300-323-20L1-040 | ZST 300-332-1000-R1 |
| ALS 12 | SP* 180 | RMS 400-323-20L1-055 | ZST 400-332-1000-R1 |
| ALS 1 | TP* 004 MF | RMF 200-443-26L1-031-8xM5 | ZST 200-332-1000-R1 |
| ALS 2 | TP* 010 MF | RMF 200-443-33L1-050-8xM6 | ZST 200-332-1000-R1 |
| ALS 3 | TP* 025 MF | RMF 200-443-40L1-063-12xM6 | ZST 200-332-1000-R1 |
| ALS 12 | TP* 050 MF | RMF 300-443-35L1-080-12xM8 | ZST 300-333-1000-R1 |
| ALS 20 | TP* 110 MF | RMF 400-443-38L1-125-12xM10 | ZST 400-334-1000-R11 |
| ALS 4 | TP* 025 MA | RMW 200-444-20L1-037 | ZST 200-332-1000-R1 |
| ALS 11 | TP* 050 MA | RMW 300-444-20L1-055 | ZST 300-333-1000-R1 |
| ALS 21 | TP* 110 MA | RMW 400-444-20L1-073 | ZST 400-334-1000-R11 |

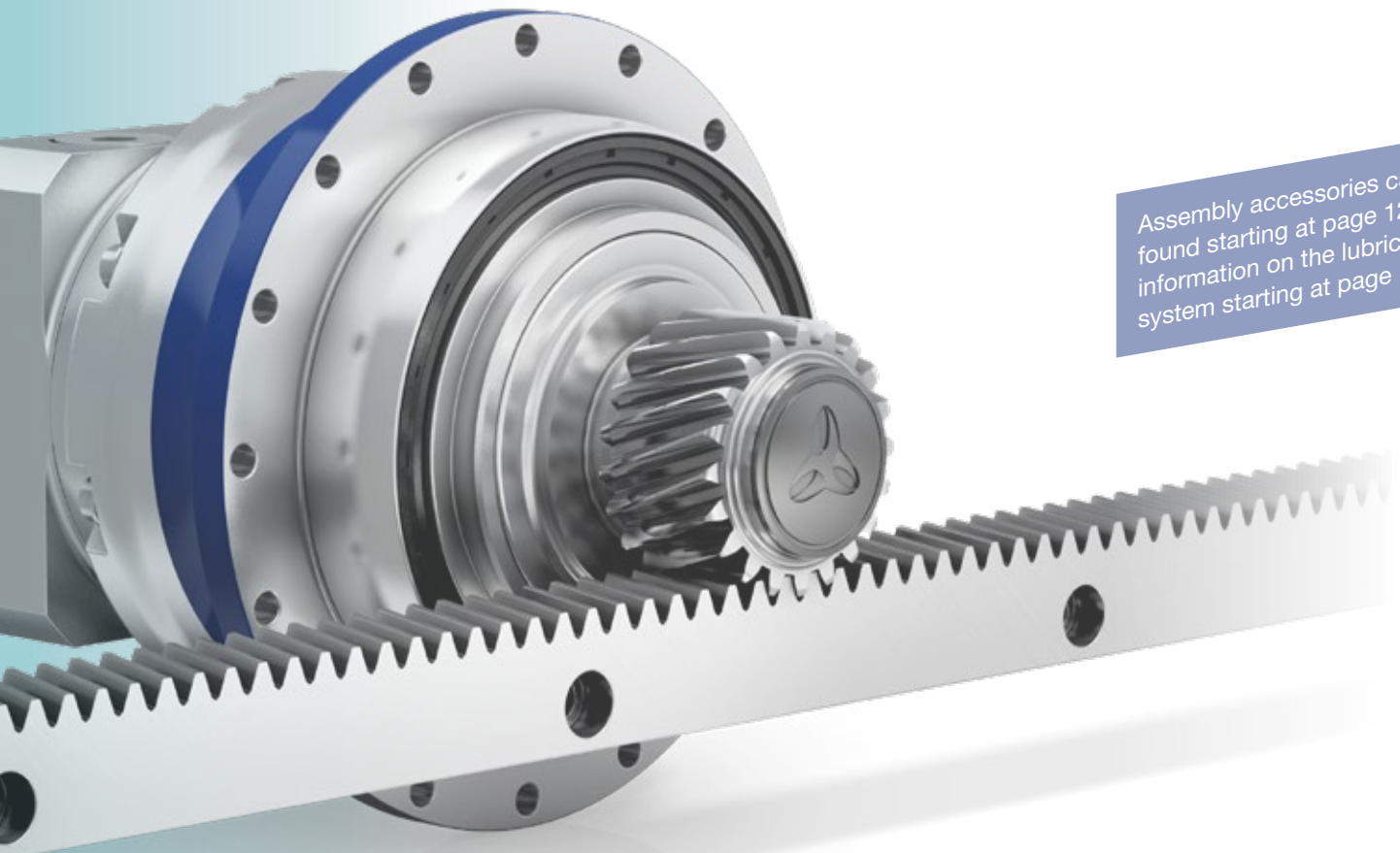

Assembly accessories can be found starting at page 128 and information on the lubrication system starting at page 116

Ordering code

Gearbox*

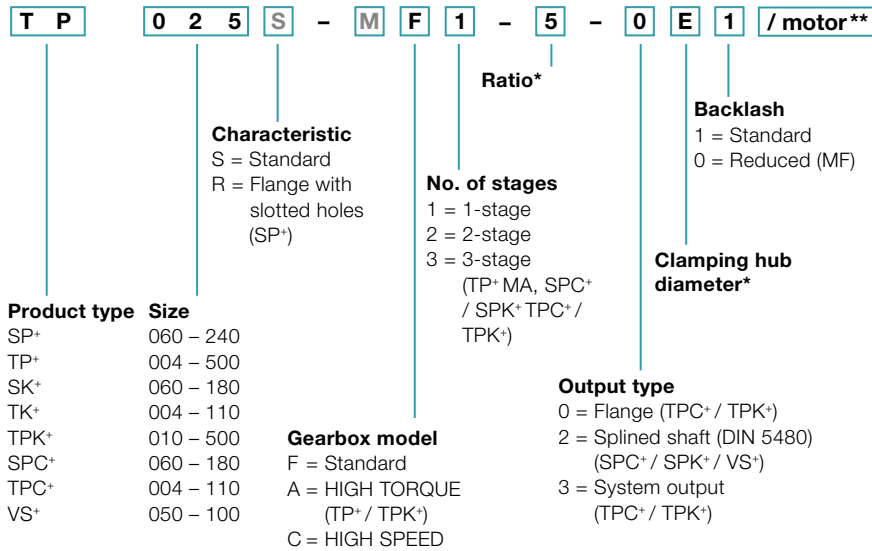

M Components with a gray font cannot be selected

* Further information on the gearboxes can be obtained from the respective catalogs, online at www.wittenstein-alpha.com or on request

** Full motor designation only required for determining gearbox mounting parts

Rack

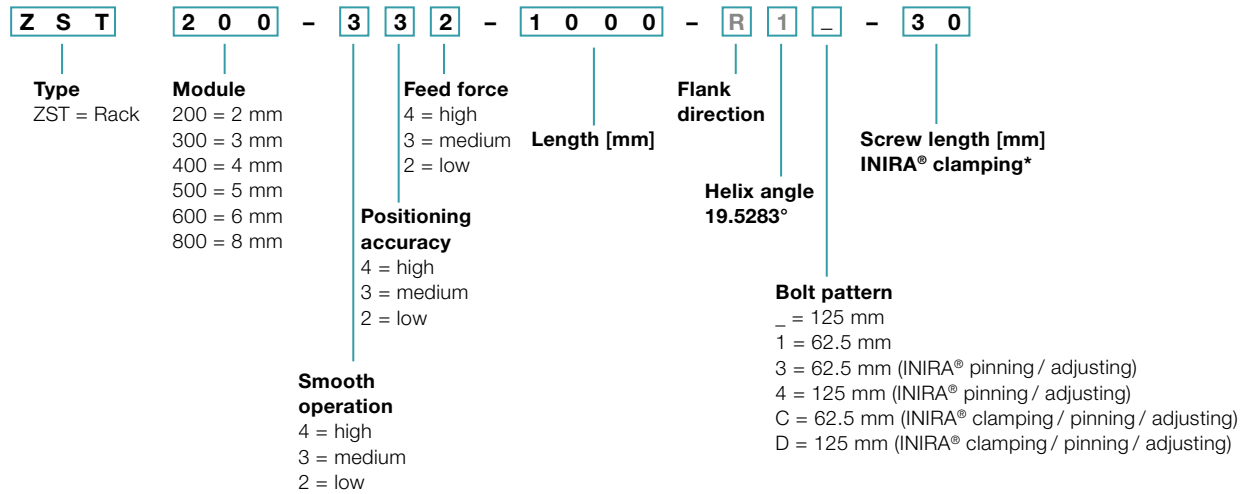

* Please refer to page 130 for an overview of available screw lengths

Pinion

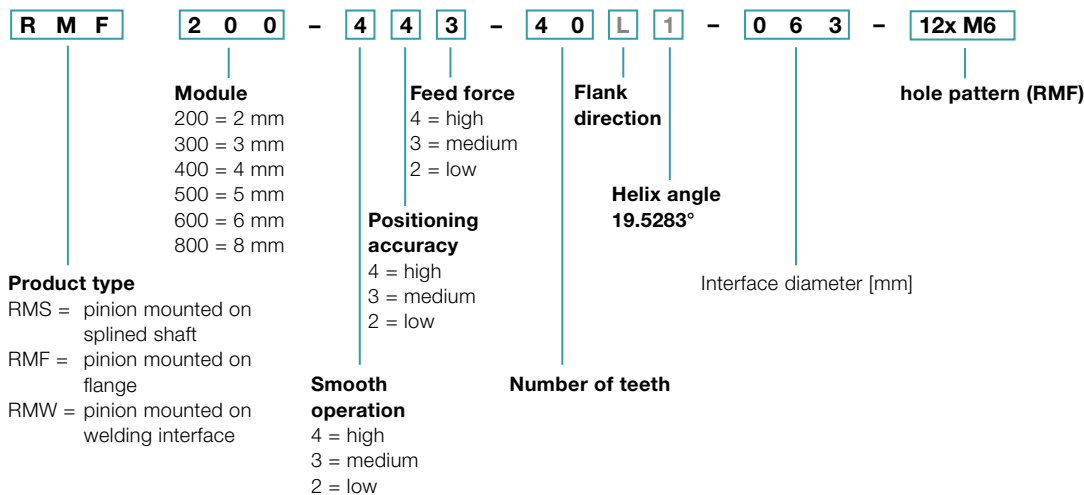

Advanced Linear System ALS 2 with SP+

Planetary gearbox SP+ 060R MF with rack module 2 and pinion RMS module 2

| | | | | |
|---|---|---------------------|---|---|
| System | Max. feed force ¹⁾ F_{2T} | | 2230 N | |
| | Max. feed speed ²⁾ v_{max} | | 250 m/min | 53 m/min |
| Gearbox | No. of stages | | 1 | 2 |
| | Ratios i | | 3 / 4 / 5 / 7 / 8 / 10 | 16 / 20 / 25 / 28 / 32 / 35 / 40 / 50 / 64 / 70 / 100 |
| | Clamping hub diameter | | 11 / 14 / 19 mm | 11 / 14 mm |
| | Designation | | SP 060S-MF1-_-_-_-2_-_- | SP 060S-MF2-_-_-_-2_-_- |
| Pinion | Module m | | 2 mm | |
| | Number of teeth z | | 15 | |
| | Pitch circle diameter d | | 31.831 mm | |
| | Profile correction factor x | | 0.5 | |
| | Helix angle β | | -19.5283° (left-handed) | |
| | Designation | | RMS 200-323-15L1-016 | |
| Rack | Module m | | 2 mm | |
| | Lengths L | | 1000 mm (500 mm) | |
| | Helix angle β | | 19.5283° (right-handed) | |
| | Designation | | ZST 200-332-1000-R1; optionally with INIRA® | |
| Lubrication system ³⁾ | Set consisting of lubrication pinion and axis for | Rack | LMT 200-PU -18L1-024-1 | |
| | | Pinion | LMT 200-PU -18R1-024-1 | |
| | Lubricator | 125 cm ³ | LUC+125-0511-02 | |
| | | 400 cm ³ | LUC+400-0511-02 | |
| | Lubricant | | WITTENSTEIN alpha G11 | |

¹⁾ Maximum feed force depending on ratio and number of stages

²⁾ Calculation with lowest ratio and maximum input speed

³⁾ Impulse-controlled basic version with one output and 2 m hose. See page 116 for further information on the lubrication system. Application-specific dimensioning with cymex® – www.wittenstein-cymex.com

Alternative system solutions

| Pinion | | | Axis distance | SP+ 060R | PBG 1 | SK+ 060S | SPC+ 060S | Rack |
|--------------------------|----------|---------|---------------|--------------|--------------|--------------|--------------|---|
| Designation | d [mm] | x [] | A [mm] | F_{2T} [N] | F_{2T} [N] | F_{2T} [N] | F_{2T} [N] | Designation |
| RMK 200-222-18L1-016-019 | 38.197 | 0.4 | 41.899 | 2190 | 2190 | 1560 | 2190 | ZST 200-332-1000-R1; optionally with INIRA® |
| RMS 200-323-15L1-016 | 31.831 | 0.5 | 38.916 | 2230 | 2230 | 1880 | 2230 | ZST 200-332-1000-R1; optionally with INIRA® |
| RMS 200-323-16L1-016 | 33.953 | 0.5 | 39.977 | 2220 | 2220 | 1760 | 2220 | ZST 200-332-1000-R1; optionally with INIRA® |
| RMS 200-323-18L1-016 | 38.197 | 0.4 | 41.899 | 2190 | 2190 | 1560 | 2190 | ZST 200-332-1000-R1; optionally with INIRA® |

d = Pitch circle diameter

x = Addendum modification coefficient

A = Distance between pinion axle and rear surface of rack

F_{2T} = Maximum feed force depending on ratio and number of stages

Application-specific dimensioning with cymex® – www.wittenstein-cymex.com

1-stage

greater than 11 (B) up to 14⁴⁾ (C) clamping hub diameters

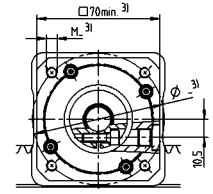
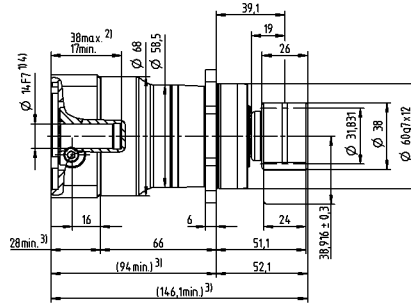
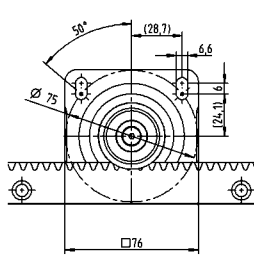

up to 19⁴⁾ (E) clamping hub diameters

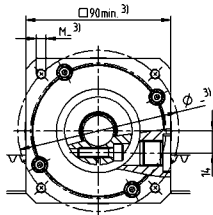
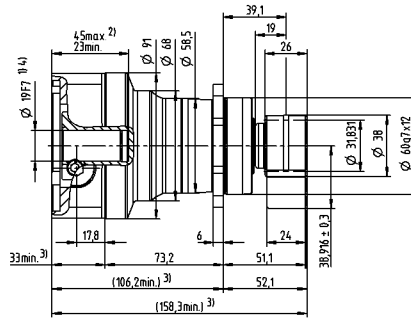
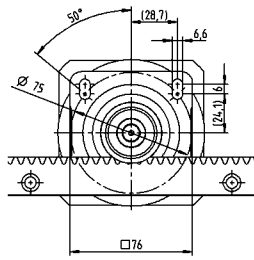

2-stage

up to 11⁴⁾ (B) clamping hub diameters

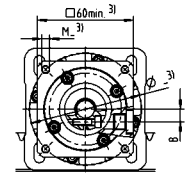
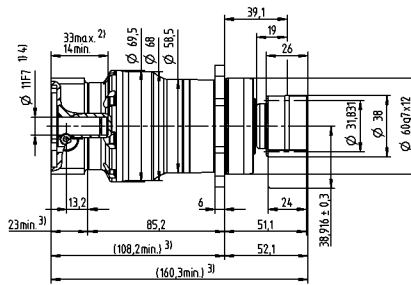
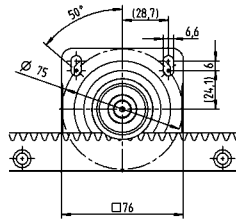

up to 14⁴⁾ (C) clamping hub diameters

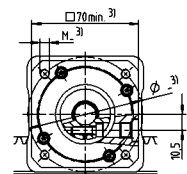
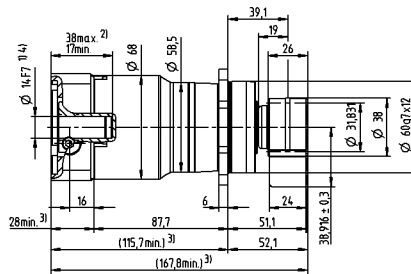
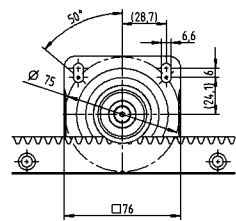

Motor shaft diameter [mm]

Non-tolerated dimensions are nominal dimensions
Detailed rack dimensions starting on page 151

¹⁾ Check motor shaft fit

²⁾ Min./Max. permissible motor shaft length. Longer motor shafts are possible, please contact alpha.

³⁾ The dimensions depend on the motor

⁴⁾ Smaller motor shaft diameter is compensated by a bushing with a minimum thickness of 1 mm

Advanced Linear System ALS 3 with SP+

Planetary gearbox SP+ 075R MF with rack module 2 and pinion RMS module 2

| | | | | |
|---|---|---------------------|---|---|
| System | Max. feed force ¹⁾ F_{2T} | | 3250 N | |
| | Max. feed speed ²⁾ v_{max} | | 300 m/min | 64 m/min |
| Gearbox | No. of stages | | 1 | 2 |
| | Ratios i | | 3 / 4 / 5 / 7 / 8 / 10 | 16 / 20 / 25 / 28 / 32 / 35 / 40 / 50 / 64 / 70 / 100 |
| | Clamping hub diameter | | 14 / 19 / 24 mm | 11 / 14 / 19 mm |
| | Designation | | SP 075S-MF1-_-_-_-2_-_- | SP 075S-MF2-_-_-_-2_-_- |
| Pinion | Module m | | 2 mm | |
| | Number of teeth z | | 18 | |
| | Pitch circle diameter d | | 38.197 mm | |
| | Profile correction factor x | | 0.4 | |
| | Helix angle β | | -19.5283° (left-handed) | |
| | Designation | | RMS 200-323-18L1-022 | |
| Rack | Module m | | 2 mm | |
| | Lengths L | | 1000 mm (500 mm) | |
| | Helix angle β | | 19.5283° (right-handed) | |
| | Designation | | ZST 200-332-1000-R1; optionally with INIRA® | |
| Lubrication system ³⁾ | Set consisting of lubrication pinion and axis for | Rack | LMT 200-PU -18L1-024-1 | |
| | | Pinion | LMT 200-PU -18R1-024-1 | |
| | Lubricator | 125 cm ³ | LUC+125-0511-02 | |
| | | 400 cm ³ | LUC+400-0511-02 | |
| | Lubricant | | WITTENSTEIN alpha G11 | |

¹⁾ Maximum feed force depending on ratio and number of stages

²⁾ Calculation with lowest ratio and maximum input speed

³⁾ Impulse-controlled basic version with one output and 2 m hose. See page 116 for further information on the lubrication system. Application-specific dimensioning with cymex® – www.wittenstein-cymex.com

Alternative system solutions

| Pinion | | | Axis distance | SP+ 075R | PBG 2 | SK+ 075S | SPC+ 075S | SPK+ 075S | Rack |
|--------------------------|----------|---------|---------------|--------------|--------------|--------------|--------------|--------------|---|
| Designation | d [mm] | x [] | A [mm] | F_{2T} [N] | F_{2T} [N] | F_{2T} [N] | F_{2T} [N] | F_{2T} [N] | Designation |
| RMK 200-222-22L1-022-020 | 46.686 | 0.2 | 45.743 | 3220 | 3220 | 2980 | 3220 | 3220 | ZST 200-332-1000-R1; optionally with INIRA® |
| RMS 200-323-18L1-022 | 38.197 | 0.4 | 41.899 | 3250 | 3250 | 3380 | 3250 | 3250 | ZST 200-332-1000-R1; optionally with INIRA® |
| RMS 200-323-20L1-022 | 42.441 | 0.4 | 44.021 | 3240 | 3240 | 3280 | 3240 | 3240 | ZST 200-332-1000-R1; optionally with INIRA® |
| RMS 200-323-22L1-022 | 46.686 | 0.4 | 46.143 | 3220 | 3220 | 2980 | 3220 | 3220 | ZST 200-332-1000-R1; optionally with INIRA® |

d = Pitch circle diameter

x = Addendum modification coefficient

A = Distance between pinion axle and rear surface of rack

F_{2T} = Maximum feed force depending on ratio and number of stages

Application-specific dimensioning with cymex® – www.wittenstein-cymex.com

1-stage

greater than 14 (C) up to 19⁴⁾ (E) clamping hub diameters

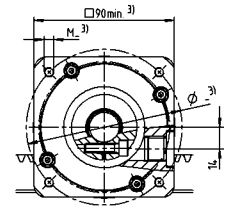
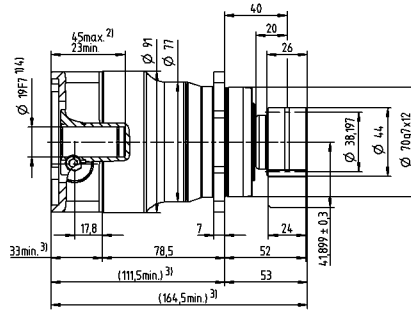
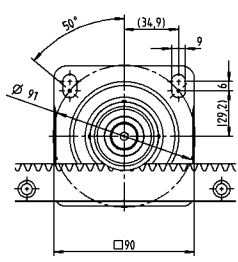

up to 24⁴⁾ (G) clamping hub diameters

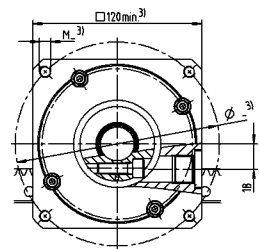
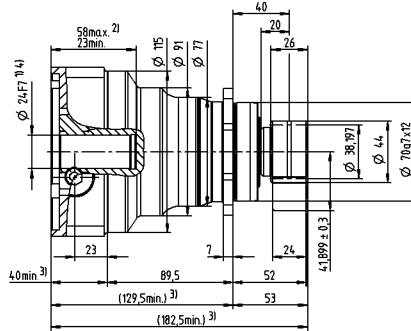
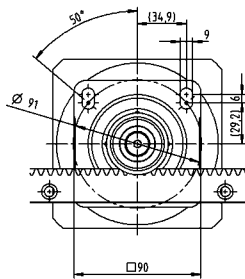

2-stage

greater than 11 (B) up to 14⁴⁾ (C) clamping hub diameters

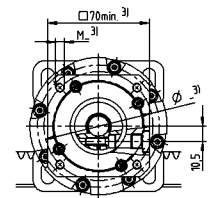
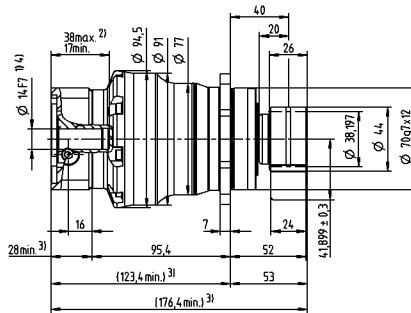
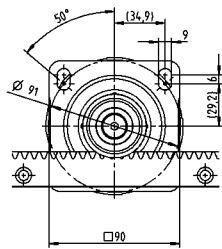

up to 19⁴⁾ (E) clamping hub diameters

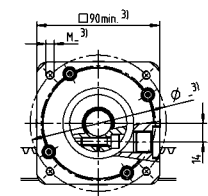
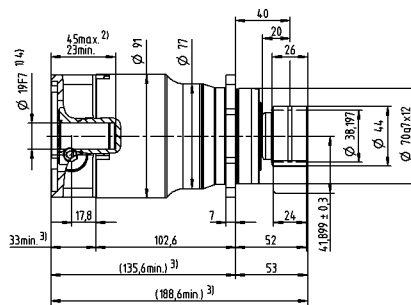
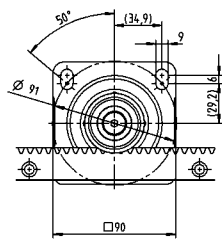

Motor shaft diameter [mm]

Non-tolerated dimensions are nominal dimensions
Detailed rack dimensions starting on page 151

¹⁾ Check motor shaft fit

²⁾ Min./Max. permissible motor shaft length. Longer motor shafts are possible, please contact alpha.

³⁾ The dimensions depend on the motor

⁴⁾ Smaller motor shaft diameter is compensated by a bushing with a minimum thickness of 1 mm

Advanced Linear System ALS 6 with SP+

Planetary gearbox SP+ 100R MF with rack module 2 and pinion RMS module 2

| | | | | |
|---|---|---------------------|---|---|
| System | Max. feed force ¹⁾ F_{2T} | | 6050 N | |
| | Max. feed speed ²⁾ v_{max} | | 281 m/min | 62 m/min |
| Gearbox | No. of stages | | 1 | 2 |
| | Ratios i | | 3 / 4 / 5 / 7 / 8 / 10 | 16 / 20 / 25 / 28 / 32 / 35 / 40 / 50 / 64 / 70 / 100 |
| | Clamping hub diameter | | 19 / 24 / 28 / 38 mm | 14 / 19 / 24 / 28 mm |
| | Designation | | SP 100S-MF1-_-_-_-2_-_- | SP 100S-MF2-_-_-_-2_-_- |
| Pinion | Module m | | 2 mm | |
| | Number of teeth z | | 23 | |
| | Pitch circle diameter d | | 48.808 mm | |
| | Profile correction factor x | | 0.4 | |
| | Helix angle β | | -19.5283° (left-handed) | |
| | Designation | | RMS 200-323-23L1-032 | |
| Rack | Module m | | 2 mm | |
| | Lengths L | | 1000 mm (500 mm) | |
| | Helix angle β | | 19.5283° (right-handed) | |
| | Designation | | ZST 200-333-1000-R1; optionally with INIRA® | |
| Lubrication system ³⁾ | Set consisting of lubrication pinion and axis for | Rack | LMT 200-PU -18L1-024-1 | |
| | | Pinion | LMT 200-PU -18R1-024-1 | |
| | Lubricator | 125 cm ³ | LUC+125-0511-02 | |
| | | 400 cm ³ | LUC+400-0511-02 | |
| | Lubricant | | WITTENSTEIN alpha G11 | |

¹⁾ Maximum feed force depending on ratio and number of stages

²⁾ Calculation with lowest ratio and maximum input speed

³⁾ Impulse-controlled basic version with one output and 2 m hose. See page 116 for further information on the lubrication system. Application-specific dimensioning with cymex® – www.wittenstein-cymex.com

Alternative system solutions

| Pinion | | | Axis distance | SP+ 100R | PBG 3 | SK+ 100S | SPC+ 100S | SPK+ 100S | Rack |
|--------------------------|----------|---------|---------------|--------------|--------------|--------------|--------------|--------------|---|
| Designation | d [mm] | x [] | A [mm] | F_{2T} [N] | F_{2T} [N] | F_{2T} [N] | F_{2T} [N] | F_{2T} [N] | Designation |
| RMK 200-222-26L1-032-021 | 55.174 | 0 | 49.587 | 6000 | 6000 | 5350 | 6000 | 6000 | ZST 200-333-1000-R1; optionally with INIRA® |
| RMS 200-323-23L1-032 | 48.808 | 0.4 | 47.204 | 6050 | 6050 | 5350 | 6050 | 6050 | ZST 200-333-1000-R1; optionally with INIRA® |
| RMS 200-323-25L1-032 | 53.052 | 0.4 | 49.326 | 6000 | 6000 | 5350 | 6000 | 6000 | ZST 200-333-1000-R1; optionally with INIRA® |
| RMS 200-323-27L1-032 | 57.296 | 0.3 | 51.248 | 6000 | 6000 | 5350 | 6000 | 6000 | ZST 200-333-1000-R1; optionally with INIRA® |

d = Pitch circle diameter

x = Addendum modification coefficient

A = Distance between pinion axle and rear surface of rack

F_{2T} = Maximum feed force depending on ratio and number of stages

Application-specific dimensioning with cymex® – www.wittenstein-cymex.com

1-stage

greater than 19 (E) up to 24/28⁴⁾ (G/H) clamping hub diameters

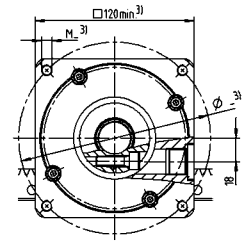
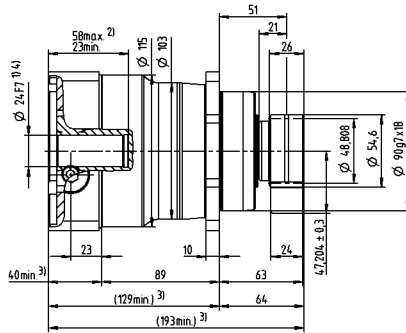
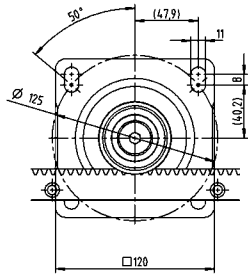

up to 38⁴⁾ (K) clamping hub diameters

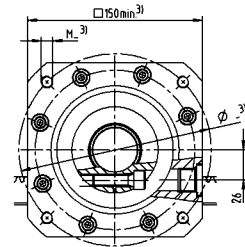
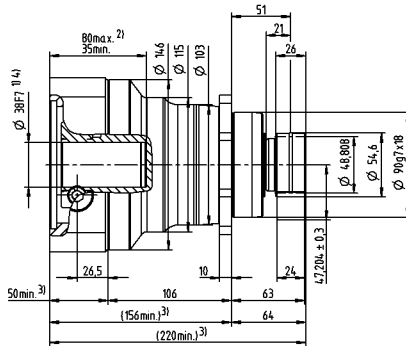
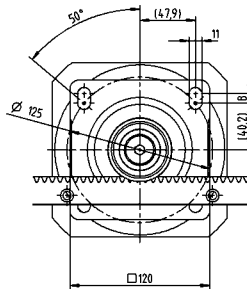

2-stage

greater than 14 (C) up to 19⁴⁾ (E) clamping hub diameters

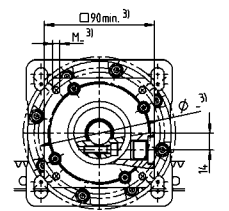
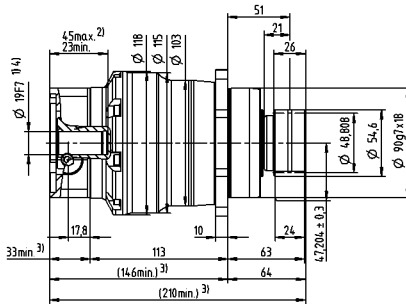
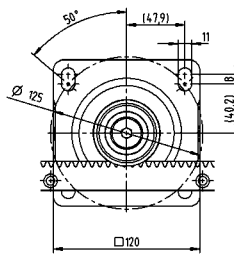

up to 24/28⁴⁾ (G/H) clamping hub diameters

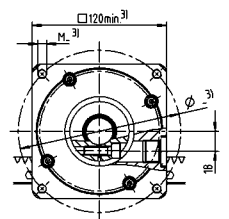
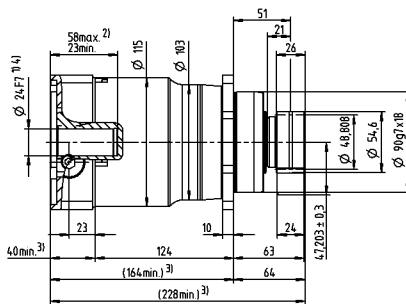
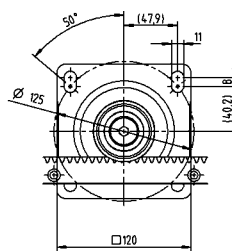

Motor shaft diameter [mm]

Non-tolerated dimensions are nominal dimensions
 Detailed rack dimensions starting on page 151
¹⁾ Check motor shaft fit
²⁾ Min./Max. permissible motor shaft length. Longer motor shafts are possible, please contact alpha.
³⁾ The dimensions depend on the motor
⁴⁾ Smaller motor shaft diameter is compensated by a bushing with a minimum thickness of 1 mm

Advanced Linear System ALS 8 with SP+

Planetary gearbox SP+ 140R MF with rack module 3 and pinion RMS module 3

| | | | | |
|---|---|---------------------|---|---|
| System | Max. feed force ¹⁾ F_{2T} | | 8000 N | |
| | Max. feed speed ²⁾ v_{max} | | 333 m/min | 75 m/min |
| Gearbox | No. of stages | | 1 | 2 |
| | Ratios i | | 3 / 4 / 5 / 7 / 8 / 10 | 16 / 20 / 25 / 28 / 32 / 35 / 40 / 50 / 64 / 70 / 100 |
| | Clamping hub diameter | | 24 / 32 / 38 / 48 mm | 19 / 24 / 38 mm |
| | Designation | | SP 140S-MF1-_-_-_-2_-_- | SP 140S-MF2-_-_-_-2_-_- |
| Pinion | Module m | | 3 mm | |
| | Number of teeth z | | 20 | |
| | Pitch circle diameter d | | 63.662 mm | |
| | Profile correction factor x | | 0.4 | |
| | Helix angle β | | -19.5283° (left-handed) | |
| | Designation | | RMS 300-323-20L1-040 | |
| Rack | Module m | | 3 mm | |
| | Lengths L | | 1000 mm (500 mm) | |
| | Helix angle β | | 19.5283° (right-handed) | |
| | Designation | | ZST 300-332-1000-R1; optionally with INIRA® | |
| Lubrication system ³⁾ | Set consisting of lubrication pinion and axis for | Rack | LMT 300-PU -18L1-030-1 | |
| | | Pinion | LMT 300-PU -18R1-030-1 | |
| | Lubricator | 125 cm ³ | LUC+125-0511-02 | |
| | | 400 cm ³ | LUC+400-0511-02 | |
| | Lubricant | | WITTENSTEIN alpha G11 | |

¹⁾ Maximum feed force depending on ratio and number of stages

²⁾ Calculation with lowest ratio and maximum input speed

³⁾ Impulse-controlled basic version with one output and 2 m hose. See page 116 for further information on the lubrication system. Application-specific dimensioning with cymex® – www.wittenstein-cymex.com

Alternative system solutions

| Pinion | | | Axis distance | SP+ 140R | SK+ 140S | SPC+ 140S | SPK+ 140S | Rack |
|--------------------------|----------|---------|---------------|--------------|--------------|--------------|--------------|---|
| Designation | d [mm] | x [] | A [mm] | F_{2T} [N] | F_{2T} [N] | F_{2T} [N] | F_{2T} [N] | Designation |
| RMK 300-222-24L1-040-035 | 76.394 | 0 | 64.197 | 8000 | 7800 | 8000 | 8000 | ZST 300-332-1000-R1; optionally with INIRA® |
| RMS 300-323-20L1-040 | 63.662 | 0.4 | 59.031 | 8000 | 8000 | 8000 | 8000 | ZST 300-332-1000-R1; optionally with INIRA® |
| RMS 300-323-22L1-040 | 70.028 | 0.4 | 62.214 | 8000 | 8000 | 8000 | 8000 | ZST 300-332-1000-R1; optionally with INIRA® |
| RMS 300-323-24L1-040 | 76.394 | 0.4 | 65.397 | 8000 | 7800 | 8000 | 8000 | ZST 300-332-1000-R1; optionally with INIRA® |

d = Pitch circle diameter

x = Addendum modification coefficient

A = Distance between pinion axle and rear surface of rack

F_{2T} = Maximum feed force depending on ratio and number of stages

Application-specific dimensioning with cymex® – www.wittenstein-cymex.com

1-stage

greater than 24 (G)
up to 32/38⁴⁾ (I/K)
clamping hub
diameters

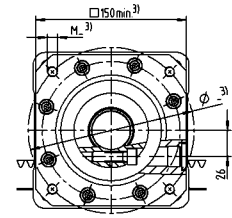
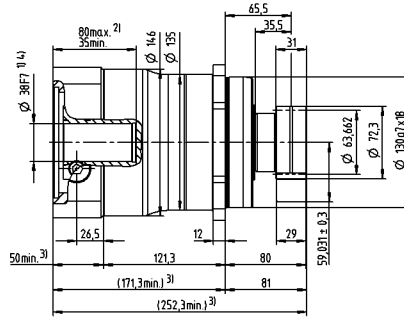
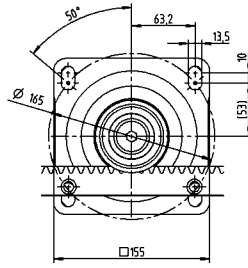

up to 48⁴⁾ (M)
clamping hub
diameters

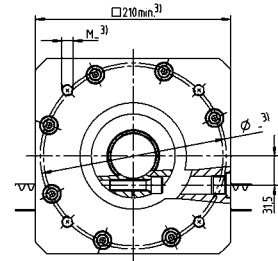
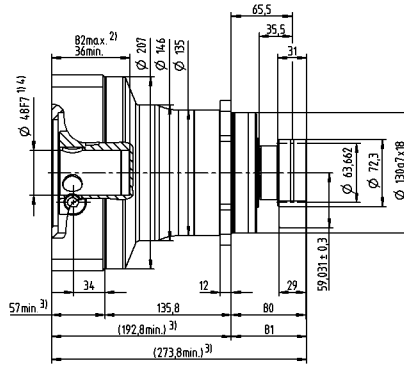
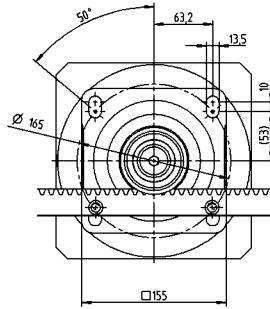

2-stage

greater than 19 (E)
up to 24⁴⁾ (G)
clamping hub
diameters

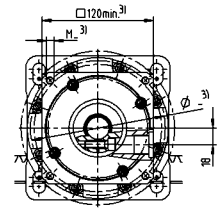
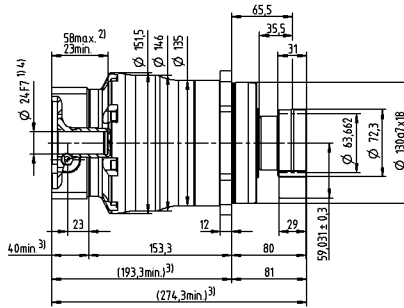
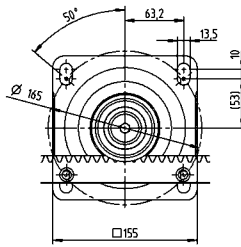

up to 38⁴⁾ (K)
clamping hub
diameters

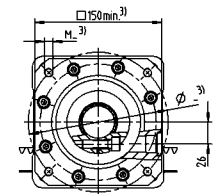
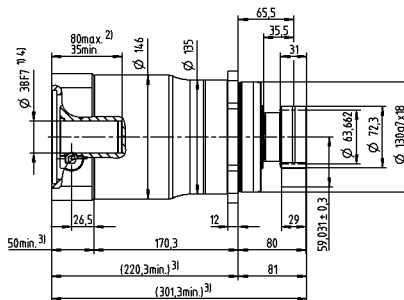
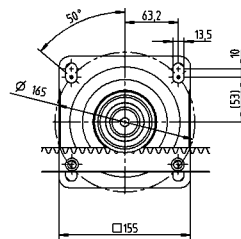

Motor shaft diameter [mm]

Non-tolerated dimensions are nominal dimensions
Detailed rack dimensions starting on page 151

¹⁾ Check motor shaft fit

²⁾ Min./Max. permissible motor shaft length. Longer motor shafts are possible, please contact alpha.

³⁾ The dimensions depend on the motor

⁴⁾ Smaller motor shaft diameter is compensated by a bushing with a minimum thickness of 1 mm

Advanced Linear System ALS 12 with SP+

Planetary gearbox SP+ 180 MF with rack module 4 and pinion RMS module 4

| | | | | |
|---|---|---------------------|---|---|
| System | Max. feed force ¹⁾ F_{2T} | | 12500 N | |
| | Max. feed speed ²⁾ v_{max} | | 400 m/min | 83 m/min |
| Gearbox | No. of stages | | 1 | 2 |
| | Ratios i | | 3 / 4 / 5 / 7 / 8 / 10 | 16 / 20 / 25 / 28 / 32 / 35 / 40 / 50 / 64 / 70 / 100 |
| | Clamping hub diameter | | 38 / 48 / 55 mm | 24 / 32 / 38 / 48 mm |
| | Designation | | SP 180S-MF1-_-_-_-2_-_- | SP 180S-MF2-_-_-_-2_-_- |
| Pinion | Module m | | 4 mm | |
| | Number of teeth z | | 20 | |
| | Pitch circle diameter d | | 84.883 mm | |
| | Profile correction factor x | | 0.4 | |
| | Helix angle β | | -19.5283° (left-handed) | |
| | Designation | | RMS 400-323-20L1-055 | |
| Rack | Module m | | 4 mm | |
| | Lengths L | | 1000 mm (493 mm) | |
| | Helix angle β | | 19.5283° (right-handed) | |
| | Designation | | ZST 400-332-1000-R1; optionally with INIRA® | |
| Lubrication system ³⁾ | Set consisting of lubrication pinion and axis for | Rack | LMT 400-PU -18L1-040-1 | |
| | | Pinion | LMT 400-PU -18R1-040-1 | |
| | Lubricator | 125 cm ³ | LUC+125-0511-02 | |
| | | 400 cm ³ | LUC+400-0511-02 | |
| | Lubricant | | WITTENSTEIN alpha G11 | |

¹⁾ Maximum feed force depending on ratio and number of stages

²⁾ Calculation with lowest ratio and maximum input speed

³⁾ Impulse-controlled basic version with one output and 2 m hose. See page 116 for further information on the lubrication system.
Application-specific dimensioning with cymex® – www.wittenstein-cymex.com

Alternative system solutions

| Pinion | | | Axis distance | SP+ 180S | SK+ 180S | SPC+ 180S | SPK+ 180S | Rack |
|----------------------|-------------|------------|---------------|-----------------|-----------------|-----------------|-----------------|--|
| Designation | d [mm] | x [] | A [mm] | F_{2T} [N] | F_{2T} [N] | F_{2T} [N] | F_{2T} [N] | Designation |
| RMS 400-323-20L1-055 | 84.883 | 0.4 | 79.041 | 12500 | 13100 | 12500 | 12500 | ZST 400-332-1000-R1; optionally with INIRA® |

d = Pitch circle diameter

x = Addendum modification coefficient

A = Distance between pinion axle and rear surface of rack

F_{2T} = Maximum feed force depending on ratio and number of stages

Application-specific dimensioning with cymex® – www.wittenstein-cymex.com

1-stage

greater than 38 (K)
up to 48⁴⁾ (M)
clamping hub
diameters

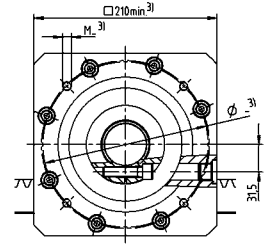
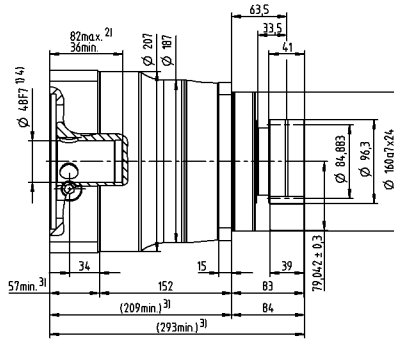
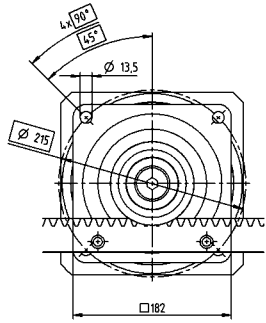

up to 55⁴⁾ (N)
clamping hub
diameters

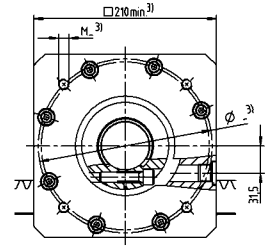
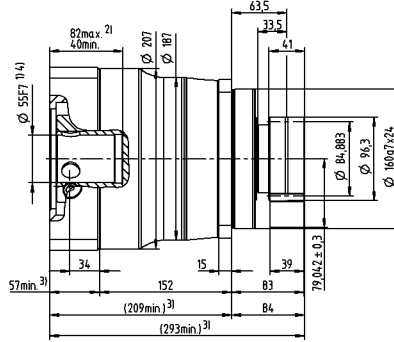
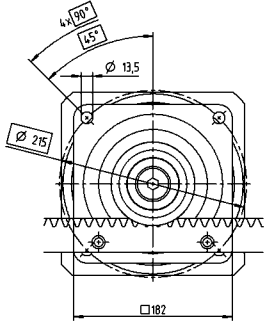

2-stage

greater than 24 (G)
up to 32/38⁴⁾ (I/K)
clamping hub
diameters

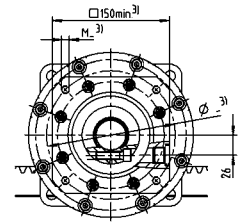
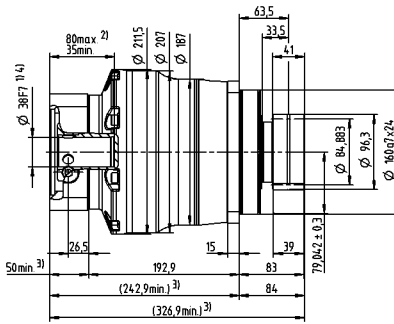
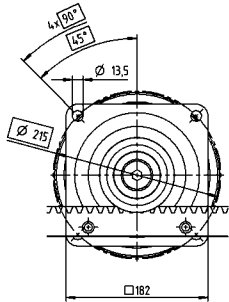

up to 48⁴⁾ (M)
clamping hub
diameters

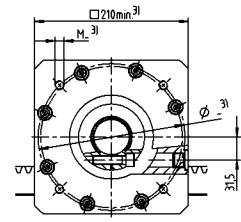
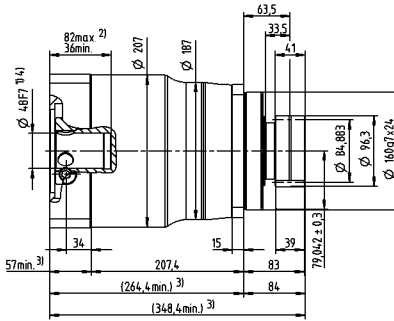
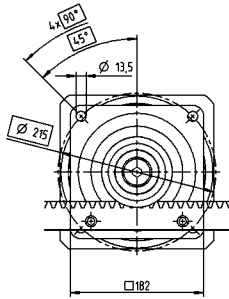

Motor shaft diameter [mm]

Non-tolerated dimensions are nominal dimensions
Detailed rack dimensions starting on page 151
¹⁾ Check motor shaft fit
²⁾ Min./Max. permissible motor shaft length. Longer motor shafts are possible, please contact alpha.
³⁾ The dimensions depend on the motor
⁴⁾ Smaller motor shaft diameter is compensated by a bushing with a minimum thickness of 1 mm

Advanced Linear Systems

Advanced Linear System ALS 1 with TP+

Planetary gearbox TP+ 004 MF with rack module 2 and pinion RMF module 2

| | | | | |
|---|---|---------------------|---|---|
| System | Max. feed force ¹⁾ F_{2T} | | 1370 N | |
| | Max. feed speed ²⁾ v_{max} | | 325 m/min | 81 m/min |
| Gearbox | No. of stages | | 1 | 2 |
| | Ratios i | | 4 / 5 / 7 / 8 / 10 | 16 / 20 / 21 / 25 / 28 / 31 / 32 / 35 / 40 / 50 / 61 / 64 / 70 / 91 / 100 |
| | Clamping hub diameter | | 11 / 14 / 19 mm | 11 / 14 mm |
| | Designation | | TP 004S-MF1-_-_-_-0_-_- | TP 004S-MF2-_-_-_-0_-_- |
| Pinion | Module m | | 2 mm | |
| | Number of teeth z | | 26 | |
| | Pitch circle diameter d | | 55.174 mm | |
| | Profile correction factor x | | 0.4 | |
| | Helix angle β | | -19.5283° (left-handed) | |
| | Designation | | RMF 200-443-26L1-031-8xM5 | |
| Rack | Module m | | 2 mm | |
| | Lengths L | | 1000 mm (500 mm) | |
| | Helix angle β | | 19.5283° (right-handed) | |
| | Designation | | ZST 200-332-1000-R1; optionally with INIRA® | |
| Lubrication system ³⁾ | Set consisting of lubrication pinion and axis for | Rack | LMT 200-PU -18L1-024-1 | |
| | | Pinion | LMT 200-PU -18R1-024-1 | |
| | Lubricator | 125 cm ³ | LUC+125-0511-02 | |
| | | 400 cm ³ | LUC+400-0511-02 | |
| | Lubricant | | WITTENSTEIN alpha G11 | |

¹⁾ Maximum feed force depending on ratio and number of stages

²⁾ Calculation with lowest ratio and maximum input speed

³⁾ Impulse-controlled basic version with one output and 2 m hose. See page 116 for further information on the lubrication system. Application-specific dimensioning with cymex® – www.wittenstein-cymex.com

Alternative system solutions

| Pinion | | | Axis distance | TP+ 004S | PAG 1 | TK+ 004S | TPC+ 004S | Rack |
|---------------------------|-------------|------------|---------------|-----------------|-----------------|-----------------|-----------------|---|
| Designation | d [mm] | x [] | A [mm] | F_{2T} [N] | F_{2T} [N] | F_{2T} [N] | F_{2T} [N] | Designation |
| RMF 200-443-26L1-031-8xM5 | 55.174 | 0.4 | 50.387 | 1370 | 1370 | 1080 | 1370 | ZST 200-332-1000-R1; optionally with INIRA® |

d = Pitch circle diameter

x = Addendum modification coefficient

A = Distance between pinion axle and rear surface of rack

F_{2T} = Maximum feed force depending on ratio and number of stages

Application-specific dimensioning with cymex® – www.wittenstein-cymex.com

1-stage

greater than 11 ⁴⁾ (B) up to 14 ⁴⁾ (C) clamping hub diameters

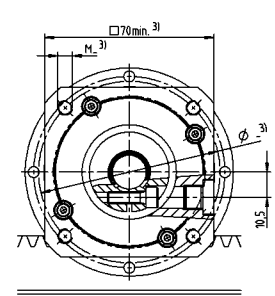
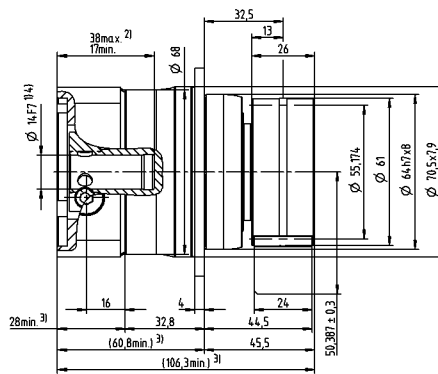
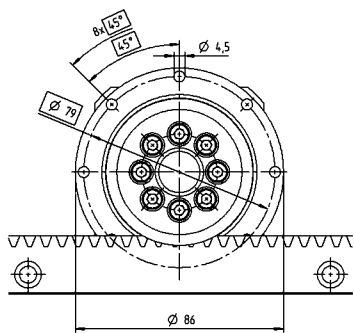

up to 19 ⁴⁾ (E) clamping hub diameters

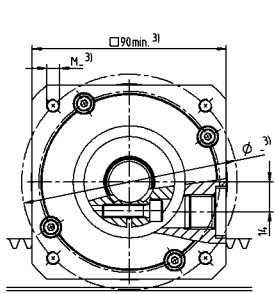
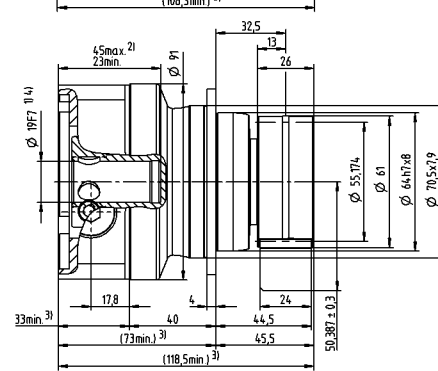
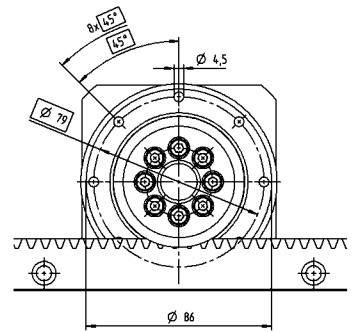

2-stage

up to 11 ⁴⁾ (B) clamping hub diameters

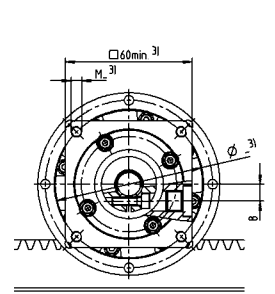
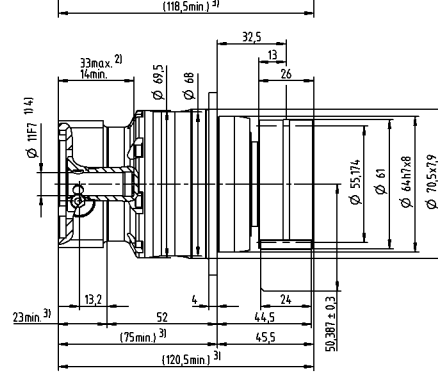
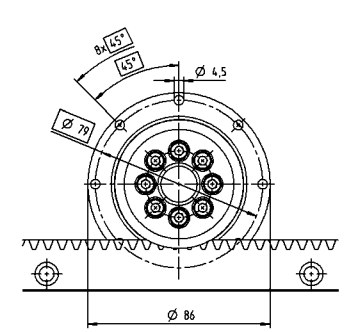

up to 14 ⁴⁾ (C) clamping hub diameters

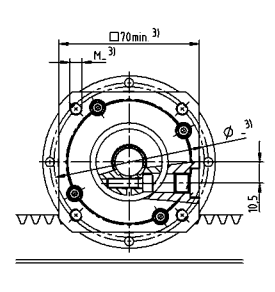
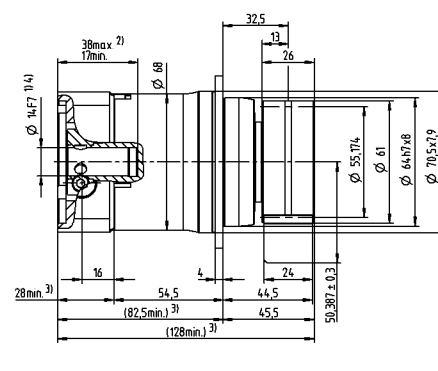
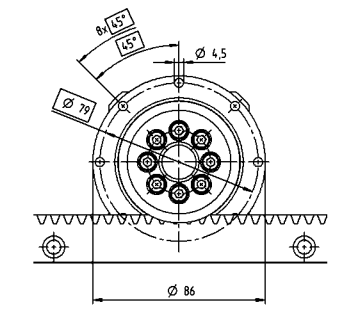

Motor shaft diameter [mm]

Non-tolerated dimensions are nominal dimensions
 Detailed rack dimensions starting on page 151
¹⁾ Check motor shaft fit
²⁾ Min./Max. permissible motor shaft length. Longer motor shafts are possible, please contact alpha.
³⁾ The dimensions depend on the motor
⁴⁾ Smaller motor shaft diameter is compensated by a bushing with a minimum thickness of 1 mm

Advanced Linear System ALS 2 with TP+

Planetary gearbox TP+ 010 MF with rack module 2 and pinion RMF module 2

| | | | | |
|---|---|---------------------|---|---|
| System | Max. feed force ¹⁾ F_{2T} | | 2500 N | |
| | Max. feed speed ²⁾ v_{max} | | 412 m/min | 103 m/min |
| Gearbox | No. of stages | | 1 | 2 |
| | Ratios i | | 4 / 5 / 7 / 8 / 10 | 16 / 20 / 21 / 25 / 28 / 31 / 32 / 35 / 40 / 50 / 61 / 64 / 70 / 91 / 100 |
| | Clamping hub diameter | | 14 / 19 / 24 mm | 11 / 14 / 19 mm |
| | Designation | | TP 010S-MF1-_-_-_-0_-_- | TP 010S-MF2-_-_-_-0_-_- |
| Pinion | Module m | | 2 mm | |
| | Number of teeth z | | 33 | |
| | Pitch circle diameter d | | 70.028 mm | |
| | Profile correction factor x | | 0.3 | |
| | Helix angle β | | -19.5283° (left-handed) | |
| | Designation | | RMF 200-443-33L1-050-8xM6 | |
| Rack | Module m | | 2 mm | |
| | Lengths L | | 1000 mm (500 mm) | |
| | Helix angle β | | 19.5283° (right-handed) | |
| | Designation | | ZST 200-332-1000-R1; optionally with INIRA® | |
| Lubrication system ³⁾ | Set consisting of lubrication pinion and axis for | Rack | LMT 200-PU -18L1-024-1 | |
| | | Pinion | LMT 200-PU -18R1-024-1 | |
| | Lubricator | 125 cm ³ | LUC+125-0511-02 | |
| | | 400 cm ³ | LUC+400-0511-02 | |
| | Lubricant | | WITTENSTEIN alpha G11 | |

¹⁾ Maximum feed force depending on ratio and number of stages

²⁾ Calculation with lowest ratio and maximum input speed

³⁾ Impulse-controlled basic version with one output and 2 m hose. See page 116 for further information on the lubrication system. Application-specific dimensioning with cymex® – www.wittenstein-cymex.com

Alternative system solutions

| Pinion | | | Axis distance | TP+ 010S | PAG 2 | TK+ 010S | TPK+ 010S | TPC+ 010S | Rack |
|---------------------------|-------------|------------|---------------|-----------------|-----------------|-----------------|-----------------|-----------------|---|
| Designation | d [mm] | x [] | A [mm] | F_{2T} [N] | F_{2T} [N] | F_{2T} [N] | F_{2T} [N] | F_{2T} [N] | Designation |
| RMF 200-443-29L1-050-8xM6 | 61.540 | 0.3 | 53.370 | 2280 | 2280 | 2260 | 2280 | 2280 | ZST 200-332-1000-R1; optionally with INIRA® |
| RMF 200-443-33L1-050-8xM6 | 70.028 | 0.3 | 57.614 | 2490 | 2490 | 1990 | 2490 | 2490 | ZST 200-332-1000-R1; optionally with INIRA® |
| RMF 200-443-37L1-050-8xM6 | 78.517 | 0.3 | 61.858 | 2480 | 2480 | 1770 | 2480 | 2480 | ZST 200-332-1000-R1; optionally with INIRA® |
| RMW 200-444-20L1-037 | 42.441 | 0.4 | 44.021 | 2290 | 2290 | - | 2290 | 2290 | ZST 200-332-1000-R1; optionally with INIRA® |

d = Pitch circle diameter

x = Addendum modification coefficient

A = Distance between pinion axle and rear surface of rack

F_{2T} = Maximum feed force depending on ratio and number of stages

Application-specific dimensioning with cymex® – www.wittenstein-cymex.com

1-stage

greater than 14 (C) up to 19⁴⁾ (E) clamping hub diameters

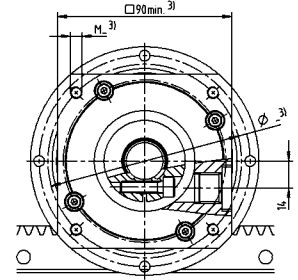
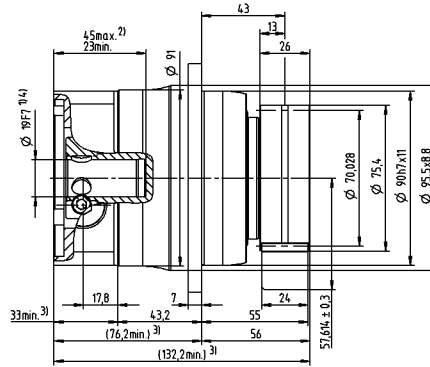
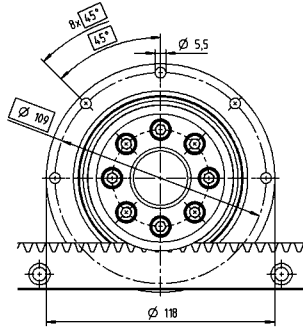

up to 24⁴⁾ (G) clamping hub diameters

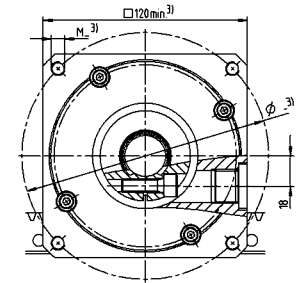
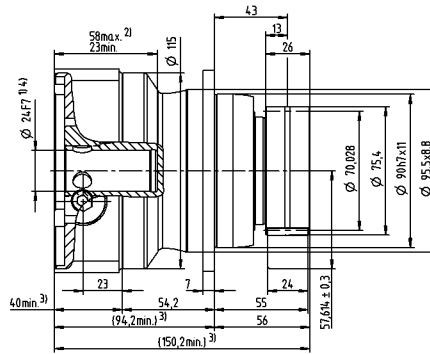
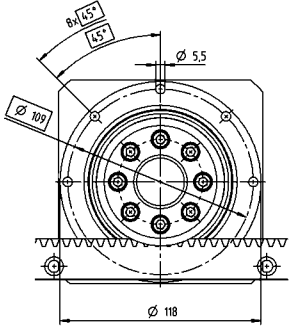

2-stage

greater than 11 (B) up to 14⁴⁾ (C) clamping hub diameters

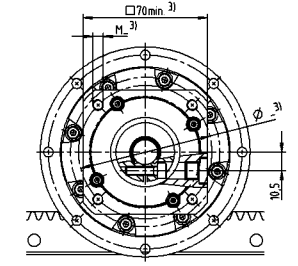
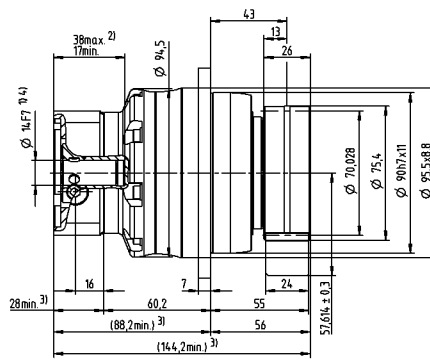
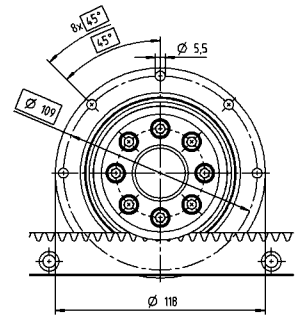

up to 19⁴⁾ (E) clamping hub diameters

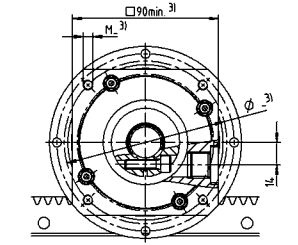
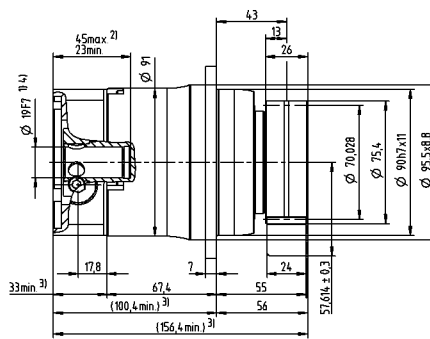
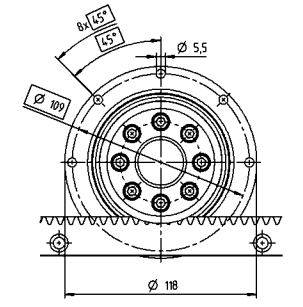

Motor shaft diameter [mm]

Non-tolerated dimensions are nominal dimensions
 Detailed rack dimensions starting on page 151
¹⁾ Check motor shaft fit
²⁾ Min./Max. permissible motor shaft length. Longer motor shafts are possible, please contact alpha.
³⁾ The dimensions depend on the motor
⁴⁾ Smaller motor shaft diameter is compensated by a bushing with a minimum thickness of 1 mm

Advanced Linear Systems

Advanced Linear System ALS 3 with TP+

Planetary gearbox TP+ 025 MF with rack module 2 and pinion RMF module 2

| | | | | |
|---|---|---------------------|---|---|
| System | Max. feed force ¹⁾ F_{2T} | | 3600 N | |
| | Max. feed speed ²⁾ v_{max} | | 367 m/min | 125 m/min |
| Gearbox | No. of stages | | 1 | 2 |
| | Ratios i | | 4 / 5 / 7 / 8 / 10 | 16 / 20 / 21 / 25 / 28 / 31 / 32 / 35 / 40 / 50 / 61 / 64 / 70 / 91 / 100 |
| | Clamping hub diameter | | 19 / 24 / 28 / 38 mm | 14 / 19 / 24 mm |
| | Designation | | TP 025S-MF1-_-_-_-0_-_- | TP 025S-MF2-_-_-_-0_-_- |
| Pinion | Module m | | 2 mm | |
| | Number of teeth z | | 40 | |
| | Pitch circle diameter d | | 84.883 mm | |
| | Profile correction factor x | | 0.3 | |
| | Helix angle β | | -19.5283° (left-handed) | |
| | Designation | | RMF 200-443-40L1-063-12xM6 | |
| Rack | Module m | | 2 mm | |
| | Lengths L | | 1000 mm (500 mm) | |
| | Helix angle β | | 19.5283° (right-handed) | |
| | Designation | | ZST 200-332-1000-R1; optionally with INIRA® | |
| Lubrication system ³⁾ | Set consisting of lubrication pinion and axis for | Rack | LMT 200-PU -18L1-024-1 | |
| | | Pinion | LMT 200-PU -18R1-024-1 | |
| | Lubricator | 125 cm ³ | LUC+125-0511-02 | |
| | | 400 cm ³ | LUC+400-0511-02 | |
| | Lubricant | | WITTENSTEIN alpha G11 | |

¹⁾ Maximum feed force depending on ratio and number of stages

²⁾ Calculation with lowest ratio and maximum input speed

³⁾ Impulse-controlled basic version with one output and 2 m hose. See page 116 for further information on the lubrication system. Application-specific dimensioning with cymex® – www.wittenstein-cymex.com

Alternative system solutions

| Pinion | | | Axis distance | TP+ 025S | PAG 3 | TK+ 025S | TPK+ 025S | TPC+ 025S | Rack |
|----------------------------|----------|---------|---------------|--------------|--------------|--------------|--------------|--------------|---|
| Designation | d [mm] | x [] | A [mm] | F_{2T} [N] | F_{2T} [N] | F_{2T} [N] | F_{2T} [N] | F_{2T} [N] | Designation |
| RMF 200-443-35L1-063-12xM6 | 74.272 | 0.3 | 59.736 | 3330 | 3330 | 4300 | 3330 | 3330 | ZST 200-332-1000-R1; optionally with INIRA® |
| RMF 200-443-40L1-063-12xM6 | 84.883 | 0.3 | 65.041 | 3600 | 3600 | 3990 | 3600 | 3600 | ZST 200-332-1000-R1; optionally with INIRA® |
| RMF 200-443-45L1-063-12xM6 | 95.493 | 0.22 | 70.187 | 3580 | 3580 | 3540 | 3580 | 3580 | ZST 200-332-1000-R1; optionally with INIRA® |
| RMW 200-444-20L1-037 | 42.441 | 0.4 | 44.021 | 3370 | 3370 | - | 3370 | 3370 | ZST 200-332-1000-R1; optionally with INIRA® |
| RMW 300-444-20L1-055 | 63.662 | 0.4 | 59.031 | 3220 | 3220 | - | 3220 | 3220 | ZST 300-332-1000-R1; optionally with INIRA® |

d = Pitch circle diameter

x = Addendum modification coefficient

A = Distance between pinion axle and rear surface of rack

F_{2T} = Maximum feed force depending on ratio and number of stages

Application-specific dimensioning with cymex® – www.wittenstein-cymex.com

1-stage

greater than 19 (E)
up to 24/28⁴⁾ (G/H)
clamping hub
diameters

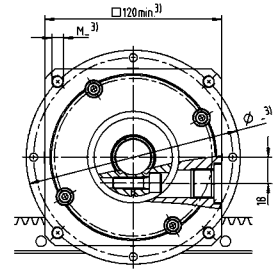
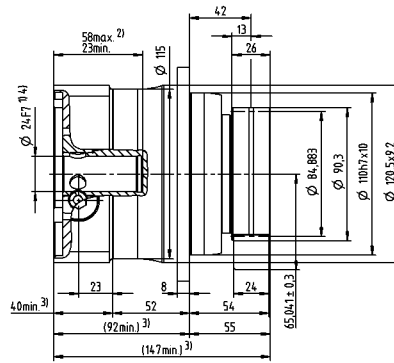
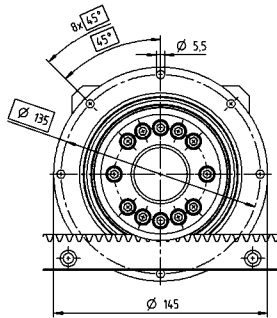

up to 38⁴⁾ (K)
clamping hub
diameters

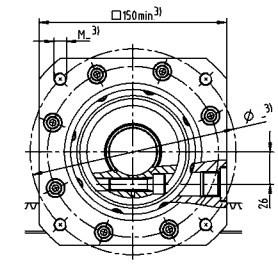
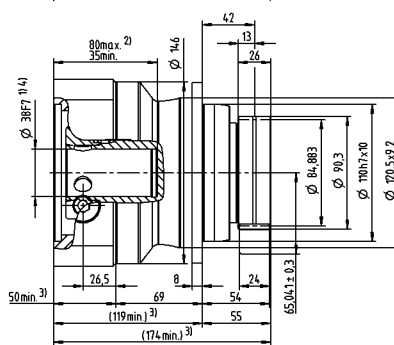
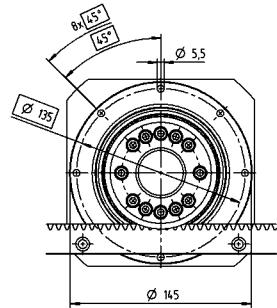

2-stage

greater than 14 (C)
up to 19⁴⁾ (E)
clamping hub
diameters

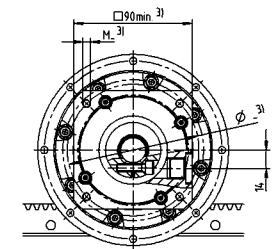
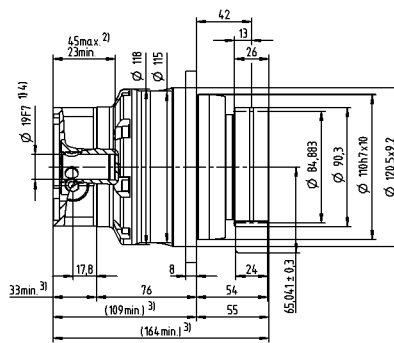
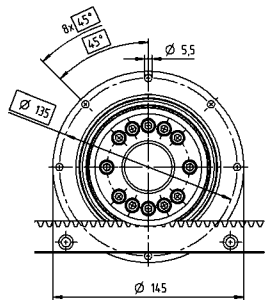

up to 24/28⁴⁾ (G/H)
clamping hub
diameters

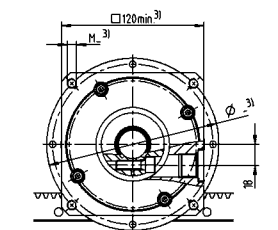
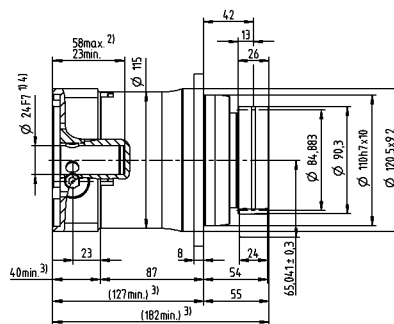
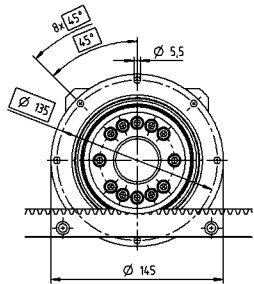

Motor shaft diameter [mm]

Non-tolerated dimensions are nominal dimensions
Detailed rack dimensions starting on page 151

- ¹⁾ Check motor shaft fit
- ²⁾ Min./Max. permissible motor shaft length. Longer motor shafts are possible, please contact alpha.
- ³⁾ The dimensions depend on the motor
- ⁴⁾ Smaller motor shaft diameter is compensated by a bushing with a minimum thickness of 1 mm

Advanced Linear System ALS 12 with TP+

Planetary gearbox TP+ 050 MF with rack module 3 and pinion RMF module 3

| | | | | |
|---|---|---------------------|---|---|
| System | Max. feed force ¹⁾ F_{2T} | | 11800 N | |
| | Max. feed speed ²⁾ v_{max} | | 438 m/min | 137 m/min |
| Gearbox | No. of stages | | 1 | 2 |
| | Ratios i | | 4 / 5 / 7 / 8 / 10 | 16 / 20 / 21 / 25 / 28 / 31 / 32 / 35 / 40 / 50 / 61 / 64 / 70 / 91 / 100 |
| | Clamping hub diameter | | 24 / 32 / 38 / 48 mm | 19 / 24 / 38 mm |
| | Designation | | TP 050S-MF1-_-_-_-0_- | TP 050S-MF2-_-_-_-0_- |
| Pinion | Module m | | 3 mm | |
| | Number of teeth z | | 35 | |
| | Pitch circle diameter d | | 111.409 mm | |
| | Profile correction factor x | | 0.3 | |
| | Helix angle β | | -19.5283° (left-handed) | |
| | Designation | | RMF 300-443-35L1-080-12xM8 | |
| Rack | Module m | | 3 | |
| | Lengths L | | 1000 mm (500 mm) | |
| | Helix angle β | | 19.5283° (right-handed) | |
| | Designation | | ZST 300-333-1000-R1; optionally with INIRA® | |
| Lubrication system ³⁾ | Set consisting of lubrication pinion and axis for | Rack | LMT 300-PU -18L1-030-1 | |
| | | Pinion | LMT 300-PU -18R1-030-1 | |
| | Lubricator | 125 cm ³ | LUC+125-0511-02 | |
| | | 400 cm ³ | LUC+400-0511-02 | |
| | Lubricant | | WITTENSTEIN alpha G11 | |

¹⁾ Maximum feed force depending on ratio and number of stages

²⁾ Calculation with lowest ratio and maximum input speed

³⁾ Impulse-controlled basic version with one output and 2 m hose. See page 116 for further information on the lubrication system. Application-specific dimensioning with cymex® – www.wittenstein-cymex.com

Alternative system solutions

| Pinion | | | Axis distance | TP+ 050S | TK+ 050S | TPK+ 050S | TPC+ 050S | Rack |
|----------------------------|-------------|------------|---------------|-----------------|-----------------|-----------------|-----------------|---|
| Designation | d [mm] | x [] | A [mm] | F_{2T} [N] | F_{2T} [N] | F_{2T} [N] | F_{2T} [N] | Designation |
| RMF 300-443-31L1-080-12xM8 | 98.676 | 0.3 | 76.238 | 10600 | 6050 | 10600 | 10600 | ZST 300-333-1000-R1; optionally with INIRA® |
| RMF 300-443-35L1-080-12xM8 | 111.409 | 0.3 | 82.604 | 11800 | 5350 | 11800 | 11800 | ZST 300-333-1000-R1; optionally with INIRA® |
| RMF 300-443-40L1-080-12xM8 | 127.324 | 0.3 | 90.562 | 11100 | 4700 | 11100 | 10900 | ZST 300-333-1000-R1; optionally with INIRA® |
| RMW 300-444-20L1-055 | 63.662 | 0.4 | 59.031 | 10900 | - | 10900 | 10900 | ZST 300-333-1000-R1; optionally with INIRA® |
| RMW 400-444-20L1-073 | 84.882 | 0.2 | 78.241 | 10300 | - | 10300 | 10300 | ZST 400-332-1000-R1; optionally with INIRA® |

d = Pitch circle diameter

x = Addendum modification coefficient

A = Distance between pinion axle and rear surface of rack

F_{2T} = Maximum feed force depending on ratio and number of stages

Application-specific dimensioning with cymex® – www.wittenstein-cymex.com

1-stage

greater than 24 (G)
up to 32/38⁴⁾ (I/K)
clamping hub
diameters

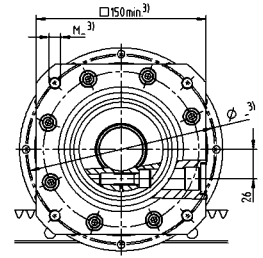
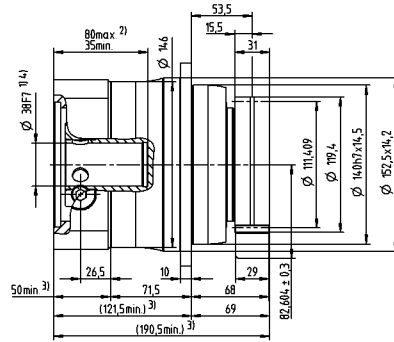
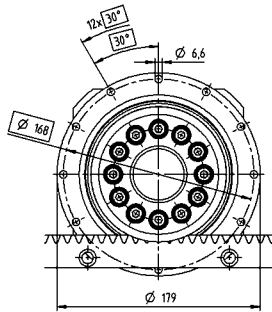

up to 48⁴⁾ (M)
clamping hub
diameters

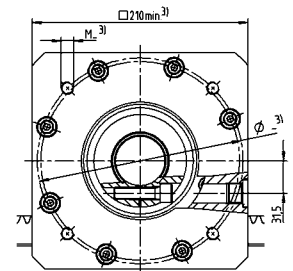
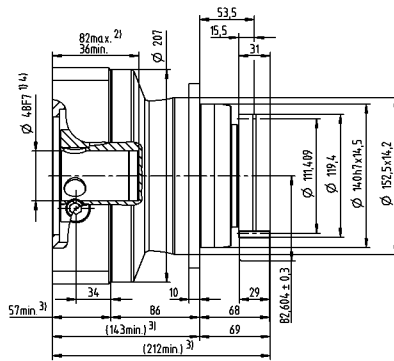
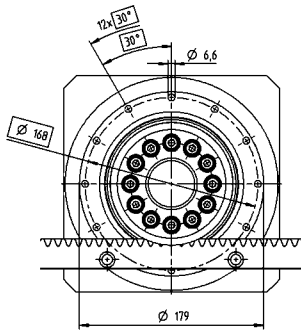

2-stage

greater than 19 (E)
up to 24⁴⁾ (G)
clamping hub
diameters

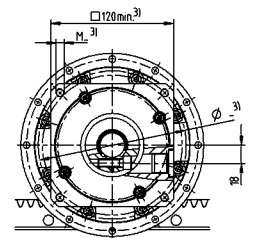
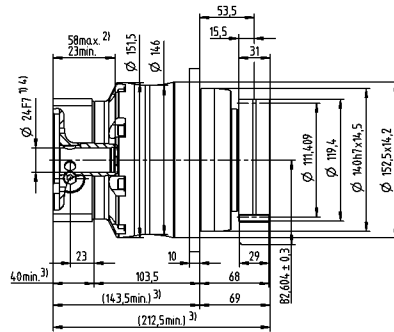
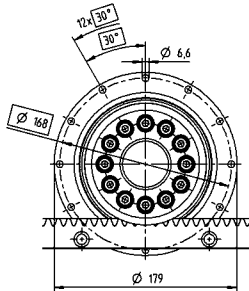

up to 38⁴⁾ (K)
clamping hub
diameters

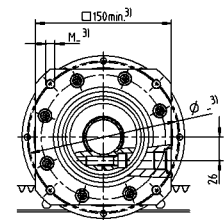
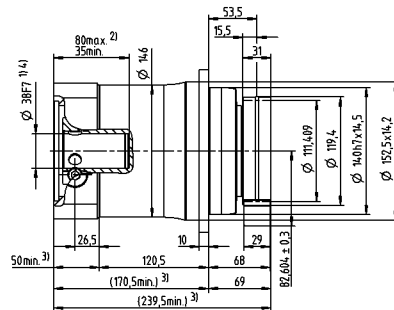
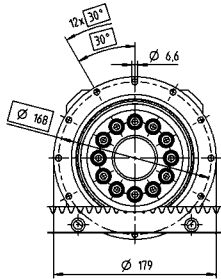

Motor shaft diameter [mm]

Non-tolerated dimensions are nominal dimensions
Detailed rack dimensions starting on page 151

¹⁾ Check motor shaft fit

²⁾ Min./Max. permissible motor shaft length. Longer motor shafts are possible, please contact alpha.

³⁾ The dimensions depend on the motor

⁴⁾ Smaller motor shaft diameter is compensated by a bushing with a minimum thickness of 1 mm

Advanced Linear System ALS 20 with TP+

Planetary gearbox TP+ 110 MF with rack module 4 and pinion RMF module 4

| | | | | |
|---|---|---------------------|--|---|
| System | Max. feed force ¹⁾ F_{2T} | | 19700 N | |
| | Max. feed speed ²⁾ v_{max} | | 570 m/min | 178 m/min |
| Gearbox | No. of stages | | 1 | 2 |
| | Ratios i | | 4 / 5 / 7 / 8 / 10 | 16 / 20 / 21 / 25 / 28 / 31 / 32 / 35 / 40 / 50 / 61 / 64 / 70 / 91 / 100 |
| | Clamping hub diameter | | 38 / 48 / 55 mm | 24 / 32 / 38 / 48 mm |
| | Designation | | TP 110S-MF1-_-_-_-0_-_- | TP 110S-MF2-_-_-_-0_-_- |
| Pinion | Module m | | 4 mm | |
| | Number of teeth z | | 38 | |
| | Pitch circle diameter d | | 161.277 mm | |
| | Profile correction factor x | | 0.25 | |
| | Helix angle β | | -19.5283° (left-handed) | |
| | Designation | | RMF 400-443-38L1-125-12xM10 | |
| Rack | Module m | | 4 mm | |
| | Lengths L | | 1000 mm (493 mm) | |
| | Helix angle β | | 19.5283° (right-handed) | |
| | Designation | | ZST 400-334-1000-R11; optionally with INIRA® | |
| Lubrication system ³⁾ | Set consisting of lubrication pinion and axis for | Rack | LMT 400-PU -18L1-040-1 | |
| | | Pinion | LMT 400-PU -18R1-040-1 | |
| | Lubricator | 125 cm ³ | LUC+125-0511-02 | |
| | | 400 cm ³ | LUC+400-0511-02 | |
| | Lubricant | | WITTENSTEIN alpha G11 | |

¹⁾ Maximum feed force depending on ratio and number of stages

²⁾ Calculation with lowest ratio and maximum input speed

³⁾ Impulse-controlled basic version with one output and 2 m hose. See page 116 for further information on the lubrication system.

Application-specific dimensioning with cymex® – www.wittenstein-cymex.com

Alternative system solutions

| Pinion | | | Axis distance | TP+ 110S | TK+ 0110S | TPK+ 110S | TPC+ 110S | Rack |
|-----------------------------|-------------|------------|---------------|-----------------|-----------------|-----------------|-----------------|--|
| Designation | d [mm] | x [] | A [mm] | F_{2T} [N] | F_{2T} [N] | F_{2T} [N] | F_{2T} [N] | Designation |
| RMF 400-443-38L1-125-12xM10 | 161.277 | 0.25 | 116.639 | 19700 | 7900 | 19700 | 19700 | ZST 400-334-1000-R11; optionally with INIRA® |
| RMW 400-444-20L1-073 | 84.882 | 0.2 | 78.241 | 20900 | – | 20900 | 20900 | ZST 400-334-1000-R11; optionally with INIRA® |
| RMW 500-444-19L1-089 | 100.798 | 0.4 | 86.399 | 20100 | – | 20100 | 20100 | ZST 500-332-1000-R1; optionally with INIRA® |

d = Pitch circle diameter

x = Addendum modification coefficient

A = Distance between pinion axle and rear surface of rack

F_{2T} = Maximum feed force depending on ratio and number of stages

Application-specific dimensioning with cymex® – www.wittenstein-cymex.com

1-stage

greater than 38 (K)
up to 48⁴⁾ (M)
clamping hub
diameters

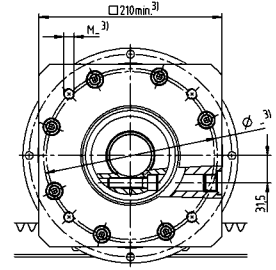
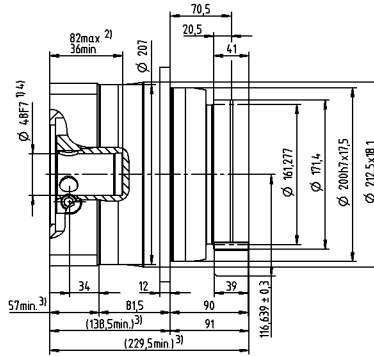
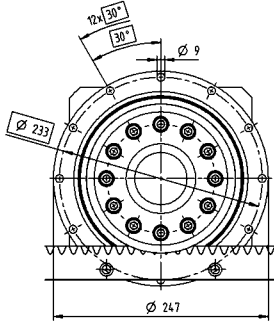

up to 55⁴⁾ (N)
clamping hub
diameters

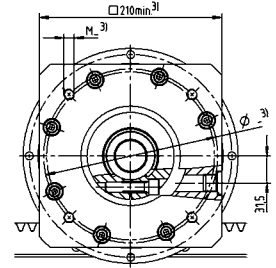
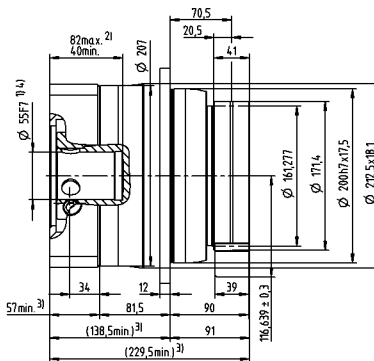
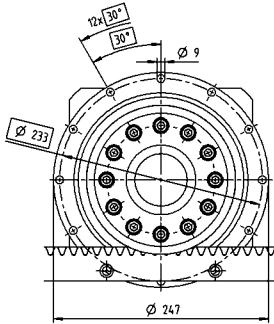

2-stage

greater than 24 (G)
up to 32/38⁴⁾ (I/K)
clamping hub
diameters

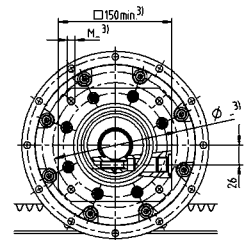
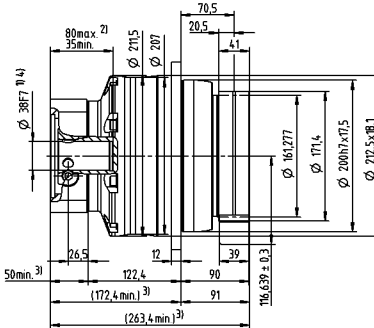
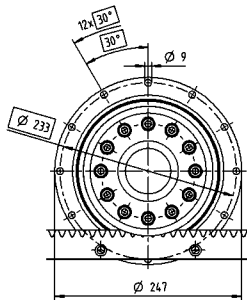

up to 48⁴⁾ (M)
clamping hub
diameters

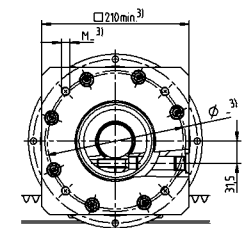
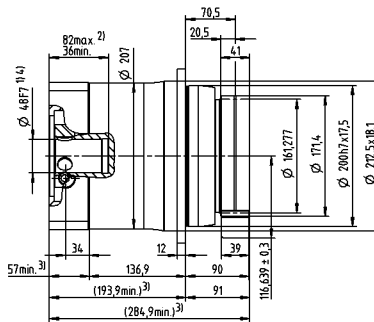
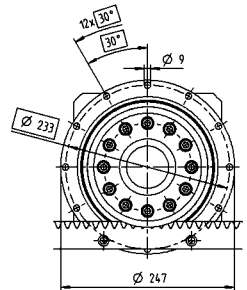

Motor shaft diameter [mm]

Non-olerated dimensions are nominal dimensions
Detailed rack dimensions starting on page 151

- ¹⁾ Check motor shaft fit
- ²⁾ Min./Max. permissible motor shaft length. Longer motor shafts are possible, please contact alpha.
- ³⁾ The dimensions depend on the motor
- ⁴⁾ Smaller motor shaft diameter is compensated by a bushing with a minimum thickness of 1 mm

Advanced Linear System ALS 4 with TP+ MA

Planetary gearbox TP+ 025 MA with rack module 2 and pinion RMW module 2

| | | | | |
|---|---|---------------------|---|---------------------------|
| System | Max. feed force ¹⁾ F_{zT} | | 4200 N | |
| | Max. feed speed ²⁾ v_{max} | | 45 m/min | 15 m/min |
| Gearbox | No. of stages | | 2 | 3 |
| | Ratios i | | 22 / 27.5 / 38.5 / 55 | 66 / 88 / 110 / 154 / 220 |
| | Clamping hub diameter | | 19 / 24 mm | 19 mm |
| | Designation | | TP 025S-MA2-_-_-_-3_-_- | TP 025S-MA3-_-_-_-3_-_- |
| Pinion | Module m | | 2 mm | |
| | Number of teeth z | | 20 | |
| | Pitch circle diameter d | | 42.441 mm | |
| | Profile correction factor x | | 0.4 | |
| | Helix angle β | | -19.5283° (left-handed) | |
| | Designation | | RMW 200-444-20L1-037 | |
| Rack | Module m | | 2 mm | |
| | Lengths L | | 1000 mm (500 mm) | |
| | Helix angle β | | 19.5283° (right-handed) | |
| | Designation | | ZST 200-332-1000-R1; optionally with INIRA® | |
| Lubrication system ³⁾ | Set consisting of lubrication pinion and axis for | Rack | LMT 200-PU -18L1-024-1 | |
| | | Pinion | LMT 200-PU -18R1-024-1 | |
| | Lubricator | 125 cm ³ | LUC+125-0511-02 | |
| | | 400 cm ³ | LUC+400-0511-02 | |
| | Lubricant | | WITTENSTEIN alpha G11 | |

¹⁾ Maximum feed force depending on ratio and number of stages

²⁾ Calculation with lowest ratio and maximum input speed

³⁾ Impulse-controlled basic version with one output and 2 m hose. See page 116 for further information on the lubrication system.
Application-specific dimensioning with cymex® – www.wittenstein-cymex.com

Alternative system solutions

| Pinion | | | Axis distance | TP+ 025S HIGH TORQUE | TPM+ 025 HIGH TORQUE | TPK+ 025S HIGH TORQUE | Rack |
|----------------------------|-------------|------------|---------------|-------------------------|-------------------------|--------------------------|--|
| Designation | d [mm] | x [] | A [mm] | F_{zT} [N] | F_{zT} [N] | F_{zT} [N] | Designation |
| RMW 200-444-20L1-037 | 42.441 | 0.4 | 44.021 | 4200 | 4200 | 4200 | ZST 200-332-1000-R1; optionally with INIRA® |
| RMW 300-444-20L1-055 | 63.662 | 0.4 | 59.031 | 4050 | 4050 | 4050 | ZST 300-332-1000-R1; optionally with INIRA® |
| RMF 200-443-40L1-063-12xM8 | 84.883 | 0.3 | 65.041 | 4500 | 4500 | 4500 | ZST 200-333-1000-R1; optionally with INIRA® |

d = Pitch circle diameter

x = Addendum modification coefficient

A = Distance between pinion axle and rear surface of rack

F_{zT} = Maximum feed force depending on ratio and number of stages

Application-specific dimensioning with cymex® – www.wittenstein-cymex.com

2-stage

up to 19⁴⁾ (E)
clamping hub
diameters

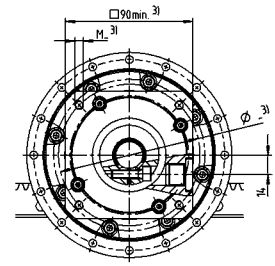
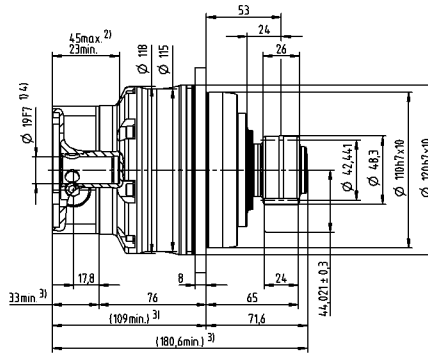
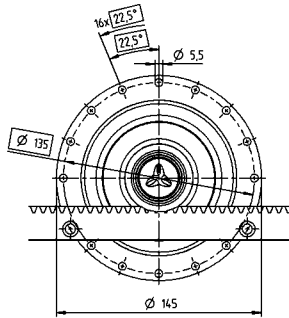

up to 24⁴⁾ (G)
clamping hub
diameters

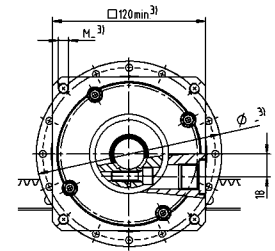
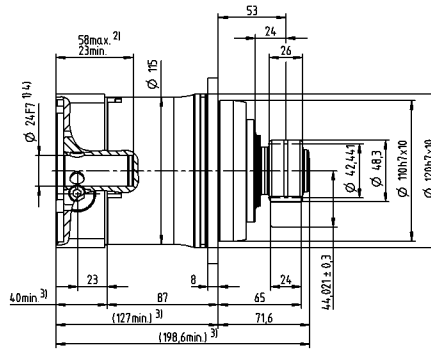
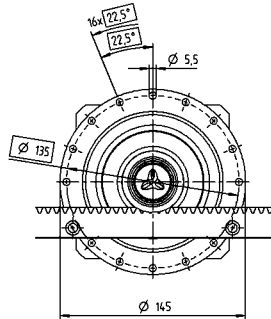

3-stage

up to 19⁴⁾ (E)
clamping hub
diameters

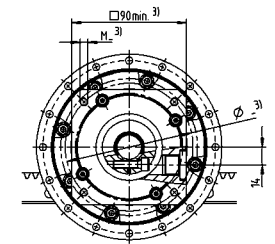
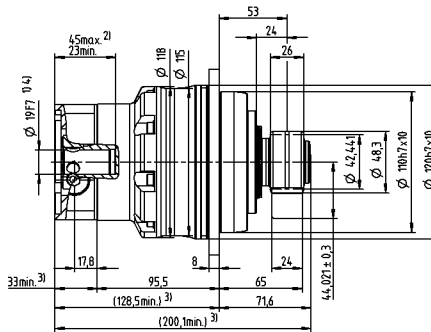
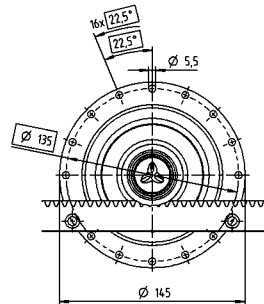

Motor shaft diameter [mm]

Non-tolerated dimensions are nominal dimensions
Detailed rack dimensions starting on page 151

- ¹⁾ Check motor shaft fit
- ²⁾ Min./Max. permissible motor shaft length. Longer motor shafts are possible, please contact alpha.
- ³⁾ The dimensions depend on the motor
- ⁴⁾ Smaller motor shaft diameter is compensated by a bushing with a minimum thickness of 1 mm

Advanced Linear System ALS 11 with TP+ MA

Planetary gearbox TP+ 050 MA with rack module 3 and pinion RMW module 3

| | | | | |
|---|---|---------------------|---|---------------------------|
| System | Max. feed force ¹⁾ F_{2T} | | 10900 N | |
| | Max. feed speed ²⁾ v_{max} | | 57 m/min | 19 m/min |
| Gearbox | No. of stages | | 2 | 3 |
| | Ratios i | | 22 / 27.5 / 38.5 / 55 | 66 / 88 / 110 / 154 / 220 |
| | Clamping hub diameter | | 24 / 38 mm | 24 mm |
| | Designation | | TP 050S-MA2-_-_-_-3_-_- | TP 050S-MA3-_-_-_-3_-_- |
| Pinion | Module m | | 3 mm | |
| | Number of teeth z | | 20 | |
| | Pitch circle diameter d | | 63.662 mm | |
| | Profile correction factor x | | 0.4 | |
| | Helix angle β | | -19.5283° (left-handed) | |
| | Designation | | RMW 300-444-20L1-055 | |
| Rack | Module m | | 3 mm | |
| | Lengths L | | 1000 mm (500 mm) | |
| | Helix angle β | | 19.5283° (right-handed) | |
| | Designation | | ZST 300-333-1000-R1; optionally with INIRA® | |
| Lubrication system ³⁾ | Set consisting of lubrication pinion and axis for | Rack | LMT 300-PU -18L1-030-1 | |
| | | Pinion | LMT 300-PU -18R1-030-1 | |
| | Lubricator | 125 cm ³ | LUC+125-0511-02 | |
| | | 400 cm ³ | LUC+400-0511-02 | |
| | Lubricant | | WITTENSTEIN alpha G11 | |

¹⁾ Maximum feed force depending on ratio and number of stages

²⁾ Calculation with lowest ratio and maximum input speed

³⁾ Impulse-controlled basic version with one output and 2 m hose. See page 116 for further information on the lubrication system. Application-specific dimensioning with cymex® – www.wittenstein-cymex.com

Alternative system solutions

| Pinion | | | Axis distance | TP+ 050S HIGH TORQUE | TPM+ 050 HIGH TORQUE | TPK+ 050S HIGH TORQUE | Rack |
|-----------------------------|-------------|------------|---------------|-------------------------|-------------------------|--------------------------|--|
| Designation | d [mm] | x [] | A [mm] | F_{2T} [N] | F_{2T} [N] | F_{2T} [N] | Designation |
| RMW 300-444-20L1-055 | 63.662 | 0.4 | 59.031 | 10900 | 10900 | 10900 | ZST 300-333-1000-R1; optionally with INIRA® |
| RMW 400-444-20L1-073 | 84.882 | 0.2 | 78.241 | 10300 | 10300 | 10300 | ZST 400-332-1000-R1; optionally with INIRA® |
| RMF 300-443-35L1-080-12xM10 | 111.409 | 0.3 | 82.604 | 11800 | 11800 | 11800 | ZST 300-333-1000-R1; optionally with INIRA® |
| RMF 300-443-40L1-080-12xM10 | 127.324 | 0.3 | 90.562 | 11700 | 11700 | 11700 | ZST 300-333-1000-R1; optionally with INIRA® |

d = Pitch circle diameter

x = Addendum modification coefficient

A = Distance between pinion axle and rear surface of rack

F_{2T} = Maximum feed force depending on ratio and number of stages

Application-specific dimensioning with cymex® – www.wittenstein-cymex.com

2-stage

up to 24⁴⁾ (G)
clamping hub
diameters

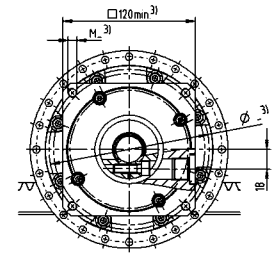
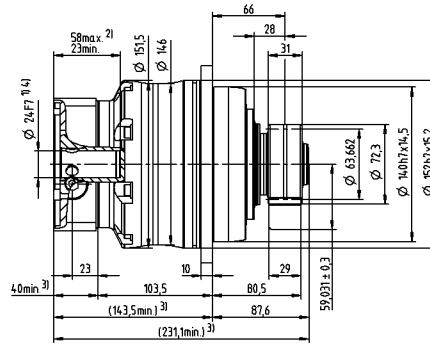
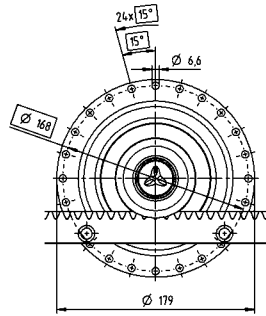

up to 38⁴⁾ (K)
clamping hub
diameters

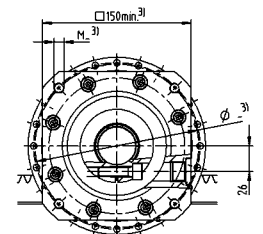
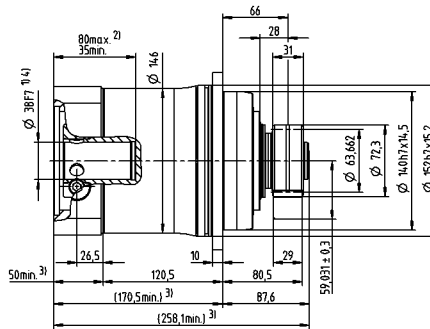
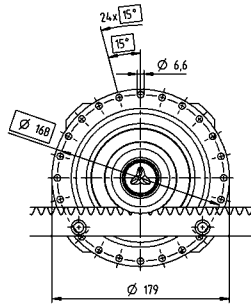

3-stage

up to 24⁴⁾ (G)
clamping hub
diameters

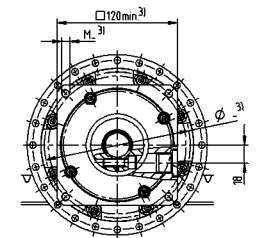
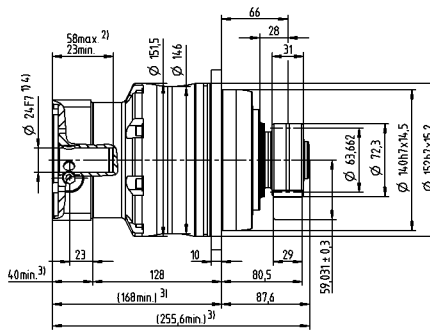
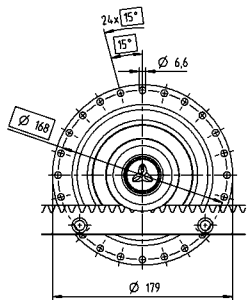

Motor shaft diameter [mm]

Non-tolerated dimensions are nominal dimensions
Detailed rack dimensions starting on page 151

¹⁾ Check motor shaft fit

²⁾ Min./Max. permissible motor shaft length. Longer motor shafts are possible, please contact alpha.

³⁾ The dimensions depend on the motor

⁴⁾ Smaller motor shaft diameter is compensated by a bushing with a minimum thickness of 1 mm

Advanced Linear System ALS 21 with TP+ MA

Planetary gearbox TP+ 110 MA with rack module 4 and pinion RMW module 4

| | | | | |
|---|---|-----------------------|--|---------------------------|
| System | Max. feed force ¹⁾ F_{zT} | | 20900 N | |
| | Max. feed speed ²⁾ v_{max} | | 68 m/min | 23 m/min |
| Gearbox | No. of stages | | 2 | 3 |
| | Ratios i | | 22 / 27.5 / 38.5 / 55 | 66 / 88 / 110 / 154 / 220 |
| | Clamping hub diameter | | 38 / 48 mm | 38 mm |
| | Designation | | TP 110S-MA2-_-_-_-3_-_- | TP 110S-MA3-_-_-_-3_-_- |
| Pinion | Module m | | 4 mm | |
| | Number of teeth z | | 20 | |
| | Pitch circle diameter d | | 84.883 mm | |
| | Profile correction factor x | | 0.2 | |
| | Helix angle β | | -19.5283° (left-handed) | |
| | Designation | | RMW 400-444-20L1-073 | |
| Rack | Module m | | 4 mm | |
| | Lengths L | | 1000 mm (493 mm) | |
| | Helix angle β | | 19.5283° (right-handed) | |
| | Designation | | ZST 400-334-1000-R11; optionally with INIRA® | |
| Lubrication system ³⁾ | Set consisting of lubrication pinion and axis for | Rack | LMT 400-PU -18L1-040-1 | |
| | | Pinion | LMT 400-PU -18R1-040-1 | |
| | Lubricator | 125 cm ³ | LUC+125-0511-02 | |
| | | 400 cm ³ | LUC+400-0511-02 | |
| Lubricant | | WITTENSTEIN alpha G11 | | |

¹⁾ Maximum feed force depending on ratio and number of stages

²⁾ Calculation with lowest ratio and maximum input speed

³⁾ Impulse-controlled basic version with one output and 2 m hose. See page 116 for further information on the lubrication system.
Application-specific dimensioning with cymex® – www.wittenstein-cymex.com

Alternative system solutions

| Pinion | | | Axis distance | TP+ 110S HIGH TORQUE | TPM+ 110 HIGH TORQUE | TPK+ 110S HIGH TORQUE | Rack |
|-----------------------------|-------------|------------|---------------|-------------------------|-------------------------|--------------------------|---|
| Designation | d [mm] | x [] | A [mm] | F_{zT} [N] | F_{zT} [N] | F_{zT} [N] | Designation |
| RMW 400-444-20L1-073 | 84.882 | 0.2 | 78.241 | 20900 | 20900 | 20900 | ZST 400-334-1000-R11; optionally with INIRA® |
| RMW 500-444-19L1-089 | 100.798 | 0.4 | 86.399 | 20100 | 20100 | 20100 | ZST 500-332-1000-R1; optionally with INIRA® |
| RMF 400-443-40L1-125-12xM12 | 169.766 | 0 | 119.883 | 21800 | 21800 | 21800 | ZST 400-334-1000-R11; optionally with INIRA® |

d = Pitch circle diameter

x = Addendum modification coefficient

A = Distance between pinion axle and rear surface of rack

F_{zT} = Maximum feed force depending on ratio and number of stages

Application-specific dimensioning with cymex® – www.wittenstein-cymex.com

2-stage

up to 38⁴⁾ (K)
clamping hub
diameters

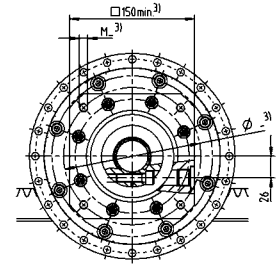
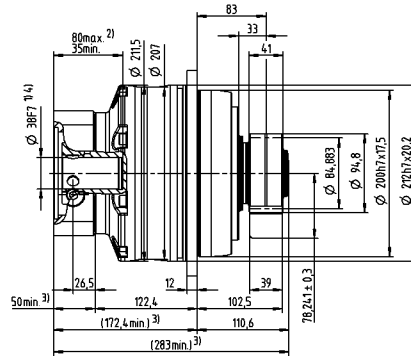
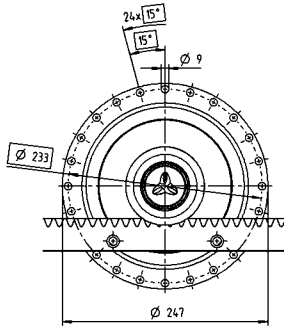

up to 48⁴⁾ (M)
clamping hub
diameters

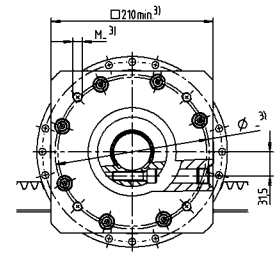
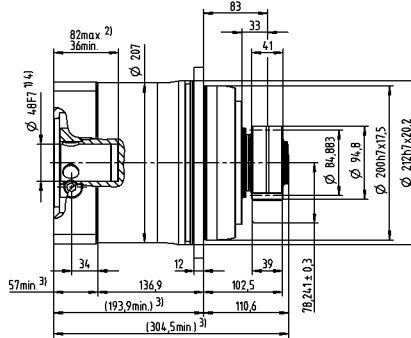
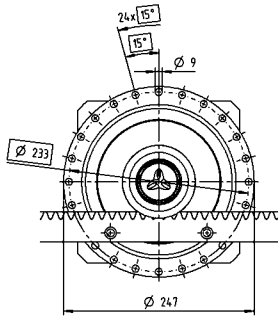

3-stage

up to 38⁴⁾ (K)
clamping hub
diameters

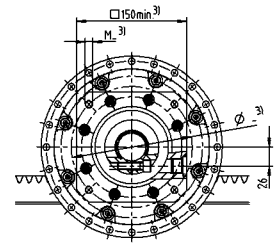
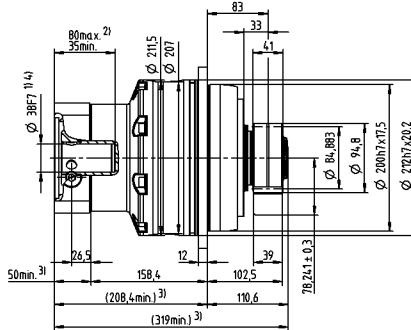
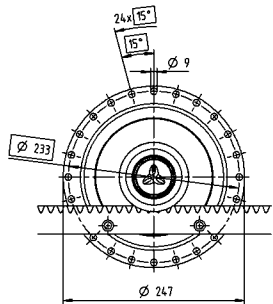

Motor shaft diameter [mm]

Advanced Linear
Systems

Non-tolerated dimensions are nominal dimensions
Detailed rack dimensions starting on page 151

¹⁾ Check motor shaft fit

²⁾ Min./Max. permissible motor shaft length. Longer motor shafts are possible, please contact alpha.

³⁾ The dimensions depend on the motor

⁴⁾ Smaller motor shaft diameter is compensated by a bushing with a minimum thickness of 1 mm



Premium Linear Systems
from WITTENSTEIN alpha –
Perfection in the application

Premium Linear Systems – the perfect solution for linear feed drives in machine tools and highly dynamic automation solutions

The Premium Linear System with **XP+** and associated right-angle and servo actuator versions is used predominantly as a single drive within a range of up to 11,000 N/drive.

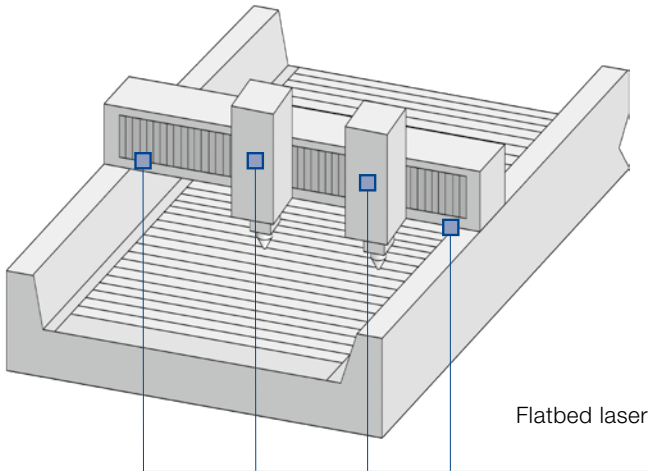

Flatbed laser

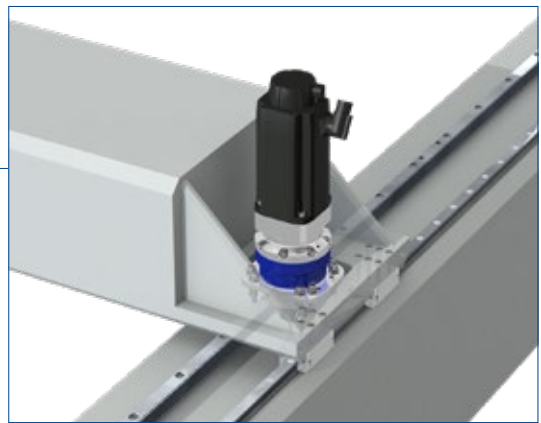

The Premium Linear System with **RP+** and associated right-angle and servo actuator versions is mostly used in an electrically braced master/slave configuration in machine tools, allowing feed forces of up to 113,000 N/drive.

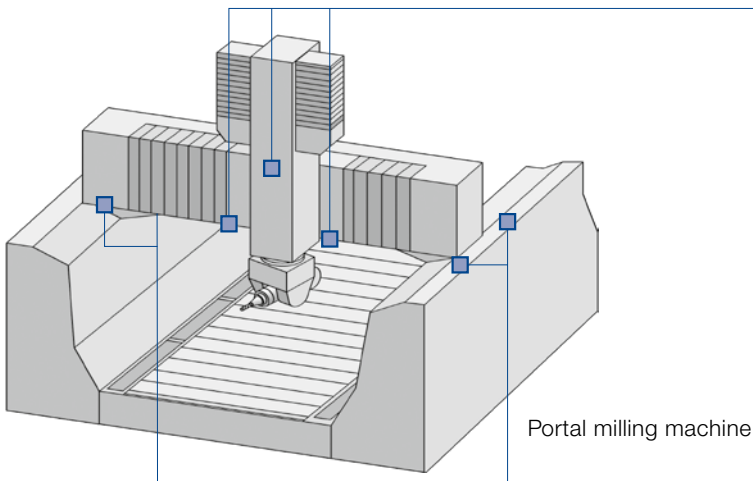

Portal milling machine

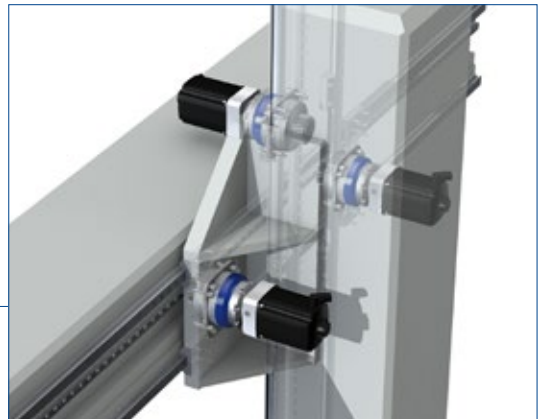

New dimensions in performance

With the Premium Linear System, the performance of the rack and pinion system reaches a new dimension. While others are still busy adapting existing solutions, WITTENSTEIN alpha has stayed several steps ahead with the improved new linear systems. The innovative Premium Linear Systems are used in applications where the individual requirements far exceed what has previously been possible. Compared to the industry standard, the values have been improved by 150 % on average.

Your benefits in comparison to the industry standard

- 150 % Greater feed force**
- 100 % Higher power density**
- 50 % Greater system reliability**
- 50 % Less mounting effort**
- 15 % Greater positioning accuracy**

| | Premium Linear System | Max. feed force [N] | Max. feed speed [m/min] |
|----------------------|-----------------------|---------------------|-------------------------|
| with XP ⁺ | PLS 5 | 5450 | 333 |
| | PLS 8 | 8350 | 244 |
| | PLS 11 | 10700 | 333 |
| with RP ⁺ | PLS 10 | 9750 | 133 |
| | PLS 13 | 12900 | 200 |
| | PLS 20 | 20300 | 250 |
| | PLS 22 | 22300 | 104 |
| | PLS 36 | 36100 | 112 |
| | PLS 47 | 47000 | 135 |
| | PLS 75 | 75000 | 91 |
| | PLS 112 | 112000 | 111 |

Feed force and feed speed dependent on ratio



XP⁺



RP⁺

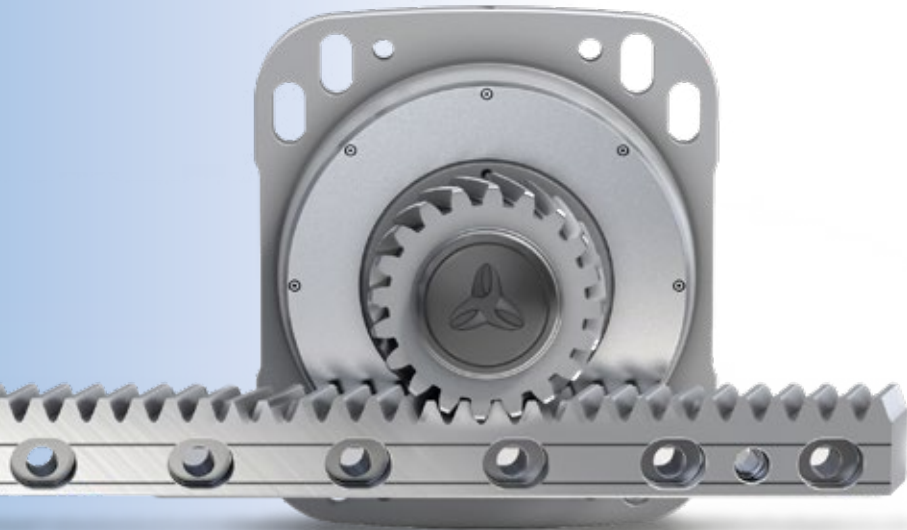

Quick system selection

XP+

RP+

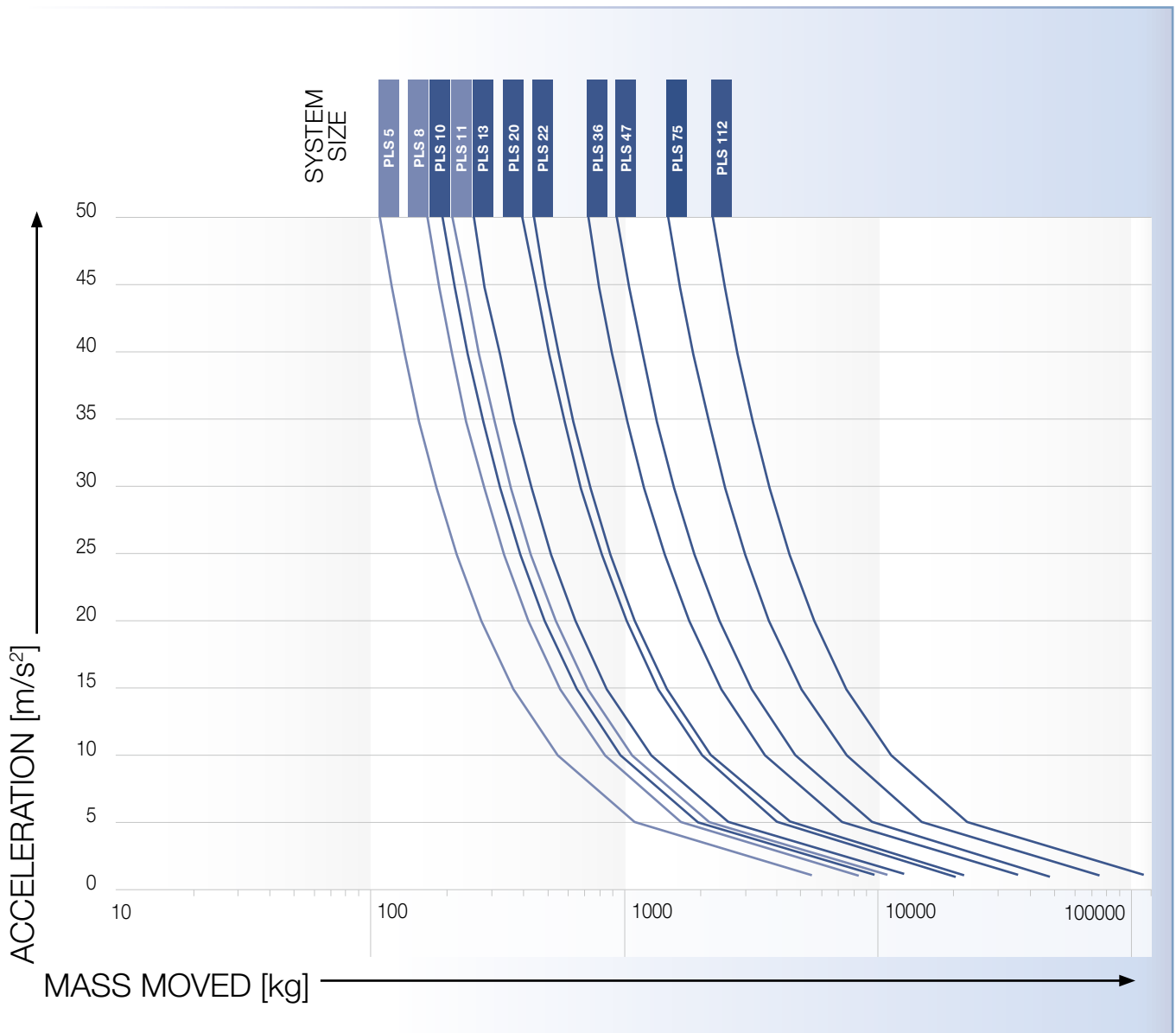

Premium Linear Systems

Premium Linear Systems overview

Our preferred linear systems are always comprised of the perfect combination of gearbox, pinion, rack and lubrication system. The systems are optimized to achieve the required feed force, feed speed, rigidity and degree of utilization of the individual components. Depending on your individual requirements, you have the option to further configure products via the ordering code. For a detailed dimensioning and configuration of the products we recommend to use cymex® 5.

| System | Gearbox | Pinion | Rack |
|---------|----------------------|----------------------|----------------------|
| PLS 5 | XP ⁺ 020R | RMW 200-444-20L1-033 | ZST 200-333-1000-R1 |
| PLS 8 | XP ⁺ 030R | RMW 200-444-20L1-037 | ZST 200-333-1000-R1 |
| PLS 11 | XP ⁺ 040R | RMW 300-444-20L1-055 | ZST 300-333-1000-R1 |
| PLS 10 | RP ⁺ 030S | RMW 200-444-20L1-037 | ZST 200-334-1000-R11 |
| PLS 13 | RP ⁺ 030S | RMW 300-444-20L1-055 | ZST 300-334-1000-R11 |
| PLS 20 | RP ⁺ 040S | RMW 300-444-20L1-055 | ZST 300-334-1000-R11 |
| PLS 22 | RP ⁺ 040S | RMW 400-444-20L1-073 | ZST 400-334-1000-R11 |
| PLS 36 | RP ⁺ 050S | RMW 400-444-24L1-089 | ZST 400-334-1000-R11 |
| PLS 47 | RP ⁺ 050S | RMW 500-444-23L1-106 | ZST 500-334-1000-R11 |
| PLS 75 | RP ⁺ 060S | RMW 600-444-23L1-128 | ZST 600-334-1000-R11 |
| PLS 112 | RP ⁺ 080S | RMW 800-444-21L1-156 | ZST 800-334-960-R11 |

Assembly accessories can be found starting at page 128 and information on the lubrication system starting at page 116

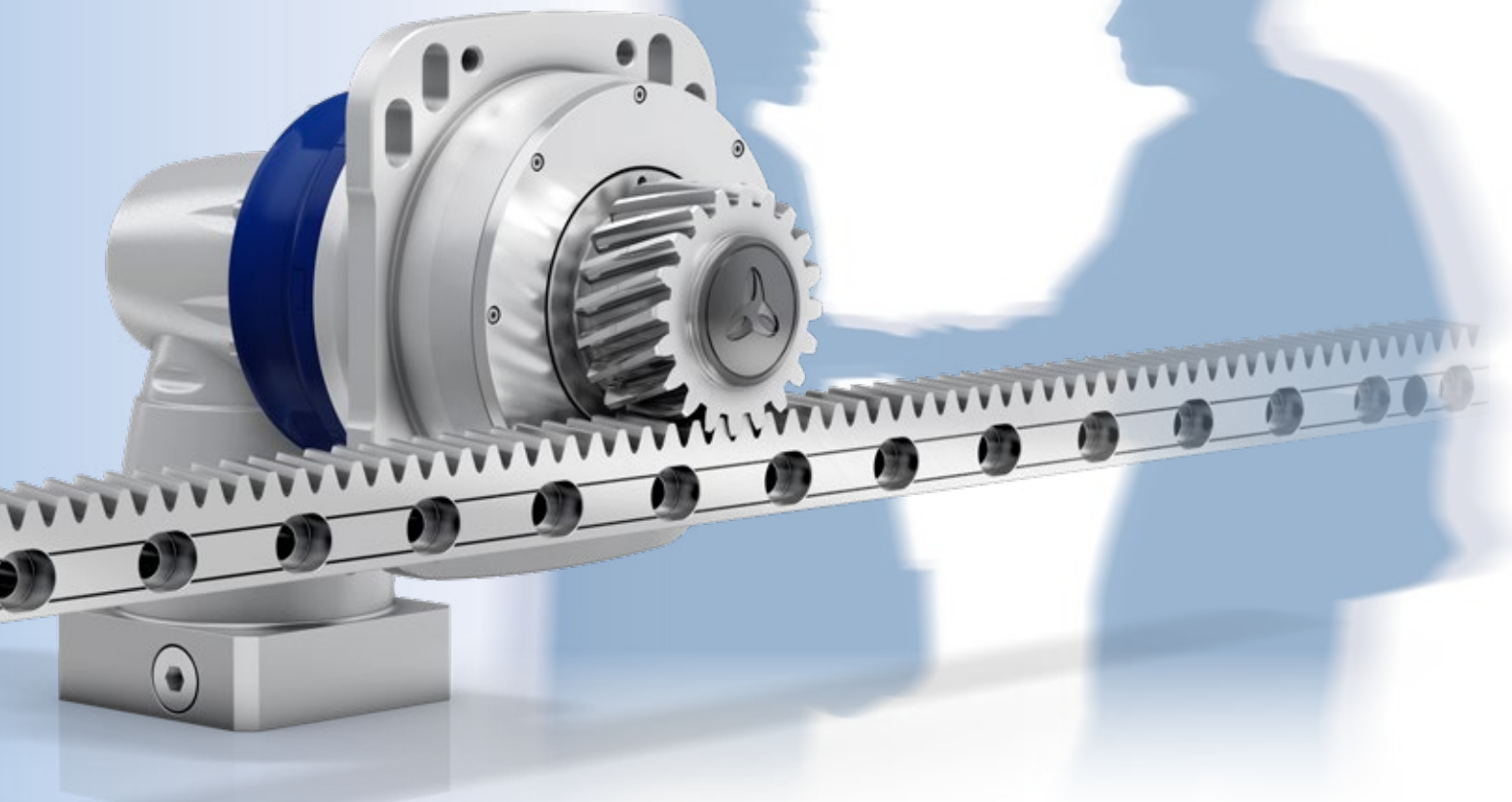

Ordering code

Gearbox*

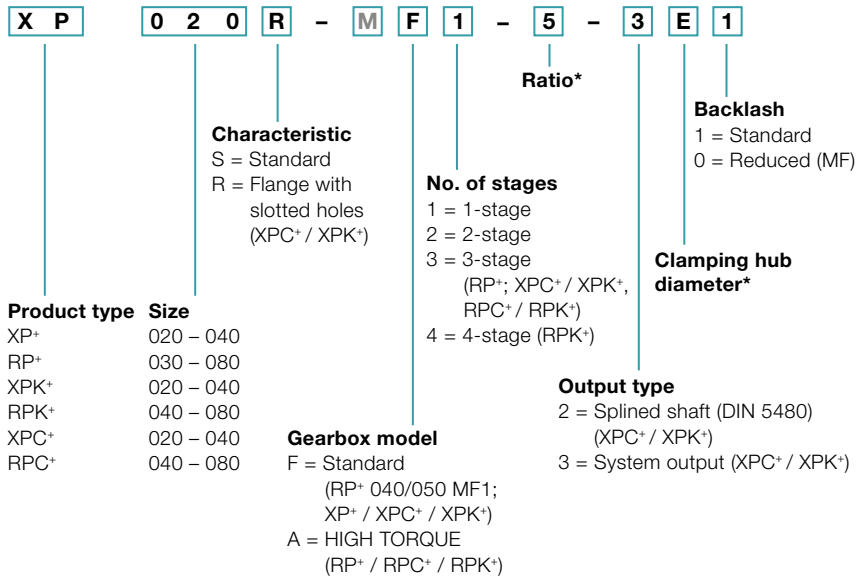

M Components with a gray font cannot be selected

* Further information about the gearboxes can be obtained from the respective catalogs, online at www.wittenstein-alpha.com or on request

** Full motor designation only required to determine gearbox mounting parts

Rack

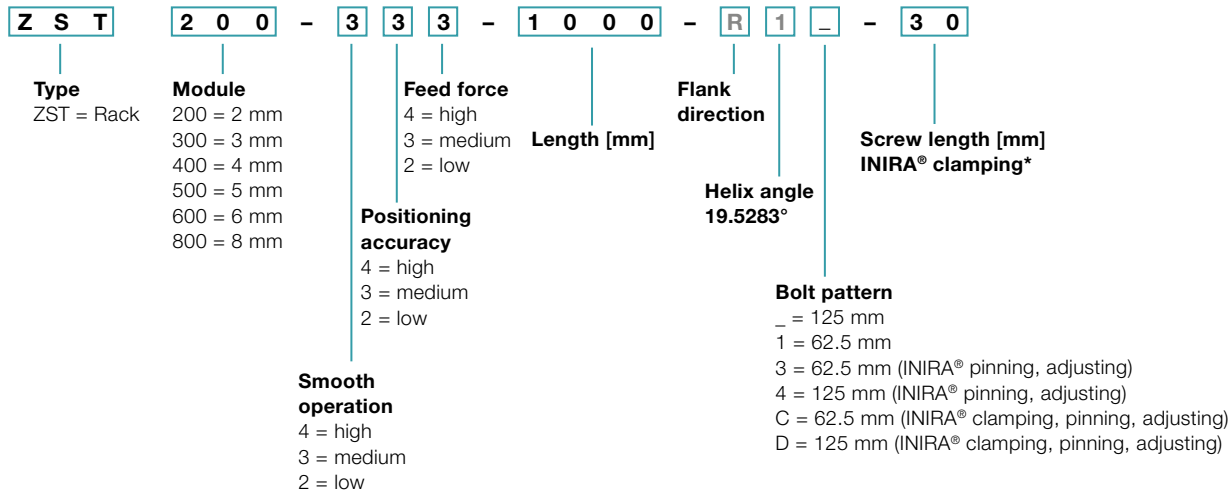

* Please refer to page 130 for an overview of available screw lengths

Pinion

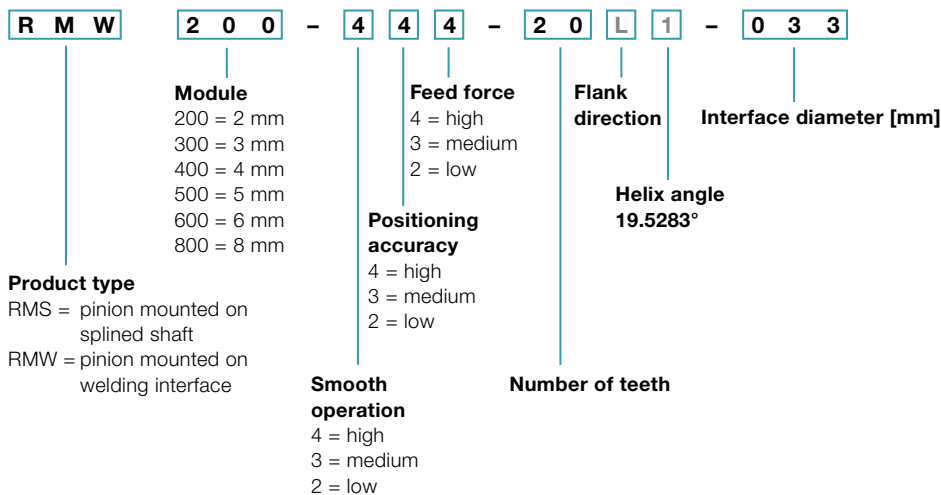

Premium Linear System PLS 5 with XP+

Planetary gearbox XP+ 020R MF with rack module 2 and pinion RMW module 2

| | | | | |
|---|---|---------------------|---|---|
| System | Max. feed force ¹⁾ F_{2T} | | 5450 N | |
| | Max. feed speed ²⁾ v_{max} | | 333 m/min | 71 m/min |
| Gearbox | No. of stages | | 1 | 2 |
| | Ratios i | | 3 / 4 / 5 / 7 / 8 / 10 | 16 / 20 / 25 / 28 / 32 / 35 / 40 / 50 / 64 / 70 / 100 |
| | Clamping hub diameter | | 14 / 24 mm | 11 / 19 mm |
| | Designation | | XP 020R-MF1-_-_-_-3_-_- | XP 020R-MF2-_-_-_-3_-_- |
| Pinion | Module m | | 2 mm | |
| | Number of teeth z | | 20 | |
| | Pitch circle diameter d | | 42.441 mm | |
| | Profile correction factor x | | 0.4 | |
| | Helix angle β | | -19.5283° (left-handed) | |
| | Designation | | RMW 200-444-20L1-033 | |
| Rack | Module m | | 2 mm | |
| | Lengths L | | 1000 mm (500 mm) | |
| | Helix angle β | | 19.5283° (right-handed) | |
| | Designation | | ZST 200-333-1000-R1; optionally with INIRA® | |
| Lubrication system ³⁾ | Set consisting of lubrication pinion and axis for | Rack | LMT 200-PU -18L1-024-1 | |
| | | Pinion | LMT 200-PU -18R1-024-1 | |
| | Lubricator | 125 cm ³ | LUC+125-0511-02 | |
| | | 400 cm ³ | LUC+400-0511-02 | |
| | Lubricant | | WITTENSTEIN alpha G11 | |

¹⁾ Maximum feed force depending on ratio and number of stages

²⁾ Calculation with lowest ratio and maximum input speed

³⁾ Impulse-controlled basic version with one output and 2 m hose. See page 116 for further information on the lubrication system. Application-specific dimensioning with cymex® – www.wittenstein-cymex.com

Alternative system solutions

| Pinion | | | Axis distance | XP+ 020R | PHG 2R | XPC+ 020R | XPK+ 020R | Rack |
|----------------------|-------------|------------|---------------|-----------------|-----------------|-----------------|-----------------|---|
| Designation | d [mm] | x [] | A [mm] | F_{2T} [N] | F_{2T} [N] | F_{2T} [N] | F_{2T} [N] | Designation |
| RMW 200-444-20L1-033 | 42.441 | 0.4 | 44.021 | 5450 | 5450 | 5450 | 5450 | ZST 200-333-1000-R1; optionally with INIRA® |
| RMS 200-323-18L1-022 | 38.197 | 0.4 | 41.899 | 5400 | 5400 | 5400 | 5400 | ZST 200-333-1000-R1; optionally with INIRA® |
| RMS 200-323-20L1-022 | 42.441 | 0.4 | 44.021 | 5300 | 5300 | 5300 | 5300 | ZST 200-333-1000-R1; optionally with INIRA® |
| RMS 200-323-22L1-022 | 46.686 | 0.4 | 46.143 | 5100 | 5100 | 5100 | 5100 | ZST 200-333-1000-R1; optionally with INIRA® |

d = Pitch circle diameter

x = Addendum modification coefficient

A = Distance between pinion axle and rear surface of rack

F_{2T} = Maximum feed force depending on ratio and number of stages

Application-specific dimensioning with cymex® – www.wittenstein-cymex.com

1-stage

greater than 14 (C) up to 19⁴⁾ (E) clamping hub diameters

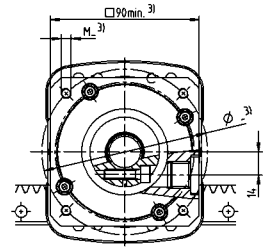
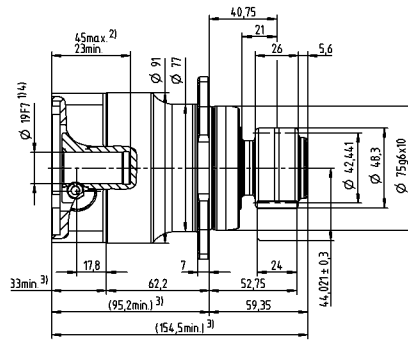
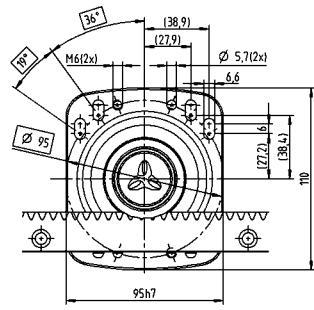

up to 24⁴⁾ (G) clamping hub diameters

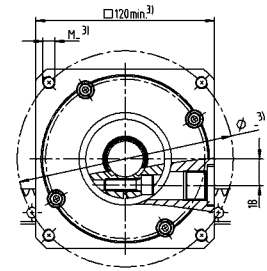
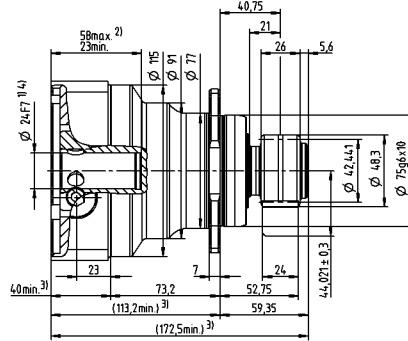
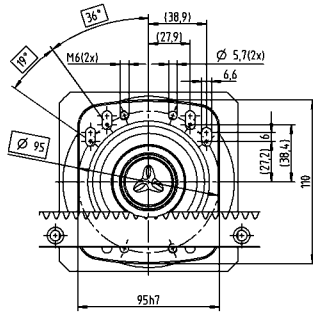

2-stage

greater than 11 (B) up to 14⁴⁾ (C) clamping hub diameters

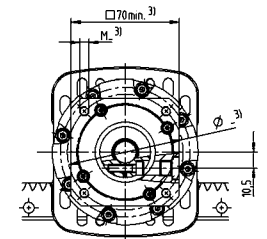
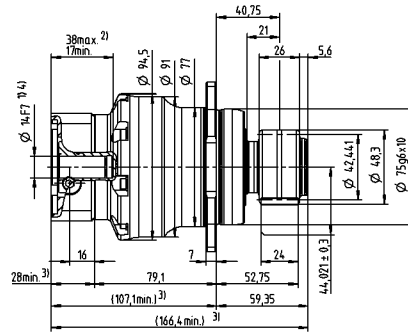
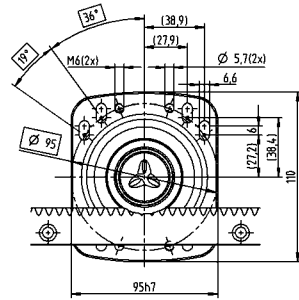

up to 19⁴⁾ (E) clamping hub diameters

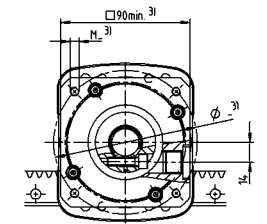
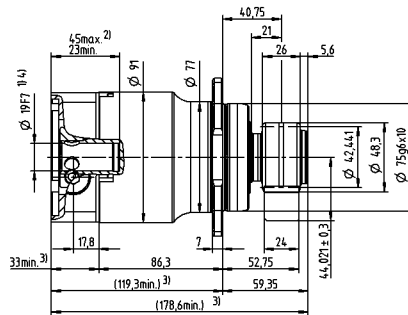
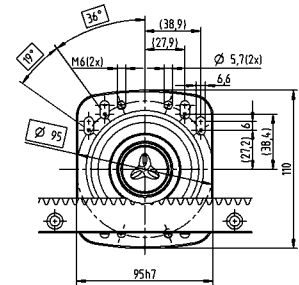

Motor shaft diameter [mm]

Non-tolerated dimensions are nominal dimensions
 Detailed rack dimensions starting on page 151
¹⁾ Check motor shaft fit
²⁾ Min./Max. permissible motor shaft length. Longer motor shafts are possible, please contact alpha.
³⁾ The dimensions depend on the motor
⁴⁾ Smaller motor shaft diameter is compensated by a bushing with a minimum thickness of 1 mm

Premium Linear System PLS 8 with XP+

Planetary gearbox XP+ 030R MF with rack module 2 and pinion RMW module 2

| | | | | |
|---|---|---------------------|--|---|
| System | Max. feed force ¹⁾ F_{2T} | | 8350 N | |
| | Max. feed speed ²⁾ v_{max} | | 244 m/min | 54 m/min |
| Gearbox | No. of stages | | 1 | 2 |
| | Ratios i | | 3 / 4 / 5 / 7 / 8 / 10 | 16 / 20 / 25 / 28 / 32 / 35 / 40 / 50 / 64 / 70 / 100 |
| | Clamping hub diameter | | 19 / 24 / 28 / 38 mm | 14 / 19 / 24 / 28 mm |
| | Designation | | XP 030R-MF1-_-3-_- | XP 030R-MF2-_-3-_- |
| Pinion | Module m | | 2 mm | |
| | Number of teeth z | | 20 | |
| | Pitch circle diameter d | | 42.441 mm | |
| | Profile correction factor x | | 0.4 | |
| | Helix angle β | | -19.5283° (left-handed) | |
| | Designation | | RMW 200-444-20L1-037 | |
| Rack | Module m | | 2 mm | |
| | Lengths L | | 1000 mm (500 mm) | |
| | Helix angle β | | 19.5283° (right-handed) | |
| | Designation | | ZST 200-334-1000-R11; optionally with INIRA® | |
| Lubrication system ³⁾ | Set consisting of lubrication pinion and axis for | Rack | LMT 200-PU -18L1-024-1 | |
| | | Pinion | LMT 200-PU -18R1-024-1 | |
| | Lubricator | 125 cm ³ | LUC+125-0511-02 | |
| | | 400 cm ³ | LUC+400-0511-02 | |
| | Lubricant | | WITTENSTEIN alpha G11 | |

¹⁾ Maximum feed force depending on ratio and number of stages

²⁾ Calculation with lowest ratio and maximum input speed

³⁾ Impulse-controlled basic version with one output and 2 m hose. See page 116 for further information on the lubrication system. Application-specific dimensioning with cymex® – www.wittenstein-cymex.com

Alternative system solutions

| Pinion | | | Axis distance | XP+ 030R | PHG 3R | XPC+ 030R | XPK+ 030R | Rack |
|----------------------|-------------|------------|---------------|-----------------|-----------------|-----------------|-----------------|--|
| Designation | d [mm] | x [] | A [mm] | F_{2T} [N] | F_{2T} [N] | F_{2T} [N] | F_{2T} [N] | Designation |
| RMW 200-444-20L1-037 | 42.441 | 0.4 | 44.021 | 8350 | 8350 | 8350 | 8350 | ZST 200-334-1000-R11; optionally with INIRA® |
| RMW 200-444-40L1-037 | 84.883 | 0.3 | 65.041 | 6100 | 6100 | 6100 | 6100 | ZST 200-333-1000-R1; optionally with INIRA® |
| RMW 300-444-20L1-037 | 63.662 | 0.4 | 59.031 | 7200 | 7200 | 7200 | 7200 | ZST 300-332-1000-R1; optionally with INIRA® |
| RMS 200-323-23L1-032 | 48.808 | 0.4 | 47.204 | 8350 | 8350 | 8350 | 8350 | ZST 200-334-1000-R11; optionally with INIRA® |
| RMS 200-323-25L1-032 | 53.052 | 0.4 | 49.326 | 8350 | 8350 | 8350 | 8350 | ZST 200-334-1000-R11; optionally with INIRA® |
| RMS 200-323-27L1-032 | 57.296 | 0.3 | 51.248 | 8350 | 8350 | 8350 | 8350 | ZST 200-334-1000-R11; optionally with INIRA® |

d = Pitch circle diameter

x = Addendum modification coefficient

A = Distance between pinion axle and rear surface of rack

F_{2T} = Maximum feed force depending on ratio and number of stages

Application-specific dimensioning with cymex® – www.wittenstein-cymex.com

1-stage

greater than 19 (E)
up to 24/28⁴⁾ (G/H)
clamping hub
diameters

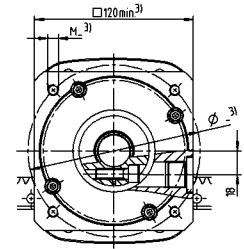
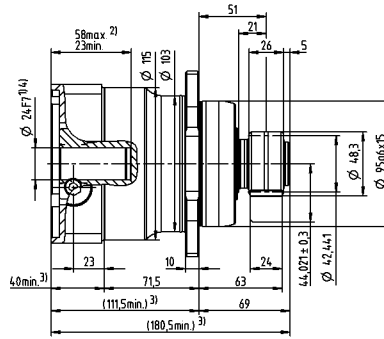
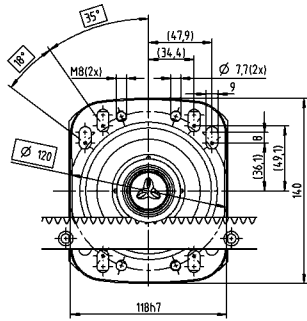

up to 38⁴⁾ (K)
clamping hub
diameters

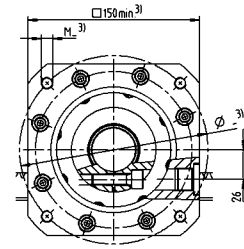
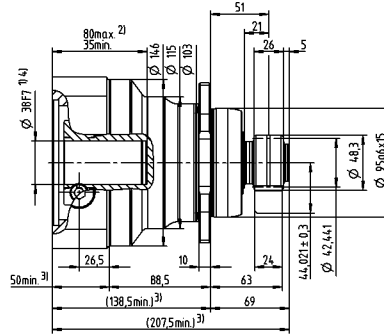
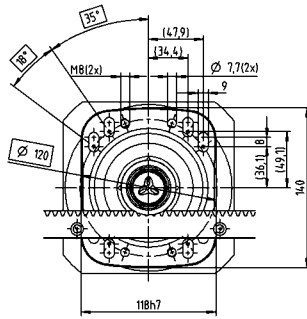

2-stage

greater than 14 (C)
up to 19⁴⁾ (E)
clamping hub
diameters

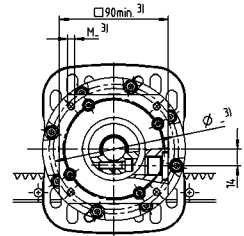
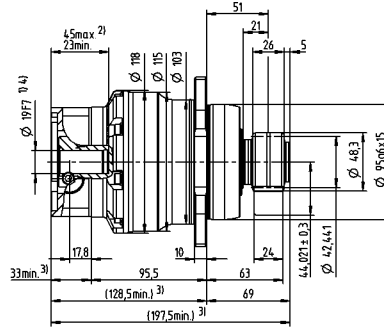
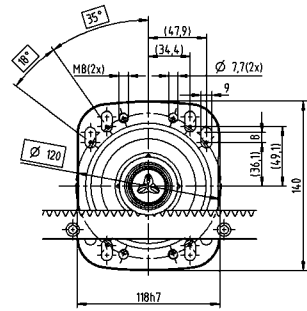

up to 28⁴⁾ (G)
clamping hub
diameters

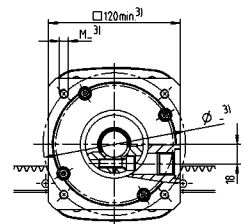
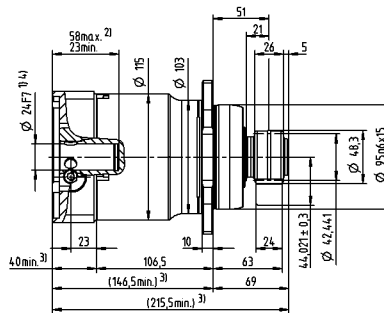
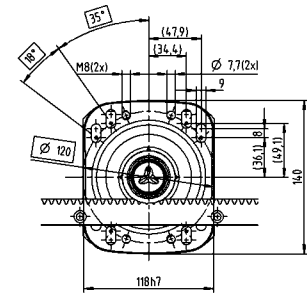

Non-tolerated dimensions are nominal dimensions
Detailed rack dimensions starting on page 151

¹⁾ Check motor shaft fit

²⁾ Min./Max. permissible motor shaft length. Longer motor shafts are possible, please contact alpha.

³⁾ The dimensions depend on the motor

⁴⁾ Smaller motor shaft diameter is compensated by a bushing with a minimum thickness of 1 mm

Motor shaft diameter [mm]

Premium Linear System PLS 11 with XP+

Planetary gearbox XP+ 040R MF with rack module 3 and pinion RMW module 3

| | | | | |
|---|---|---------------------|---|---|
| System | Max. feed force ¹⁾ F_{2T} | | 10700 N | |
| | Max. feed speed ²⁾ v_{max} | | 333 m/min | 75 m/min |
| Gearbox | No. of stages | | 1 | 2 |
| | Ratios i | | 3 / 4 / 5 / 7 / 8 / 10 | 16 / 20 / 25 / 28 / 32 / 35 / 40 / 50 / 64 / 70 / 100 |
| | Clamping hub diameter | | 24 / 32 / 38 / 48 mm | 19 / 24 / 38 mm |
| | Designation | | XP 040R-MF1-_-_-3-_-_- | XP 040R-MF2-_-_-3-_-_- |
| Pinion | Module m | | 3 mm | |
| | Number of teeth z | | 20 | |
| | Pitch circle diameter d | | 63.662 mm | |
| | Profile correction factor x | | 0.4 | |
| | Helix angle β | | -19.5283° (left-handed) | |
| | Designation | | RMW 300-444-20L1-055 | |
| Rack | Module m | | 3 mm | |
| | Lengths L | | 1000 mm (500 mm) | |
| | Helix angle β | | 19.5283° (right-handed) | |
| | Designation | | ZST 300-333-1000-R1; optionally with INIRA® | |
| Lubrication system ³⁾ | Set consisting of lubrication pinion and axis for | Rack | LMT 300-PU -18L1-030-1 | |
| | | Pinion | LMT 300-PU -18R1-030-1 | |
| | Lubricator | 125 cm ³ | LUC+125-0511-02 | |
| | | 400 cm ³ | LUC+400-0511-02 | |
| | Lubricant | | WITTENSTEIN alpha G11 | |

¹⁾ Maximum feed force depending on ratio and number of stages

²⁾ Calculation with lowest ratio and maximum input speed

³⁾ Impulse-controlled basic version with one output and 2 m hose. See page 116 for further information on the lubrication system. Application-specific dimensioning with cymex® – www.wittenstein-cymex.com

Alternative system solutions

| Pinion | | | Axis distance | XP+ 040R | XPK+ 040R | XPC+ 040R | Rack |
|----------------------|-------------|------------|---------------|-----------------|-----------------|-----------------|--|
| Designation | d [mm] | x [] | A [mm] | F_{2T} [N] | F_{2T} [N] | F_{2T} [N] | Designation |
| RMW 200-444-40L1-055 | 84.883 | 0 | 64.441 | 10700 | 10700 | 10700 | ZST 200-334-1000-R11; optionally with INIRA® |
| RMW 300-444-20L1-055 | 63.662 | 0.4 | 59.031 | 10700 | 10700 | 10700 | ZST 300-333-1000-R1; optionally with INIRA® |
| RMW 300-444-34L1-055 | 108.226 | 0 | 80.113 | 10700 | 10700 | 10700 | ZST 300-333-1000-R1; optionally with INIRA® |
| RMS 300-323-20L1-040 | 63.662 | 0.4 | 59.031 | 10700 | 10700 | 10700 | ZST 300-333-1000-R1; optionally with INIRA® |
| RMS 300-323-22L1-040 | 70.028 | 0.4 | 62.214 | 10700 | 10700 | 10700 | ZST 300-333-1000-R1; optionally with INIRA® |
| RMS 300-323-24L1-040 | 76.394 | 0.4 | 65.397 | 10700 | 10700 | 10700 | ZST 300-333-1000-R1; optionally with INIRA® |

d = Pitch circle diameter

x = Addendum modification coefficient

A = Distance between pinion axle and rear surface of rack

F_{2T} = Maximum feed force depending on ratio and number of stages

Application-specific dimensioning with cymex® – www.wittenstein-cymex.com

1-stage

greater than 24 (G)
up to 32/38⁴⁾ (I/K)
clamping hub
diameters

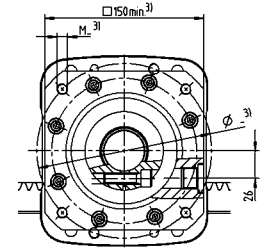
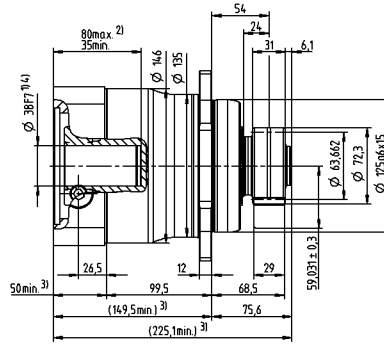
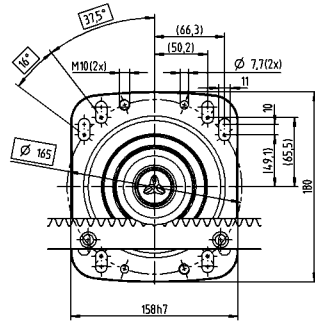

up to 48⁴⁾ (M)
clamping hub
diameters

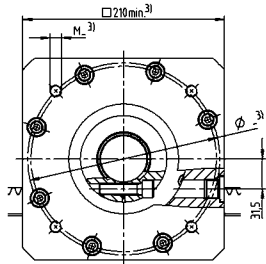
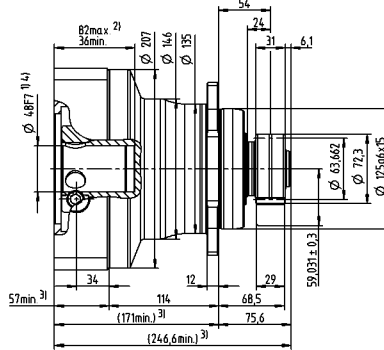
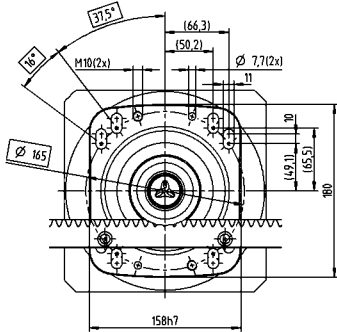

2-stage

greater than 19 (E)
up to 24⁴⁾ (G)
clamping hub
diameters

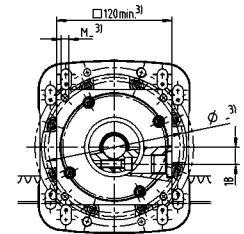
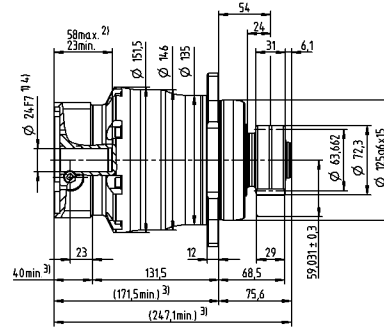
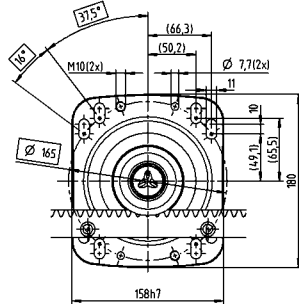

up to 38⁴⁾ (K)
clamping hub
diameters

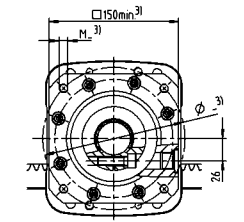
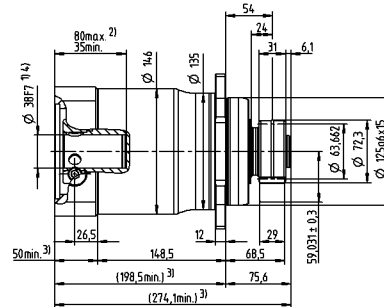
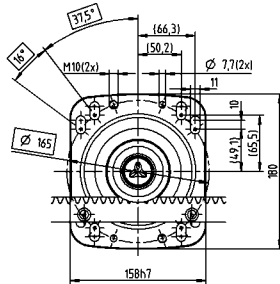

Motor shaft diameter [mm]

Non-tolerated dimensions are nominal dimensions
Detailed rack dimensions starting on page 151
1) Check motor shaft fit
2) Min./Max. permissible motor shaft length. Longer motor shafts are possible, please contact alpha.
3) The dimensions depend on the motor
4) Smaller motor shaft diameter is compensated by a bushing with a minimum thickness of 1 mm

Premium Linear System PLS 10 with RP+

Planetary gearbox RP+ 030 MA with rack module 2 and pinion RMW module 2

| | | | |
|---|---|---------------------|--|
| System | Max. feed force ¹⁾ F_{2T} | | 9750 N |
| | Max. feed speed ²⁾ v_{max} | | 133 m/min |
| Gearbox | No. of stages ⁴⁾ | | 1 |
| | Ratios i ⁵⁾ | | 5.5 |
| | Clamping hub diameter | | 19 / 24 / 38 mm |
| | Designation | | RP 030S-MA1-__-__-3-__ |
| Pinion | Module m | | 3 mm |
| | Number of teeth z | | 20 |
| | Pitch circle diameter d | | 42.441 mm |
| | Profile correction factor x | | 0.4 |
| | Helix angle β | | -19.5283° (left-handed) |
| | Designation | | RMW 200-444-20L1-037 |
| Rack | Module m | | 2 mm |
| | Lengths L | | 1000 mm (500 mm) |
| | Helix angle β | | 19.5283° (right-handed) |
| | Designation | | ZST 200-334-1000-R11; optionally with INIRA® |
| Lubrication system ³⁾ | Set consisting of lubrication pinion and axis for | Rack | LMT 200-PU -18L1-024-1 |
| | | Pinion | LMT 200-PU -18L1-024-1 |
| | Lubricator | 125 cm ³ | LUC+125-0511-02 |
| | | 400 cm ³ | LUC+400-0511-02 |
| | Lubricant | | WITTENSTEIN alpha G11 |

¹⁾ Maximum feed force depending on ratio and number of stages

²⁾ Calculation with lowest ratio and maximum input speed

³⁾ Impulse-controlled basic version with one output and 2 m hose. See page 116 for further information on the lubrication system.

Application-specific dimensioning with cymex® – www.wittenstein-cymex.com

⁴⁾ Also available with multiple stages.

⁵⁾ Additional 1-stage ratios 4 / 5 / 7 / 10 available for RP+ 030 MF

Alternative system solutions

| Pinion | | | Axis distance | RP+ 030S | Rack |
|----------------------|-------------|------------|---------------|-----------------|---|
| Designation | d [mm] | x [] | A [mm] | F_{2T} [N] | Designation |
| RMW 200-444-40L1-055 | 84.883 | 0 | 64.441 | 11300 | ZST 200-334-1000-R11; optionally with INIRA® |
| RMW 300-444-20L1-055 | 63.662 | 0.4 | 59.031 | 12900 | ZST 300-334-1000-R11; optionally with INIRA® |
| RMW 300-444-34L1-055 | 108.226 | 0 | 80.113 | 9800 | ZST 300-333-1000-R1; optionally with INIRA® |
| RMW 400-444-20L1-055 | 84.882 | 0.2 | 78.241 | 12500 | ZST 400-333-1000-R1; optionally with INIRA® |

d = Pitch circle diameter

x = Addendum modification coefficient

A = Distance between pinion axle and rear surface of rack

F_{2T} = Maximum feed force depending on ratio and number of stages

RP+ available in customized version

Application-specific dimensioning with cymex® – www.wittenstein-cymex.com

1-stage

up to 19⁴⁾ (E)
clamping hub
diameters

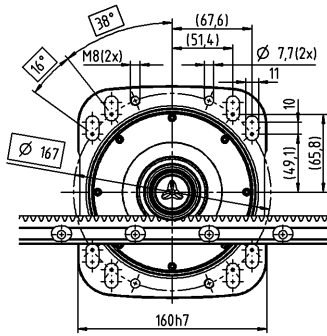

up to 24⁴⁾ (G)
clamping hub
diameters

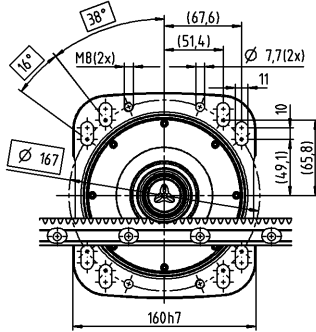

up to 38⁴⁾ (K)
clamping hub
diameters

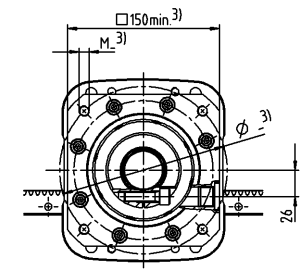
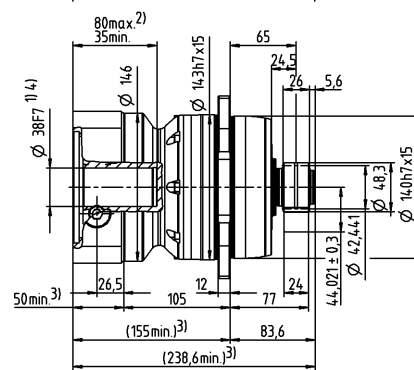
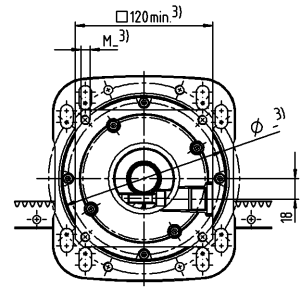
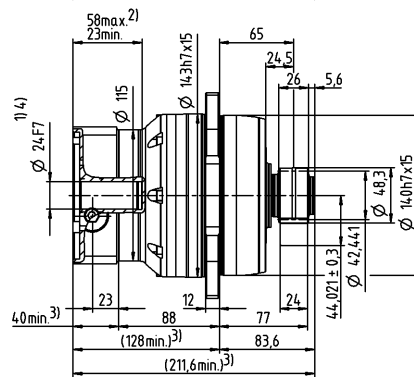
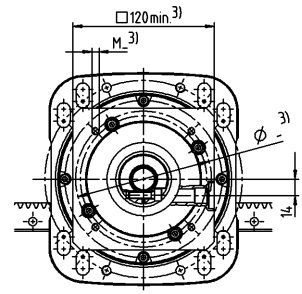
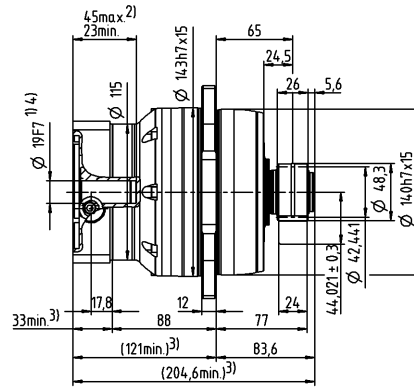
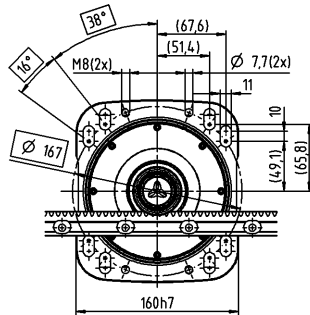

Non-tolerated dimensions are nominal dimensions
Detailed rack dimensions starting on page 151

¹⁾ Check motor shaft fit

²⁾ Min./Max. permissible motor shaft length. Longer motor shafts are possible, please contact alpha.

³⁾ The dimensions depend on the motor

⁴⁾ Smaller motor shaft diameter is compensated by a bushing with a minimum thickness of 1 mm

Motor shaft diameter [mm]

Premium Linear System PLS 13 with RP+

Planetary gearbox RP+ 030 MA with rack module 3 and pinion RMW module 3

| | | | |
|---|---|---------------------|--|
| System | Max. feed force ¹⁾ F_{2T} | | 12900 N |
| | Max. feed speed ²⁾ v_{max} | | 200 m/min |
| Gearbox | No. of stages ⁴⁾ | | 1 |
| | Ratios i ⁵⁾ | | 5.5 |
| | Clamping hub diameter | | 19 / 24 / 38 mm |
| | Designation | | RP 030S-MA1-__-__-3-__ |
| Pinion | Module m | | 3 mm |
| | Number of teeth z | | 20 |
| | Pitch circle diameter d | | 63.662 mm |
| | Profile correction factor x | | 0.4 |
| | Helix angle β | | -19.5283° (left-handed) |
| | Designation | | RMW 300-444-20L1-055 |
| Rack | Module m | | 3 mm |
| | Lengths L | | 1000 mm (500 mm) |
| | Helix angle β | | 19.5283° (right-handed) |
| | Designation | | ZST 300-334-1000-R11; optionally with INIRA® |
| Lubrication system ³⁾ | Set consisting of lubrication pinion and axis for | Rack | LMT 300-PU -18L1-030-1 |
| | | Pinion | LMT 300-PU -18R1-030-1 |
| | Lubricator | 125 cm ³ | LUC+125-0511-02 |
| | | 400 cm ³ | LUC+400-0511-02 |
| | Lubricant | | WITTENSTEIN alpha G11 |

¹⁾ Maximum feed force depending on ratio and number of stages

²⁾ Calculation with lowest ratio and maximum input speed

³⁾ Impulse-controlled basic version with one output and 2 m hose. See page 116 for further information on the lubrication system.

Application-specific dimensioning with cymex® – www.wittenstein-cymex.com

⁴⁾ Also available with multiple stages.

⁵⁾ Additional 1-stage ratios 4 / 5 / 7 / 10 available for RP+ 030 MF

Alternative system solutions

| Pinion | | | Axis distance | RP+ 030S | Rack |
|----------------------|-------------|------------|---------------|-----------------|---|
| Designation | d [mm] | x [] | A [mm] | F_{2T} [N] | Designation |
| RMW 200-444-20L1-037 | 42.441 | 0.4 | 44.021 | 9750 | ZST 200-334-1000-R11; optionally with INIRA® |
| RMW 200-444-40L1-055 | 84.883 | 0 | 64.441 | 11300 | ZST 200-334-1000-R11; optionally with INIRA® |
| RMW 300-444-34L1-055 | 108.226 | 0 | 80.113 | 9800 | ZST 300-333-1000-R1; optionally with INIRA® |
| RMW 400-444-20L1-055 | 84.882 | 0.2 | 78.241 | 12500 | ZST 400-333-1000-R1; optionally with INIRA® |

d = Pitch circle diameter

x = Addendum modification coefficient

A = Distance between pinion axle and rear surface of rack

F_{2T} = Maximum feed force depending on ratio and number of stages

RP+ available in customized version

Application-specific dimensioning with cymex® – www.wittenstein-cymex.com

1-stage

up to 19⁴⁾ (E)
clamping hub
diameters

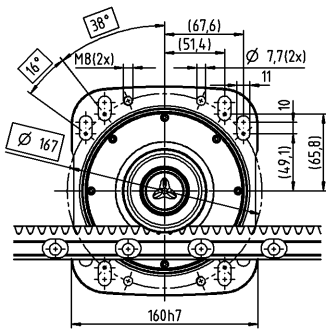

up to 24⁴⁾ (G)
clamping hub
diameters

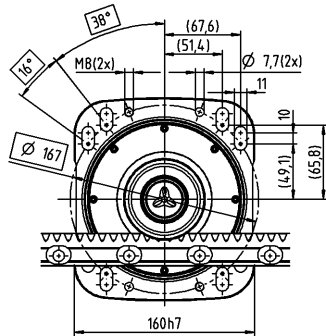

up to 38⁴⁾ (K)
clamping hub
diameters

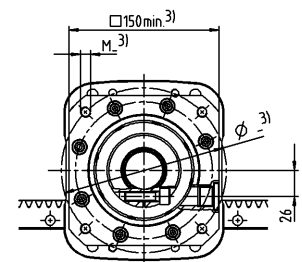
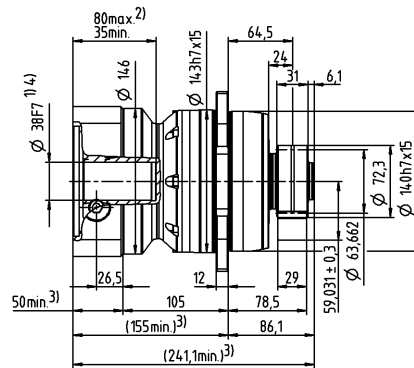
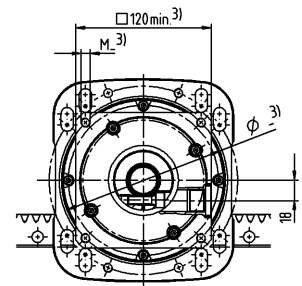
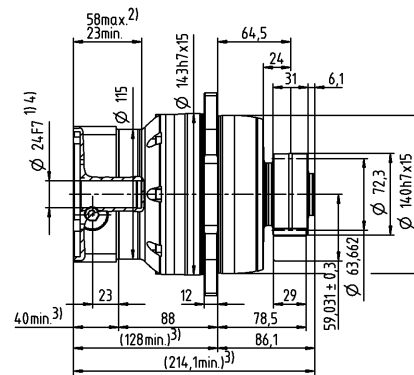
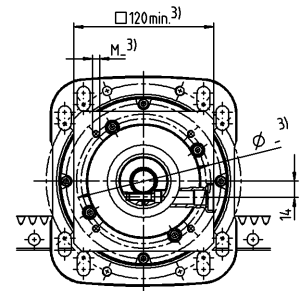
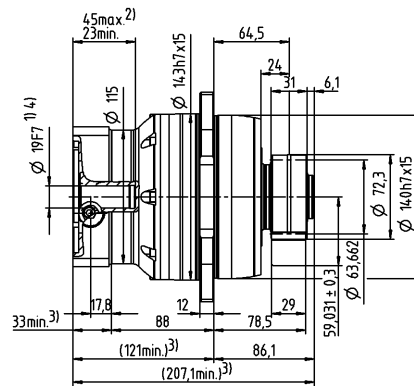
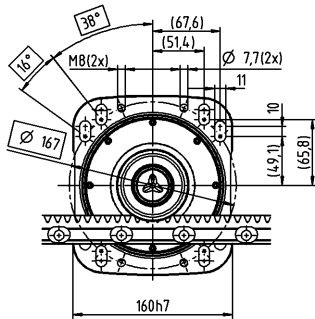

Non-tolerated dimensions are nominal dimensions
Detailed rack dimensions starting on page 151

¹⁾ Check motor shaft fit

²⁾ Min./Max. permissible motor shaft length. Longer motor shafts are possible, please contact alpha.

³⁾ The dimensions depend on the motor

⁴⁾ Smaller motor shaft diameter is compensated by a bushing with a minimum thickness of 1 mm

Motor shaft diameter [mm]

Premium Linear System PLS 20 with RP+

Planetary gearbox RP+ 040 MF with rack module 3 and pinion RMW module 3

| | | | |
|---|---|---------------------|--|
| System | Max. feed force ¹⁾ F_{2T} | | 20300 N |
| | Max. feed speed ²⁾ v_{max} | | 250 m/min |
| Gearbox | No. of stages | | 1 |
| | Ratios i | | 4 / 5 / 7 / 10 |
| | Clamping hub diameter | | 24 / 38 / 48 mm |
| | Designation | | RP 040S-MF1-_-_-3_ _ |
| Pinion | Module m | | 3 mm |
| | Number of teeth z | | 20 |
| | Pitch circle diameter d | | 63.662 mm |
| | Profile correction factor x | | 0.4 |
| | Helix angle β | | -19.5283° (left-handed) |
| | Designation | | RMW 300-444-20L1-055 |
| Rack | Module m | | 3 mm |
| | Lengths L | | 1000 mm (500 mm) |
| | Helix angle β | | 19.5283° (right-handed) |
| | Designation | | ZST 300-334-1000-R11; optionally with INIRA® |
| Lubrication system ³⁾ | Set consisting of lubrication pinion and axis for | Rack | LMT 300-PU -18L1-030-1 |
| | | Pinion | LMT 300-PU -18R1-030-1 |
| | Lubricator | 125 cm ³ | LUC+125-0511-02 |
| | | 400 cm ³ | LUC+400-0511-02 |
| | Lubricant | | WITTENSTEIN alpha G11 |

¹⁾ Maximum feed force depending on ratio and number of stages

²⁾ Calculation with lowest ratio and maximum input speed

³⁾ Impulse-controlled basic version with one output and 2 m hose. See page 116 for further information on the lubrication system.
Application-specific dimensioning with cymex® – www.wittenstein-cymex.com

Alternative system solutions

| Pinion | | | Axis distance | RP+ 040S | RPM+ 040S | Rack |
|----------------------|-------------|------------|---------------|-----------------|-----------------|---|
| Designation | d [mm] | x [] | A [mm] | F_{2T} [N] | F_{2T} [N] | Designation |
| RMW 300-444-20L1-055 | 63.662 | 0.4 | 59.031 | 20300 | 20300 | ZST 300-334-1000-R11; optionally with INIRA® |
| RMW 300-444-34L1-073 | 108.226 | 0 | 80.113 | 12900 | 12900 | ZST 300-334-1000-R11; optionally with INIRA® |
| RMW 400-444-20L1-073 | 84.882 | 0.2 | 78.241 | 16400 | 16400 | ZST 400-333-1000-R1; optionally with INIRA® |
| RMW 400-444-24L1-073 | 101.859 | 0 | 85.930 | 13700 | 13700 | ZST 400-333-1000-R1; optionally with INIRA® |
| RMW 500-444-19L1-073 | 100.798 | 0.4 | 86.399 | 13800 | 13800 | ZST 500-332-1000-R1; optionally with INIRA® |

d = Pitch circle diameter

x = Addendum modification coefficient

A = Distance between pinion axle and rear surface of rack

F_{2T} = Maximum feed force depending on ratio and number of stages

RPM+ available in customized version

Application-specific dimensioning with cymex® – www.wittenstein-cymex.com

1-stage

up to 24⁴⁾ (G)
clamping hub
diameters

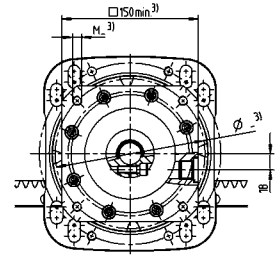
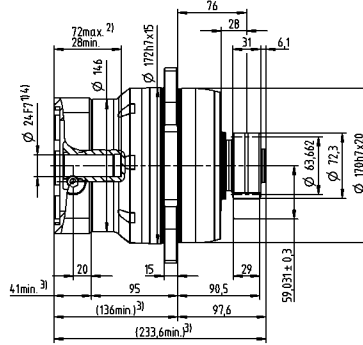
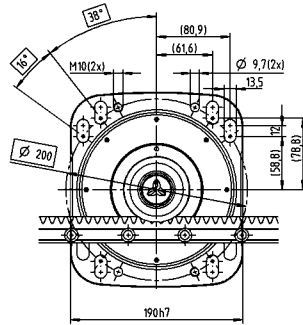

up to 38⁴⁾ (K)
clamping hub
diameters

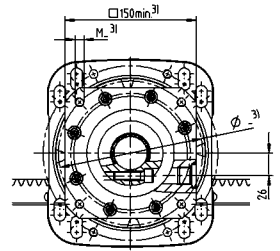
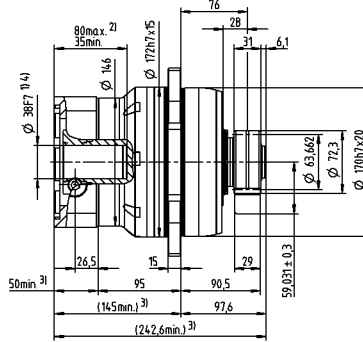
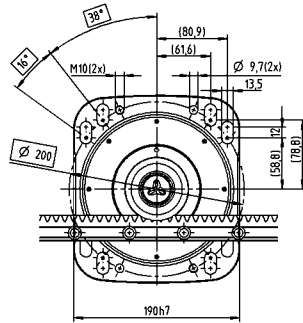

up to 48⁴⁾ (M)
clamping hub
diameters

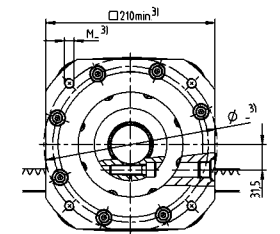
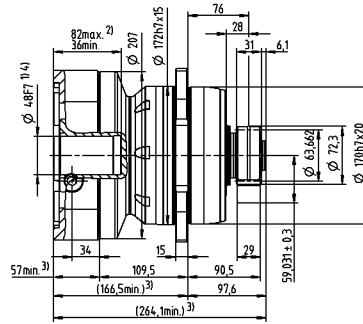
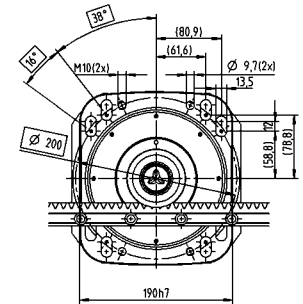

Motor shaft diameter [mm]

Non-tolerated dimensions are nominal dimensions
Detailed rack dimensions starting on page 151

¹⁾ Check motor shaft fit

²⁾ Min./Max. permissible motor shaft length. Longer motor shafts are possible, please contact alpha.

³⁾ The dimensions depend on the motor

⁴⁾ Smaller motor shaft diameter is compensated by a bushing with a minimum thickness of 1 mm

Premium Linear System PLS 22 with RP+

Planetary gearbox RP+ 040 MA with rack module 4 and pinion RMW module 4

| | | | | |
|---|---|-----------------------|--|---------------------------|
| System | Max. feed force ¹⁾ F_{zT} | | 22300 N | |
| | Max. feed speed ²⁾ v_{max} | | 104 m/min | 25 m/min |
| Gearbox | No. of stages ³⁾ | | 2 | 3 |
| | Ratios i | | 16 / 22 / 27.5 / 38.5 / 55 | 66 / 88 / 110 / 154 / 220 |
| | Clamping hub diameter | | 24 / 38 mm | 24 mm |
| | Designation | | RP 040S-MA2-_-_-_-3_ _ | RP 040S-MA3-_-_-_-3_ _ |
| Pinion | Module m | | 4 mm | |
| | Number of teeth z | | 20 | |
| | Pitch circle diameter d | | 84.883 mm | |
| | Profile correction factor x | | 0.2 | |
| | Helix angle β | | -19.5283° (left-handed) | |
| | Designation | | RMW 400-444-20L1-073 | |
| Rack | Module m | | 4 mm | |
| | Lengths L | | 1000 mm (493 mm) | |
| | Helix angle β | | 19.5283° (right-handed) | |
| | Designation | | ZST 400-334-1000-R11; optionally with INIRA® | |
| Lubrication system ⁴⁾ | Set consisting of lubrication pinion and axis for | Rack | LMT 400-PU -18L1-040-1 | |
| | | Pinion | LMT 400-PU -18R1-040-1 | |
| | Lubricator | 125 cm ³ | LUC+125-0511-02 | |
| | | 400 cm ³ | LUC+400-0511-02 | |
| Lubricant | | WITTENSTEIN alpha G11 | | |

¹⁾ Maximum feed force depending on ratio and number of stages

²⁾ Calculation with lowest ratio and maximum input speed

³⁾ Single-stage also available

⁴⁾ Impulse-controlled basic version with one output and 2 m hose. See page 116 for further information on the lubrication system.

Application-specific dimensioning with cymex® – www.wittenstein-cymex.com

Alternative system solutions

| Pinion | | | Axis distance | RP+ 040S | RPM+ 040S | RPC+ 040S | RPK+ 040S | Rack |
|----------------------|-------------|------------|---------------|-----------------|-----------------|-----------------|-----------------|---|
| Designation | d [mm] | x [] | A [mm] | F_{zT} [N] | F_{zT} [N] | F_{zT} [N] | F_{zT} [N] | Designation |
| RMW 300-444-20L1-055 | 63.662 | 0.4 | 59.031 | 20300 | 20300 | 20300 | 20300 | ZST 300-334-1000-R11; optionally with INIRA® |
| RMW 300-444-34L1-073 | 108.226 | 0 | 80.113 | 17500 | 17500 | 17500 | 17500 | ZST 300-334-1000-R11; optionally with INIRA® |
| RMW 400-444-20L1-073 | 84.882 | 0.2 | 78.241 | 22300 | 22300 | 22300 | 22300 | ZST 400-334-1000-R11; optionally with INIRA® |
| RMW 400-444-24L1-073 | 101.859 | 0 | 85.930 | 18600 | 18600 | 18600 | 18600 | ZST 400-334-1000-R11; optionally with INIRA® |
| RMW 500-444-19L1-073 | 100.798 | 0.4 | 86.399 | 18800 | 18800 | 18800 | 18800 | ZST 500-332-1000-R1; optionally with INIRA® |

d = Pitch circle diameter

x = Addendum modification coefficient

A = Distance between pinion axle and rear surface of rack

F_{zT} = Maximum feed force depending on ratio and number of stages

RPM+ available in customized version

Application-specific dimensioning with cymex® – www.wittenstein-cymex.com

2-stage

up to 24⁴⁾ (G)
clamping hub
diameters

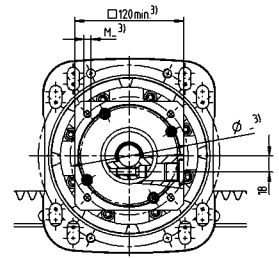
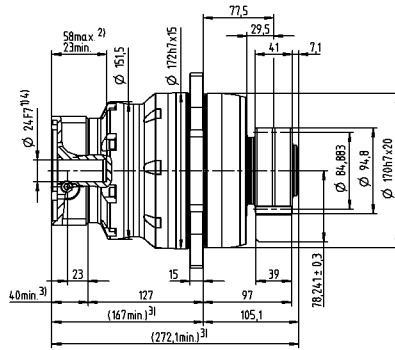
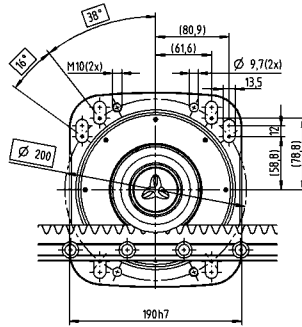

up to 38⁴⁾ (K)
clamping hub
diameters

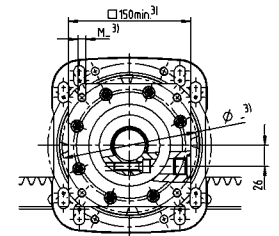
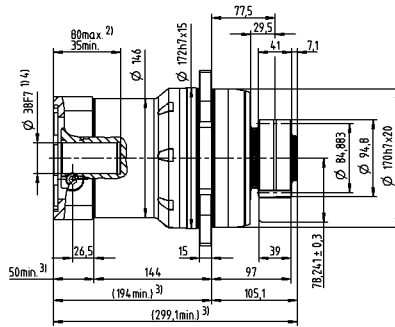
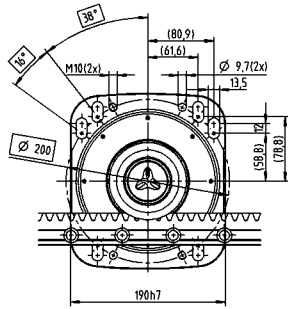

3-stage

up to 24⁴⁾ (G)
clamping hub
diameters

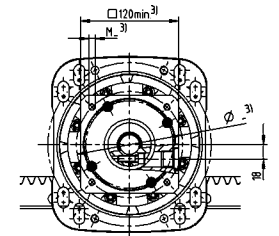
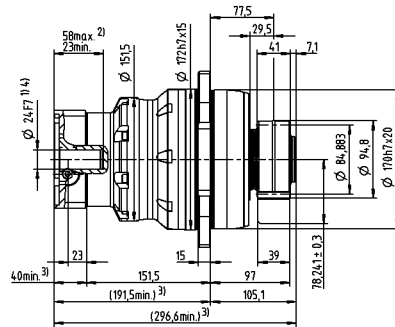
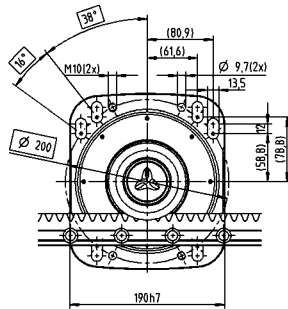

Motor shaft diameter [mm]

Premium Linear
Systems

Non-tolerated dimensions are nominal dimensions
Detailed rack dimensions starting on page 151
1) Check motor shaft fit
2) Min./Max. permissible motor shaft length. Longer motor shafts are possible, please contact alpha.
3) The dimensions depend on the motor
4) Smaller motor shaft diameter is compensated by a bushing with a minimum thickness of 1 mm

Premium Linear System PLS 36 with RP+

Planetary gearbox RP+ 050 MA with rack module 4 and pinion RMW module 4

| | | | | |
|---|---|-----------------------|--|---------------------------|
| System | Max. feed force ¹⁾ F_{2T} | | 36100 N | |
| | Max. feed speed ²⁾ v_{max} | | 112 m/min | 27 m/min |
| Gearbox | No. of stages ³⁾ | | 2 | 3 |
| | Ratios i | | 16 / 22 / 27.5 / 38.5 / 55 | 66 / 88 / 110 / 154 / 220 |
| | Clamping hub diameter | | 38 / 48 mm | 38 mm |
| | Designation | | RP 050S-MA2-_-_-_-3_-_- | RP 050S-MA3-_-_-_-3_-_- |
| Pinion | Module m | | 4 mm | |
| | Number of teeth z | | 24 | |
| | Pitch circle diameter d | | 101.859 mm | |
| | Profile correction factor x | | 0 | |
| | Helix angle β | | -19.5283° (left-handed) | |
| | Designation | | RMW 400-444-24L1-089 | |
| Rack | Module m | | 4 mm | |
| | Lengths L | | 1000 mm (493 mm) | |
| | Helix angle β | | 19.5283° (right-handed) | |
| | Designation | | ZST 400-334-1000-R11; optionally with INIRA® | |
| Lubrication system ⁴⁾ | Set consisting of lubrication pinion and axis for | Rack | LMT 400-PU -18L1-040-1 | |
| | | Pinion | LMT 400-PU -18R1-040-1 | |
| | Lubricator | 125 cm ³ | LUC+125-0511-02 | |
| | | 400 cm ³ | LUC+400-0511-02 | |
| Lubricant | | WITTENSTEIN alpha G11 | | |

¹⁾ Maximum feed force depending on ratio and number of stages

²⁾ Calculation with lowest ratio and maximum input speed

³⁾ Single-stage also available

⁴⁾ Impulse-controlled basic version with one output and 2 m hose. See page 116 for further information on the lubrication system.

Application-specific dimensioning with cymex® – www.wittenstein-cymex.com

Alternative system solutions

| Pinion | | | Axis distance | RP+ 050S | RPM+ 050S | RPC+ 050S | RPK+ 050S | Rack |
|----------------------|-------------|------------|---------------|-----------------|-----------------|-----------------|-----------------|---|
| Designation | d [mm] | x [] | A [mm] | F_{2T} [N] | F_{2T} [N] | F_{2T} [N] | F_{2T} [N] | Designation |
| RMW 400-444-24L1-089 | 101.859 | 0 | 85.930 | 36100 | 36100 | 36100 | 36100 | ZST 400-334-1000-R11; optionally with INIRA® |
| RMW 400-444-30L1-089 | 127.324 | 0 | 98.662 | 31300 | 31300 | 31300 | 31300 | ZST 400-334-1000-R11; optionally with INIRA® |
| RMW 500-444-19L1-089 | 100.798 | 0.4 | 86.399 | 36300 | 36300 | 36300 | 36300 | ZST 500-334-1000-R11; optionally with INIRA® |
| RMW 500-444-23L1-106 | 122.019 | 0 | 95.009 | 47000 | 47000 | 47000 | 47000 | ZST 500-334-1000-R11; optionally with INIRA® |
| RMW 500-444-30L1-106 | 159.155 | 0 | 113.578 | 38800 | 38800 | 38800 | 38800 | ZST 500-334-1000-R11; optionally with INIRA® |
| RMW 600-444-19L1-106 | 120.958 | 0.4 | 105.879 | 47200 | 47200 | 47200 | 47200 | ZST 600-334-1000-R11; optionally with INIRA® |
| RMW 600-444-23L1-106 | 146.423 | 0 | 116.211 | 41400 | 41400 | 41400 | 41400 | ZST 600-333-1000-R1; optionally with INIRA® |
| RMW 600-444-28L1-106 | 178.254 | 0 | 132.127 | 34600 | 34600 | 34600 | 34600 | ZST 600-333-1000-R1; optionally with INIRA® |

d = Pitch circle diameter

x = Addendum modification coefficient

A = Distance between pinion axle and rear surface of rack

F_{2T} = Maximum feed force depending on ratio and number of stages

RPM+ available in customized version

Application-specific dimensioning with cymex® – www.wittenstein-cymex.com

2-stage

up to 38⁴⁾ (K)
clamping hub
diameters

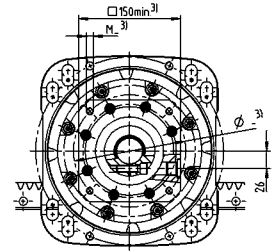
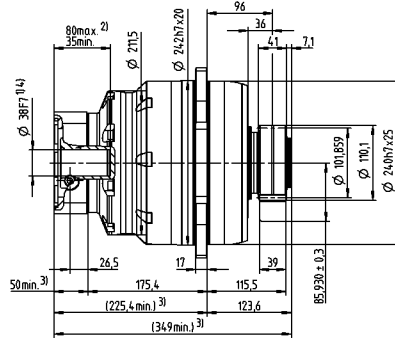
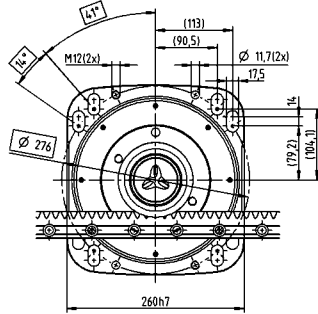

up to 48⁴⁾ (M)
clamping hub
diameters

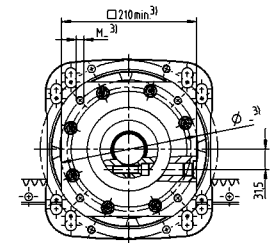
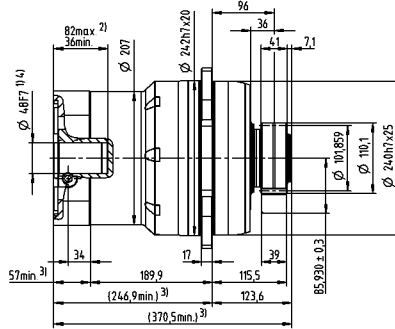
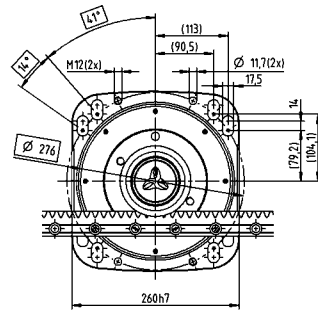

3-stage

up to 38⁴⁾ (K)
clamping hub
diameters

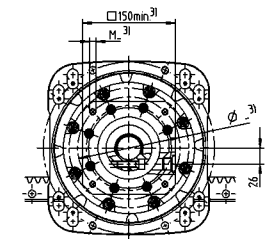
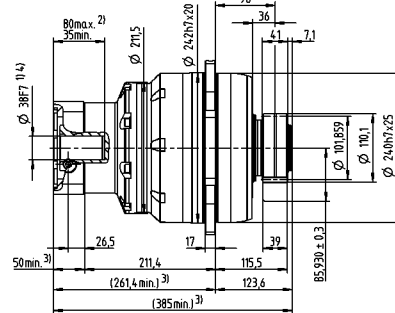
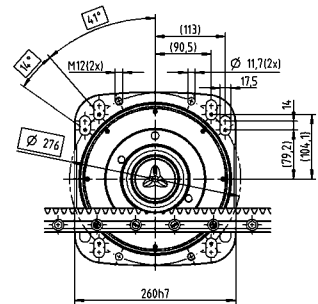

Motor shaft diameter [mm]

Non-tolerated dimensions are nominal dimensions
Detailed rack dimensions starting on page 151

¹⁾ Check motor shaft fit

²⁾ Min./Max. permissible motor shaft length. Longer motor shafts are possible, please contact alpha.

³⁾ The dimensions depend on the motor

⁴⁾ Smaller motor shaft diameter is compensated by a bushing with a minimum thickness of 1 mm

Premium Linear System PLS 47 with RP+

Planetary gearbox RP+ 050 MA with rack module 5 and pinion RMW module 5

| | | | | |
|---|---|-----------------------|--|---------------------------|
| System | Max. feed force ¹⁾ F_{2T} | | 47000 N | |
| | Max. feed speed ²⁾ v_{max} | | 135 m/min | 33 m/min |
| Gearbox | No. of stages ³⁾ | | 2 | 3 |
| | Ratios i | | 22 / 27.5 / 38.5 / 55 | 66 / 88 / 110 / 154 / 220 |
| | Clamping hub diameter | | 38 / 48 mm | 38 mm |
| | Designation | | RP 050S-MA2-_-_-_-3_-_- | RP 050S-MA3-_-_-_-3_-_- |
| Pinion | Module m | | 5 mm | |
| | Number of teeth z | | 23 | |
| | Pitch circle diameter d | | 122.019 mm | |
| | Profile correction factor x | | 0 | |
| | Helix angle β | | -19.5283° (left-handed) | |
| | Designation | | RMW 500-444-23L1-106 | |
| Rack | Module m | | 5 mm | |
| | Lengths L | | 1000 mm (500 mm) | |
| | Helix angle β | | 19.5283° (right-handed) | |
| | Designation | | ZST 500-334-1000-R11; optionally with INIRA® | |
| Lubrication system ⁴⁾ | Set consisting of lubrication pinion and axis for | Rack | LMT 500-PU -17L1-050-1 | |
| | | Pinion | LMT 500-PU -17R1-050-1 | |
| | Lubricator | 125 cm ³ | LUC+125-0511-02 | |
| | | 400 cm ³ | LUC+400-0511-02 | |
| Lubricant | | WITTENSTEIN alpha G11 | | |

¹⁾ Maximum feed force depending on ratio and number of stages

²⁾ Calculation with lowest ratio and maximum input speed

³⁾ Single-stage also available

⁴⁾ Impulse-controlled basic version with one output and 2 m hose. See page 116 for further information on the lubrication system.

Application-specific dimensioning with cymex® – www.wittenstein-cymex.com

Alternative system solutions

| Pinion | | | Axis distance | RP+ 050S | RPM+ 050S | RPC+ 050S | RPK+ 050S | Rack |
|----------------------|-------------|------------|---------------|-----------------|-----------------|-----------------|-----------------|---|
| Designation | d [mm] | x [] | A [mm] | F_{2T} [N] | F_{2T} [N] | F_{2T} [N] | F_{2T} [N] | Designation |
| RMW 400-444-24L1-089 | 101.859 | 0 | 85.930 | 36100 | 36100 | 36100 | 36100 | ZST 400-334-1000-R11; optionally with INIRA® |
| RMW 400-444-30L1-089 | 127.324 | 0 | 98.662 | 31300 | 31300 | 31300 | 31300 | ZST 400-334-1000-R11; optionally with INIRA® |
| RMW 500-444-19L1-089 | 100.798 | 0.4 | 86.399 | 36300 | 36300 | 36300 | 36300 | ZST 500-334-1000-R11; optionally with INIRA® |
| RMW 500-444-23L1-106 | 122.019 | 0 | 95.009 | 47000 | 47000 | 47000 | 47000 | ZST 500-334-1000-R11; optionally with INIRA® |
| RMW 500-444-30L1-106 | 159.155 | 0 | 113.578 | 38800 | 38800 | 38800 | 38800 | ZST 500-334-1000-R11; optionally with INIRA® |
| RMW 600-444-19L1-106 | 120.958 | 0.4 | 105.879 | 47200 | 47200 | 47200 | 47200 | ZST 600-334-1000-R11; optionally with INIRA® |
| RMW 600-444-23L1-106 | 146.423 | 0 | 116.211 | 41400 | 41400 | 41400 | 41400 | ZST 600-333-1000-R1; optionally with INIRA® |
| RMW 600-444-28L1-106 | 178.254 | 0 | 132.127 | 34600 | 34600 | 34600 | 34600 | ZST 600-333-1000-R1; optionally with INIRA® |

d = Pitch circle diameter

x = Addendum modification coefficient

A = Distance between pinion axle and rear surface of rack

F_{2T} = Maximum feed force depending on ratio and number of stages

RPM+ available in customized version

Application-specific dimensioning with cymex® – www.wittenstein-cymex.com

2-stage

up to 38⁴⁾ (K)
clamping hub
diameters

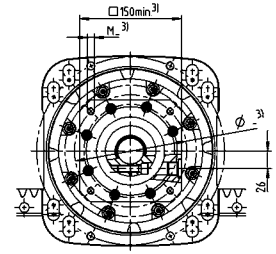
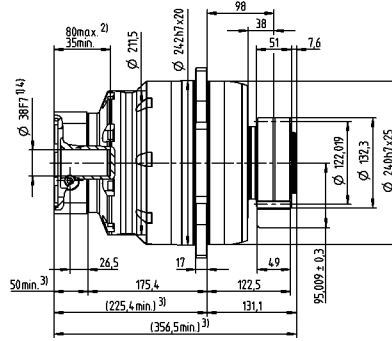
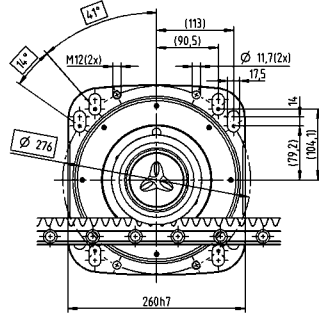

up to 48⁴⁾ (M)
clamping hub
diameters

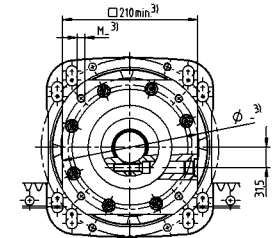
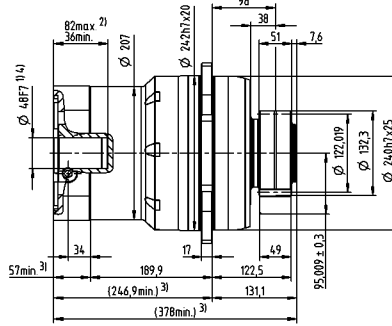
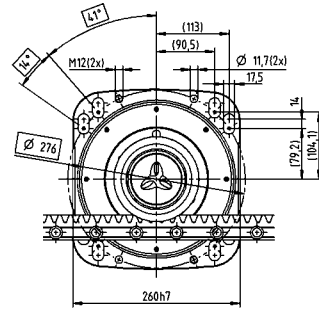

3-stage

up to 38⁴⁾ (K)
clamping hub
diameters

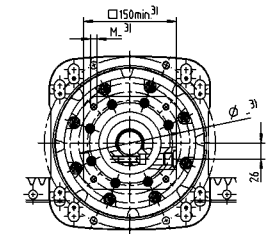
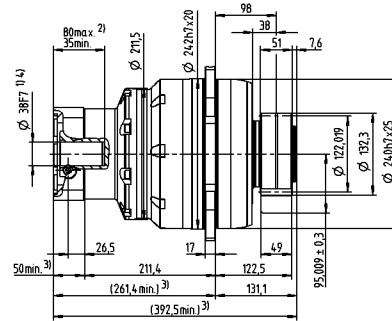
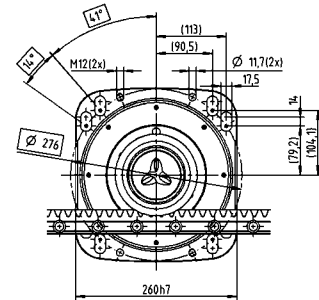

Motor shaft diameter [mm]

Premium Linear
Systems

Non-tolerated dimensions are nominal dimensions
Detailed rack dimensions starting on page 151

¹⁾ Check motor shaft fit

²⁾ Min./Max. permissible motor shaft length. Longer motor shafts are possible, please contact alpha.

³⁾ The dimensions depend on the motor

⁴⁾ Smaller motor shaft diameter is compensated by a bushing with a minimum thickness of 1 mm

Premium Linear System PLS 75 with RP+

Planetary gearbox RP+ 060 MA with rack module 6 and pinion RMW module 6

| | | | | |
|---|---|-----------------------|--|---------------------------|
| System | Max. feed force ¹⁾ F_{2T} | | 75000 N | |
| | Max. feed speed ²⁾ v_{max} | | 91 m/min | 30 m/min |
| Gearbox | No. of stages ³⁾ | | 2 | 3 |
| | Ratios i | | 22 / 27.5 / 38.5 / 55 | 66 / 88 / 110 / 154 / 220 |
| | Clamping hub diameter | | 48 mm | 38 mm |
| | Designation | | RP 060S-MA2-_-_-_-3_ _ | RP 060S-MA3-_-_-_-3_ _ |
| Pinion | Module m | | 6 mm | |
| | Number of teeth z | | 23 | |
| | Pitch circle diameter d | | 146.423 mm | |
| | Profile correction factor x | | 0 | |
| | Helix angle β | | -19.5283° (left-handed) | |
| | Designation | | RMW 600-444-23L1-128 | |
| Rack | Module m | | 6 mm | |
| | Lengths L | | 1000 mm (500 mm) | |
| | Helix angle β | | 19.5283° (right-handed) | |
| | Designation | | ZST 600-334-1000-R11; optionally with INIRA® | |
| Lubrication system ⁴⁾ | Set consisting of lubrication pinion and axis for | Rack | LMT 600-PU -17L1-060-1 | |
| | | Pinion | LMT 600-PU -17R1-060-1 | |
| | Lubricator | 125 cm ³ | LUC+125-0511-02 | |
| | | 400 cm ³ | LUC+400-0511-02 | |
| Lubricant | | WITTENSTEIN alpha G11 | | |

¹⁾ Maximum feed force depending on ratio and number of stages

²⁾ Calculation with lowest ratio and maximum input speed

³⁾ Single-stage also available

⁴⁾ Impulse-controlled basic version with one output and 2 m hose. See page 116 for further information on the lubrication system.

Application-specific dimensioning with cymex® – www.wittenstein-cymex.com

Alternative system solutions

| Pinion | | | Axis distance | RP+ 060S | RPM+ 060S | RPC+ 060S | RPK+ 060S | Rack |
|----------------------|-------------|------------|---------------|-----------------|-----------------|-----------------|-----------------|---|
| Designation | d [mm] | x [] | A [mm] | F_{2T} [N] | F_{2T} [N] | F_{2T} [N] | F_{2T} [N] | Designation |
| RMW 500-444-23L1-106 | 122.019 | 0 | 95.009 | 47000 | 47000 | 47000 | 47000 | ZST 500-334-1000-R11; optionally with INIRA® |
| RMW 500-444-30L1-106 | 159.155 | 0 | 113.578 | 39400 | 39400 | 39400 | 39400 | ZST 500-334-1000-R11; optionally with INIRA® |
| RMW 600-444-19L1-106 | 120.958 | 0.4 | 105.879 | 47200 | 47200 | 47200 | 47200 | ZST 600-333-1000-R11; optionally with INIRA® |
| RMW 600-444-23L1-128 | 146.423 | 0 | 116.211 | 75000 | 75000 | 75000 | 75000 | ZST 600-334-1000-R11; optionally with INIRA® |
| RMW 600-444-28L1-128 | 178.254 | 0 | 132.127 | 61500 | 61500 | 61500 | 61500 | ZST 600-334-1000-R11; optionally with INIRA® |

d = Pitch circle diameter

x = Addendum modification coefficient

A = Distance between pinion axle and rear surface of rack

F_{2T} = Maximum feed force depending on ratio and number of stages

RPM+ available in customized version

Application-specific dimensioning with cymex® – www.wittenstein-cymex.com

Premium Linear System PLS 112 with RP+

Planetary gearbox RP+ 080 MA with rack module 8 and pinion RMW module 8

| | | | | |
|---|---|---------------------|--|---------------------------|
| System | Max. feed force ¹⁾ F_{2T} | | 112000 N | |
| | Max. feed speed ²⁾ v_{max} | | 111 m/min | 37 m/min |
| Gearbox | No. of stages ³⁾ | | 2 | 3 |
| | Ratios i | | 22 / 27.5 / 38.5 / 55 | 66 / 88 / 110 / 154 / 220 |
| | Clamping hub diameter | | 48 mm | 38 / 48 mm |
| | Designation | | RP 080S-MA2-_-_-_-3_ _ | RP 080S-MA3-_-_-_-3_ _ |
| Pinion | Module m | | 8 mm | |
| | Number of teeth z | | 21 | |
| | Pitch circle diameter d | | 178.254 mm | |
| | Profile correction factor x | | 0.2 | |
| | Helix angle β | | -19.5283° (left-handed) | |
| | Designation | | RMW 800-444-21L1-156 | |
| Rack | Module m | | 8 mm | |
| | Lengths L | | 960 mm | |
| | Helix angle β | | 19.5283° (right-handed) | |
| | Designation | | ZST 800-334- 960-R11; optionally with INIRA® | |
| Lubrication system ⁴⁾ | Set consisting of lubrication pinion and axis for | Rack | LMT 800-PU -17L1-080-1 | |
| | | Pinion | LMT 800-PU -17R1-080-1 | |
| | Lubricator | 125 cm ³ | LUC+125-0511-02 | |
| | | 400 cm ³ | LUC+400-0511-02 | |
| | Lubricant | | WITTENSTEIN alpha G11 | |

¹⁾ Maximum feed force depending on ratio and number of stages

²⁾ Calculation with lowest ratio and maximum input speed

³⁾ Single-stage also available

⁴⁾ Impulse-controlled basic version with one output and 2 m hose. See page 116 for further information on the lubrication system.

Application-specific dimensioning with cymex® – www.wittenstein-cymex.com

Alternative system solutions

| Pinion | | | Axis distance | RP+ 080S | RPM+ 080S | RPC+ 080S | RPK+ 080S | Rack |
|----------------------|-------------|------------|---------------|-----------------|-----------------|-----------------|-----------------|---|
| Designation | d [mm] | x [] | A [mm] | F_{2T} [N] | F_{2T} [N] | F_{2T} [N] | F_{2T} [N] | Designation |
| RMW 600-444-23L1-128 | 146.423 | 0 | 116.211 | 75000 | 75000 | 75000 | 75000 | ZST 600-334-1000-R11; optionally with INIRA® |
| RMW 600-444-28L1-128 | 178.254 | 0 | 132.127 | 64500 | 64500 | 64500 | 64500 | ZST 600-334-1000-R11; optionally with INIRA® |
| RMW 800-444-21L1-156 | 178.254 | 0.2 | 161.727 | 112000 | 112000 | 112000 | 112000 | ZST 800-334- 960-R11; optionally with INIRA® |

d = Pitch circle diameter

x = Addendum modification coefficient

A = Distance between pinion axle and rear surface of rack

F_{2T} = Maximum feed force depending on ratio and number of stages

RPM+ available in customized version

Application-specific dimensioning with cymex® – www.wittenstein-cymex.com

2-stage

up to 48⁴⁾ (M)
clamping hub
diameters

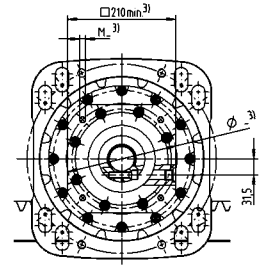
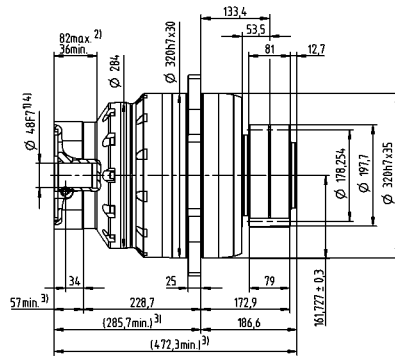
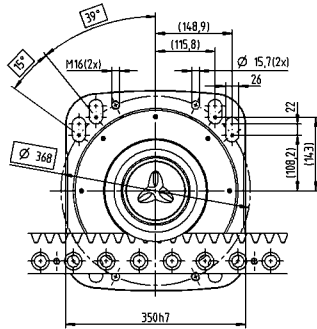

3-stage

up to 38⁴⁾ (K)
clamping hub
diameters

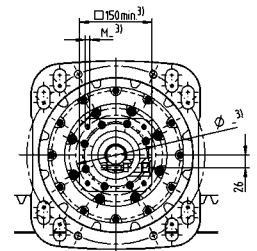
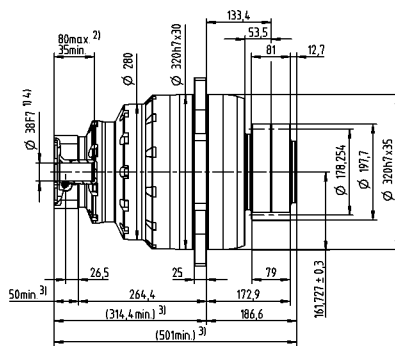
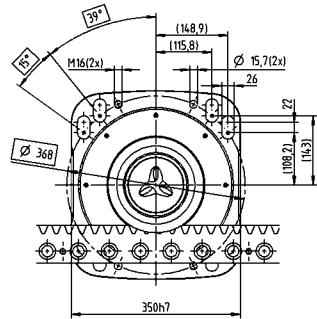

Motor shaft diameter [mm]

up to 48⁴⁾ (M)
clamping hub
diameters

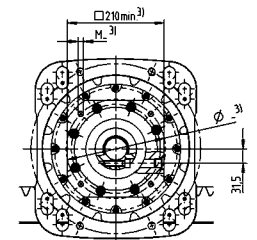
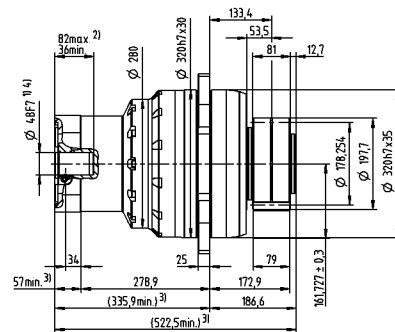
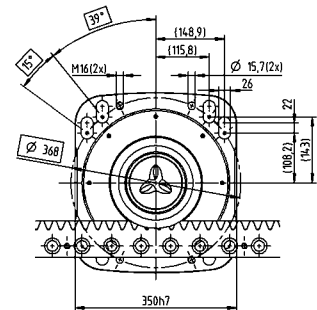

Non-tolerated dimensions are nominal dimensions
Detailed rack dimensions starting on page 151

¹⁾ Check motor shaft fit

²⁾ Min./Max. permissible motor shaft length. Longer motor shafts are possible, please contact alpha.

³⁾ The dimensions depend on the motor

⁴⁾ Smaller motor shaft diameter is compensated by a bushing with a minimum thickness of 1 mm

Rotary systems with straight tothing

Know-how of linear technology for rotary applications

Applications for gearboxes with a straight-toothed output pinion can be found where smooth operation has a low priority, axial forces generated by helical teeth should be prevented, or a straight-toothed mating gear such as a gear ring is already chosen. We now offer an extensive portfolio for such applications. Depending on the requirements regarding positionong

accuracy and feed force one can choose between a variety of alternative solutions. You can create the perfect drive configuration quickly and easily using the new "gear ring" module in cymex®. Drives with a straight-toothed output pinion are not only suitable for gear rings, they can also be used in combination with straight-toothed racks.

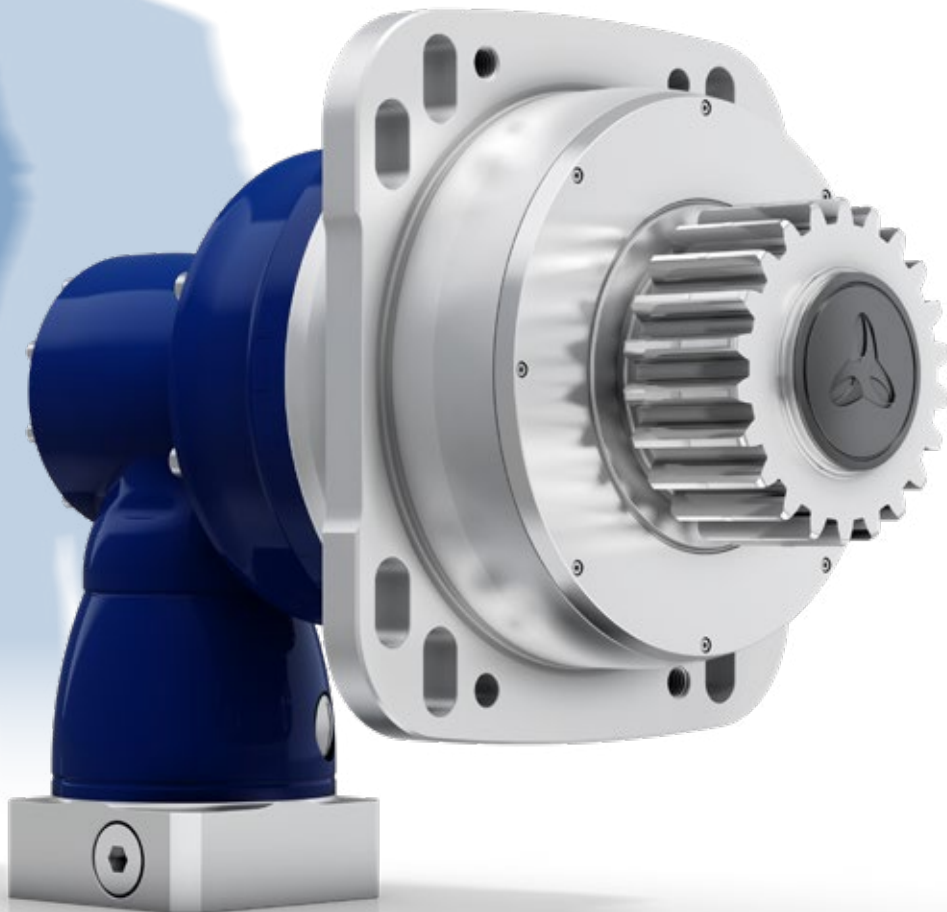

RPK+ with straight-toothed output pinion

Bed-type milling machine

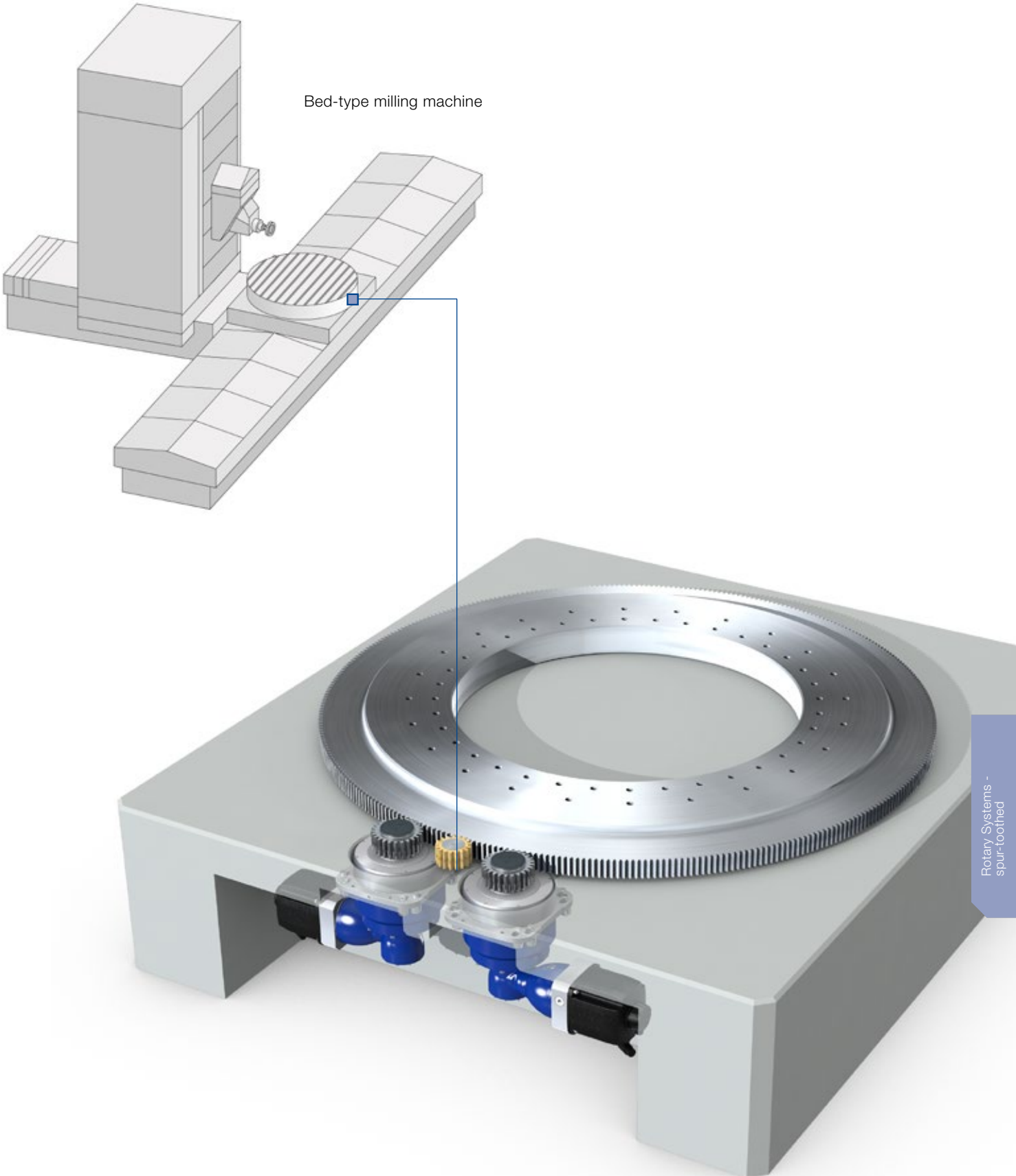

Rotary systems with straight toothing – Value Segment

NPR, NPS and NPL with straight-toothed RMK preferred pinion

| | NPR / NPS / NPL | | | | Set consisting of lubrication pinion and axis ¹⁾ |
|--------------------------|-------------------|-------------------|-------------------|-------------------|---|
| | 015 | 025 | 035 | 045 | |
| Pinion | F_{2T}^* [N] | F_{2T}^* [N] | F_{2T}^* [N] | F_{2T}^* [N] | Ordering code |
| Ordering code | | | | | |
| RMK 150-222-20G0-016-022 | 1990 | | | | LMT 150-PU -24G0-020-1 |
| RMK 200-222-19G0-016-019 | 2100 | | | | LMT 200-PU -17G0-020-1 |
| RMK 200-222-22G0-022-020 | | 3400 | | | LMT 200-PU -17G0-020-1 |
| RMK 300-222-22G0-032-019 | | | 6170 | | LMT 300-PU -17G0-030-1 |
| RMK 300-222-25G0-040-036 | | | | 9300 | LMT 300-PU -17G0-030-1 |
| RMK 400-222-20G0-040-036 | | | | 9300 | LMT 400-PU -17G0-040-1 |

* F_{2T} Tangential force / feed force – adhere to the permissible tangential force of mating gear

1) See page 116 for further information on the lubricator and lubrication system

Application-specific dimensioning with cymex® – www.wittenstein-cymex.com

NP with straight-toothed RMK preferred pinion

| | NP | | | | Set consisting of lubrication pinion and axis ¹⁾ |
|--------------------------|-------------------|-------------------|-------------------|-------------------|---|
| | 015 | 025 | 035 | 045 | |
| Pinion | F_{2T}^* [N] | F_{2T}^* [N] | F_{2T}^* [N] | F_{2T}^* [N] | Ordering code |
| Ordering code | | | | | |
| RMK 150-222-20G0-016-022 | 1160 | | | | LMT 150-PU -24G0-020-1 |
| RMK 200-222-19G0-016-019 | 2100 | | | | LMT 200-PU -17G0-020-1 |
| RMK 200-222-22G0-022-020 | | 2020 | | | LMT 200-PU -17G0-020-1 |
| RMK 300-222-22G0-032-019 | | | 4680 | | LMT 300-PU -17G0-030-1 |
| RMK 300-222-25G0-040-036 | | | | 7450 | LMT 300-PU -17G0-030-1 |
| RMK 400-222-20G0-040-036 | | | | 7450 | LMT 400-PU -17G0-040-1 |

* F_{2T} Tangential force / feed force – adhere to the permissible tangential force of mating gear

1) See page 116 for further information on the lubricator and lubrication system

Application-specific dimensioning with cymex® – www.wittenstein-cymex.com

| Pinion designation | Gearbox size | m [mm] | z [] | x [] | d [mm] | d_a [mm] | $A \pm 0.3$ [mm] | b [mm] | B [mm] | L_{12} [mm] | L_{13} [mm] | L_{15} [mm] | L_{16} [mm] | L_{17} [mm] | l_{Fq} [mm] |
|--------------------------|--------------|-------------|------------|------------|-------------|---------------|---------------------|-------------|-------------|------------------|------------------|------------------|------------------|------------------|------------------|
| RMK 150-222-20G0-016-022 | NPR 015S* | 1.5 | 20 | 0.3 | 30 | 33.9 | 32.95 | 21 | 19 | 54 | 41.5 | 12 | 32 | 2 | 21.5 |
| RMK 200-222-19G0-016-019 | NPR 015S* | 2 | 19 | 0.4 | 38 | 43.6 | 41.8 | 26 | 24 | 54 | 39 | 7 | 27 | 2 | 19 |
| RMK 200-222-22G0-022-020 | NPR 025S* | 2 | 22 | 0 | 44 | 48 | 44 | 26 | 24 | 62 | 40 | 8 | 28 | 9 | 20 |
| RMK 300-222-22G0-032-019 | NPR 035S* | 3 | 22 | 0 | 66 | 71.9 | 59 | 31 | 29 | 95.5 | 48.5 | 4 | 34 | 31.5 | 18.5 |
| RMK 300-222-25G0-040-036 | NPR 045S* | 3 | 25 | 0 | 75 | 80.9 | 63.5 | 31 | 29 | 122 | 65.5 | 21 | 51 | 41 | 35.5 |
| RMK 400-222-20G0-040-036 | NPR 045S* | 4 | 20 | 0 | 80 | 87.9 | 75 | 41 | 39 | 122 | 65.5 | 16 | 46 | 36 | 35.5 |

* also applies to NPS

m = Module

z = Number of teeth

d = Pitch circle diameter

x = Addendum modification coefficient

d_a = Tip diameter

Refer to the respective gearbox catalog for the exact gearbox dimensions.

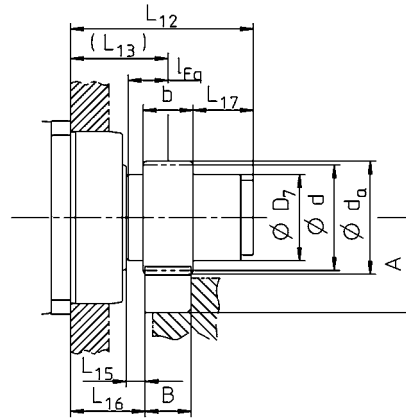

| Pinion designation | Gearbox size | m [mm] | z [] | x [] | d [mm] | d_a [mm] | $A \pm 0.3$ [mm] | b [mm] | B [mm] | L_{12} [mm] | L_{13} [mm] | L_{15} [mm] | L_{16} [mm] | L_{17} [mm] | l_{Fq} [mm] |
|--------------------------|--------------|-------------|------------|------------|-------------|---------------|---------------------|-------------|-------------|------------------|------------------|------------------|------------------|------------------|------------------|
| RMK 150-222-20G0-016-022 | NP 015S | 1.5 | 20 | 0.3 | 30 | 33.9 | 32.95 | 21 | 19 | 42 | 29.5 | 12 | 20 | 2 | 21.5 |
| RMK 200-222-19G0-016-019 | NP 015S | 2 | 19 | 0.4 | 38 | 43.6 | 41.8 | 26 | 24 | 42 | 27 | 7 | 15 | 2 | 19 |
| RMK 200-222-22G0-022-020 | NP 025S | 2 | 22 | 0 | 44 | 48 | 44 | 26 | 24 | 52 | 30 | 8 | 18 | 9 | 20 |
| RMK 300-222-22G0-032-019 | NP 035S | 3 | 22 | 0 | 66 | 71.9 | 59 | 31 | 29 | 77.5 | 30.5 | 4 | 16 | 31.5 | 18.5 |
| RMK 300-222-25G0-040-036 | NP 045S | 3 | 25 | 0 | 75 | 80.9 | 63.5 | 31 | 29 | 107 | 50.5 | 21 | 36 | 41 | 35.5 |
| RMK 400-222-20G0-040-036 | NP 045S | 4 | 20 | 0 | 80 | 87.9 | 75 | 41 | 39 | 107 | 50.5 | 16 | 31 | 36 | 35.5 |

m = Module

z = Number of teeth

d = Pitch circle diameter

x = Profile correction factor

d_a = Tip diameter

Refer to the respective gearbox catalog for the exact gearbox dimensions.

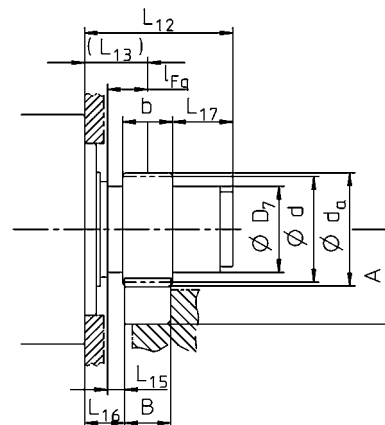

Rotary systems with straight tothing – Advanced Segment

SP⁺, SK⁺, SPK⁺ and SPC⁺ with straight-toothed RMS preferred pinion

| Pinion | SP ⁺ / SK ⁺ / SPK ⁺ / SPC ⁺ | | | | | Set consisting of lubrication pinion and axis ¹⁾ |
|----------------------|---|-------------------|-------------------|-------------------|-------------------|---|
| | 060 ²⁾ | 075 | 100 | 140 | 180 | |
| Ordering code | F_{2T}^* [N] | F_{2T}^* [N] | F_{2T}^* [N] | F_{2T}^* [N] | F_{2T}^* [N] | Ordering code |
| RMS 200-323-16G0-016 | 2320 | | | | | LMT 200-PU -17G0-020-1 |
| RMS 200-323-19G0-022 | | 3410 | | | | LMT 200-PU -17G0-020-1 |
| RMS 300-323-17G0-032 | | | 6170 | | | LMT 300-PU -17G0-030-1 |
| RMS 300-323-22G0-040 | | | | 9040 | | LMT 300-PU -17G0-030-1 |
| RMS 400-323-19G0-040 | | | | 9260 | | LMT 400-PU -17G0-040-1 |
| RMS 400-323-22G0-055 | | | | | 13300 | LMT 400-PU -17G0-040-1 |
| RMS 500-323-19G0-055 | | | | | 13900 | LMT 500-PU -17G0-050-1 |

* F_{2T} Tangential force / feed force – adhere to the permissible tangential force of mating gear

1) See page 116 for further information on the lubricator and lubrication system

2) not with SPK⁺

Also available with V-Drive VT⁺

Application-specific dimensioning with cymex® – www.wittenstein-cymex.com

TP⁺, TK⁺, TPK⁺ and TPC⁺ with straight-toothed RMF preferred pinion

| Pinion | TP ⁺ / TK ⁺ / TPK ⁺ / TPC ⁺ | | | | | Set consisting of lubrication pinion and axis ¹⁾ |
|------------------------------|---|-------------------|-------------------|-------------------|-------------------------------------|---|
| | 010 | 025 | 050 | 110 | TP ⁺ 4000 HIGH TORQUE | |
| Ordering code | F_{2T}^* [N] | F_{2T}^* [N] | F_{2T}^* [N] | F_{2T}^* [N] | F_{2T}^* [N] | Ordering code |
| RMF 200-443-36G0-050-8xM6 | 2640 | | | | | LMT 200-PU -17G0-020-1 |
| RMF 200-443-36G0-063-12xM6 | | 3500 | | | | LMT 200-PU -17G0-020-1 |
| RMF 300-443-37G0-080-12xM8 | | | 11500 | | | LMT 300-PU -17G0-030-1 |
| RMF 400-443-40G0-125-12xM10 | | | | 22400 | | LMT 400-PU -17G0-040-1 |
| RMF 1000-443-36G0-260-16xM30 | | | | | 176000 | LMT 1000-PU -17G0-100-1 |

* F_{2T} Tangential force / feed force – adhere to the permissible tangential force of mating gear

1) See page 116 for further information on the lubricator and lubrication system

Also available with V-Drive VT⁺

Application-specific dimensioning with cymex® – www.wittenstein-cymex.com

| Pinion designation | Gearbox size | m [mm] | z [] | x [] | d [mm] | d_a [mm] | $A \pm 0,3$ [mm] | b [mm] | B [mm] | L_{12} [mm] | L_{13} [mm] | L_{15} [mm] | L_{16} [mm] | l_{Fq} [mm] |
|----------------------|--------------|-------------|------------|------------|-------------|---------------|---------------------|-------------|-------------|------------------|------------------|------------------|------------------|------------------|
| RMS 200-323-16G0-016 | SP 060R* | 2 | 16 | 0.5 | 32 | 38.3 | 39 | 26 | 24 | 52 | 39 | 7 | 27 | 19 |
| RMS 200-323-19G0-022 | SP 075R* | 2 | 19 | 0.4 | 38 | 43.9 | 41.8 | 26 | 24 | 53 | 40 | 8 | 28 | 20 |
| RMS 300-323-17G0-032 | SP 100R* | 3 | 17 | 0.4 | 51 | 59.6 | 52.7 | 31 | 29 | 64 | 48.5 | 4 | 34 | 18.5 |
| RMS 300-323-22G0-040 | SP 140R* | 3 | 22 | 0.2 | 66 | 73.4 | 59.6 | 31 | 29 | 81 | 65.5 | 21 | 51 | 35.5 |
| RMS 400-323-19G0-040 | SP 140R* | 4 | 19 | 0.3 | 76 | 86.6 | 74.2 | 41 | 39 | 81 | 60.5 | 11 | 41 | 30.5 |
| RMS 400-323-22G0-055 | SP 180S* | 4 | 22 | 0.2 | 88 | 97.8 | 79.8 | 41 | 39 | 84 | 63.5 | 14 | 44 | 33.5 |
| RMS 500-323-19G0-055 | SP 180S* | 5 | 19 | 0.4 | 95 | 109.2 | 83.5 | 51 | 49 | 84 | 58.5 | 4 | 34 | 28.5 |

* also applies to SK⁺, SPK⁺, SPC⁺

m = Module

z = Number of teeth

d = Pitch circle diameter

x = Profile correction factor

d_a = Tip diameter

Refer to the respective gearbox catalog for the exact gearbox dimensions.

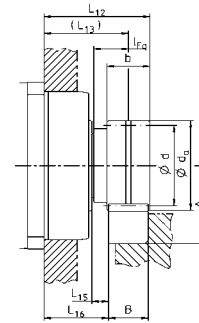

| Pinion designation | Gearbox size | m [mm] | z [] | x [] | d [mm] | d_a [mm] | $A \pm 0,3$ [mm] | b [mm] | B [mm] | L_{12} [mm] | L_{13} [mm] | L_{15} [mm] | L_{16} [mm] | l_{Fq} [mm] |
|------------------------------|--------------|-------------|------------|------------|-------------|---------------|---------------------|-------------|-------------|------------------|------------------|------------------|------------------|------------------|
| RMF 200-443-36G0-050-8xM6 | TP 010S-MF* | 2 | 36 | 0 | 72 | 76.2 | 48 | 26 | 24 | 56 | 43 | 1 | 31 | 13 |
| RMF 200-443-36G0-063-12xM6 | TP 025S-MF* | 2 | 36 | 0 | 72 | 76.2 | 48 | 26 | 24 | 65 | 52 | 11 | 40 | 23 |
| RMF 300-443-37G0-080-12xM8 | TP 050S-MF* | 3 | 37 | 0 | 111 | 117.2 | 81.5 | 31 | 29 | 69 | 53.5 | 1 | 39 | 15.5 |
| RMF 400-443-40G0-125-12xM10 | TP 110S-MF* | 4 | 40 | 0 | 160 | 168.2 | 115 | 41 | 39 | 91 | 70.5 | 1 | 51 | 20.5 |
| RMF 1000-443-36G0-260-16xM30 | TP 4000S-MA | 10 | 36 | 0 | 360 | 380.1 | 269 | 101 | 99 | 236 | 185.5 | 1 | 136 | 50.5 |

* also applies to TK⁺, TPK⁺, TPC⁺

m = Module

z = Number of teeth

d = Pitch circle diameter

x = Profile correction factor

d_a = Tip diameter

Refer to the respective gearbox catalog for the exact gearbox dimensions.

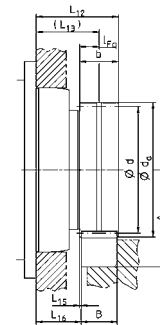

Rotary systems with straight toothing – Advanced Segment

TP+ and TPK+ HIGH TORQUE with straight-toothed RMW preferred pinion

| Pinion | TP+ / TPK+ HIGH TORQUE | | | | | | Set consisting of lubrication pinion and axis ¹⁾ |
|----------------------|------------------------|-------------------|-------------------|-------------------|-------------------|-------------------|---|
| | 010 ²⁾ | 025 | 050 | 110 | 300 | 500 | |
| Ordering code | F_{2T}^* [N] | F_{2T}^* [N] | F_{2T}^* [N] | F_{2T}^* [N] | F_{2T}^* [N] | F_{2T}^* [N] | Ordering code |
| RMW 200-444-22G0-037 | 3510 | | | | | | LMT 200-PU -17G0-020-1 |
| RMW 200-444-22G0-037 | | 4340 | | | | | LMT 200-PU -17G0-020-1 |
| RMW 300-444-21G0-055 | | 4200 | | | | | LMT 300-PU -17G0-030-1 |
| RMW 300-444-21G0-055 | | | 11400 | | | | LMT 300-PU -17G0-030-1 |
| RMW 400-444-22G0-073 | | | 10900 | | | | LMT 400-PU -17G0-040-1 |
| RMW 400-444-22G0-073 | | | | 21900 | | | LMT 400-PU -17G0-040-1 |
| RMW 500-444-21G0-089 | | | | 21200 | | | LMT 500-PU -17G0-050-1 |
| RMW 500-444-21G0-089 | | | | | 34000 | | LMT 500-PU -17G0-050-1 |
| RMW 600-444-20G0-106 | | | | | 33000 | | LMT 600-PU -17G0-060-1 |
| RMW 600-444-20G0-106 | | | | | | 44300 | LMT 600-PU -17G0-060-1 |
| RMW 800-444-19G0-128 | | | | | | 41500 | LMT 800-PU -17G0-080-1 |

* F_{2T} Tangential force / feed force – adhere to the permissible tangential force of mating gear

1) See page 116 for further information on the lubricator and lubrication system

2) not with TPK+

Also available with V-Drive VT+

Application-specific dimensioning with cymex® – www.wittenstein-cymex.com

| Pinion designation | Gearbox size | m [mm] | z [] | x [] | d [mm] | d_a [mm] | $A \pm 0,3$ [mm] | b [mm] | B [mm] | L_{12} [mm] | L_{13} [mm] | L_{15} [mm] | L_{16} [mm] | l_{Fg} [mm] |
|----------------------|--------------|-------------|------------|------------|-------------|---------------|---------------------|-------------|-------------|------------------|------------------|------------------|------------------|------------------|
| RMW 200-444-22G0-037 | TP 010S-MA* | 2 | 22 | 0.3 | 44 | 49.5 | 44.6 | 26 | 24 | 71 | 50.5 | 8.5 | 38.5 | 20.5 |
| RMW 200-444-22G0-037 | TP 025S-MA* | 2 | 22 | 0.3 | 44 | 49.5 | 44.6 | 26 | 24 | 73.5 | 53 | 12 | 41 | 24 |
| RMW 300-444-21G0-055 | TP 025S-MA* | 3 | 21 | 0.4 | 63 | 71.7 | 58.7 | 31 | 29 | 76 | 52.5 | 9 | 38 | 23.5 |
| RMW 300-444-21G0-055 | TP 050S-MA* | 3 | 21 | 0.4 | 63 | 71.7 | 58.7 | 31 | 29 | 89.5 | 66 | 13.5 | 51.5 | 28 |
| RMW 400-444-22G0-073 | TP 050S-MA* | 4 | 22 | 0.2 | 88 | 97.9 | 79.8 | 41 | 39 | 97 | 67.5 | 10 | 48 | 29.5 |
| RMW 400-444-22G0-073 | TP 110S-MA* | 4 | 22 | 0.2 | 88 | 97.9 | 79.8 | 41 | 39 | 112.5 | 83 | 13.5 | 63.5 | 33 |
| RMW 500-444-21G0-089 | TP 110S-MA* | 5 | 21 | 0.4 | 105 | 119.3 | 88.5 | 51 | 49 | 120 | 85 | 10.5 | 60.5 | 35 |
| RMW 500-444-21G0-089 | TP 300S-MA* | 5 | 21 | 0.4 | 105 | 119.3 | 88.5 | 51 | 49 | 139 | 104 | 13.5 | 79.5 | 38 |
| RMW 600-444-20G0-106 | TP 300S-MA* | 6 | 20 | 0.4 | 120 | 137.1 | 105.4 | 61 | 59 | 142.5 | 106 | 10.5 | 76.5 | 40 |
| RMW 600-444-20G0-106 | TP 500S-MA* | 6 | 20 | 0.4 | 120 | 137.1 | 105.4 | 81 | 59 | 155 | 118.5 | 14 | 89 | 43.5 |
| RMW 800-444-19G0-128 | TP 500S-MA* | 8 | 19 | 0.4 | 152 | 174.7 | 150.2 | 19 | 79 | 174 | 128.5 | 14 | 89 | 53.5 |

* also applies to TPK* HIGH TORQUE

m = Module

z = Number of teeth

d = Pitch circle diameter

x = Profile correction factor

d_a = Tip diameter

Refer to the respective gearbox catalog for the exact gearbox dimensions.

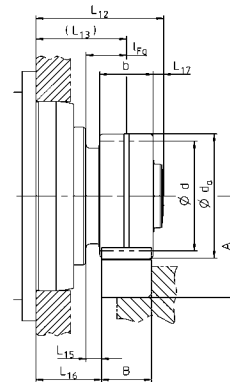

Rotary systems with straight tothing – Premium Segment

RP⁺, RPM⁺, RPK⁺ and RPC⁺ with straight-toothed RMW preferred pinion

| Pinion | RP ⁺ / RPM ⁺ / RPK ⁺ / RPC ⁺ | | | | | Set consisting of lubrication pinion and axis ¹⁾ |
|----------------------|--|-------------------|-------------------|-------------------|-------------------|---|
| | 30 | 40 | 50 | 60 | 80 | |
| Ordering code | F_{2T}^* [N] | F_{2T}^* [N] | F_{2T}^* [N] | F_{2T}^* [N] | F_{2T}^* [N] | Ordering code |
| RMW 200-444-22G0-037 | 9950 | – | – | – | – | LMT 200-PU -17G0-020-1 |
| RMW 300-444-21G0-055 | 13800 | – | – | – | – | LMT 300-PU -17G0-030-1 |
| RMW 300-444-21G0-055 | – | 20300 | – | – | – | LMT 300-PU -17G0-030-1 |
| RMW 400-444-22G0-073 | – | 21500 | – | – | – | LMT 400-PU -17G0-040-1 |
| RMW 500-444-21G0-073 | – | 18000 | – | – | – | LMT 500-PU -17G0-050-1 |
| RMW 500-444-25G0-106 | – | – | 47800 | – | – | LMT 500-PU -17G0-050-1 |
| RMW 600-444-20G0-106 | – | – | 48600 | – | – | LMT 600-PU -17G0-060-1 |
| RMW 600-444-25G0-128 | – | – | – | 73000 | – | LMT 600-PU -17G0-060-1 |
| RMW 800-444-19G0-128 | – | – | – | 69400 | – | LMT 800-PU -17G0-080-1 |
| RMW 800-444-23G0-156 | – | – | – | – | 108000 | LMT 800-PU -17G0-080-1 |

* F_{2T} Tangential force / feed force – adhere to the permissible tangential force of mating gear

1) See page 116 for further information on the lubricator and lubrication system

RPM⁺ available in customized version

Also available with V-Drive VT⁺

Application-specific dimensioning with cymex® – www.wittenstein-cymex.com

XP⁺, XPK⁺, XPC⁺ and PHG R with straight-toothed RMW preferred pinion

| Pinion | XP ⁺ / XPK ⁺ / XPC ⁺ | | | Set consisting of lubrication pinion and axis ¹⁾ |
|----------------------|---|-------------------|-------------------|---|
| | 020 | 030 | 040 | |
| Ordering code | F_{2T}^* [N] | F_{2T}^* [N] | F_{2T}^* [N] | Ordering code |
| RMW 200-444-22G0-033 | 5600 | – | – | LMT 200-PU -17G0-020-1 |
| RMW 200-444-22G0-037 | – | 8400 | – | LMT 300-PU -17G0-030-1 |
| RMW 300-444-21G0-037 | – | 7400 | – | LMT 300-PU -17G0-030-1 |
| RMW 300-444-21G0-055 | – | – | 10800 | LMT 300-PU -17G0-030-1 |
| RMW 400-444-22G0-055 | – | – | 10800 | LMT 400-PU -17G0-040-1 |
| | 2 | 3 | | |
| | PHG R | | | |

* F_{2T} Tangential force / feed force – adhere to the permissible tangential force of mating gear

1) See page 116 for further information on the lubricator and lubrication system

RPM⁺ available in customized version

Also available with V-Drive VT⁺

Application-specific dimensioning with cymex® – www.wittenstein-cymex.com

| Pinion designation | Gearbox size | <i>m</i> [mm] | <i>z</i> [] | <i>x</i> [] | <i>d</i> [mm] | <i>d_a</i> [mm] | <i>A</i> ± 0,3 [mm] | <i>b</i> [mm] | <i>B</i> [mm] | <i>L₁₂</i> [mm] | <i>L₁₃</i> [mm] | <i>L₁₅</i> [mm] | <i>L₁₆</i> [mm] | <i>L₁₇</i> [mm] | <i>I_{Fq}</i> [mm] |
|----------------------|--------------|------------------|-----------------|-----------------|------------------|------------------------------|------------------------|------------------|------------------|-------------------------------|-------------------------------|-------------------------------|-------------------------------|-------------------------------|-------------------------------|
| RMW 200-444-22G0-037 | RP 030S* | 2 | 22 | 0.3 | 44 | 49.5 | 44.6 | 26 | 24 | 83.5 | 65 | 12 | 53 | 5.5 | 24 |
| RMW 300-444-21G0-055 | RP 030S* | 3 | 21 | 0.4 | 63 | 71.7 | 58.7 | 31 | 29 | 86 | 64.5 | 9 | 50 | 6 | 23.5 |
| RMW 300-444-21G0-055 | RP 040S* | 3 | 21 | 0.4 | 63 | 71.7 | 58.7 | 31 | 29 | 97.6 | 76 | 13.5 | 61.5 | 6.1 | 28 |
| RMW 400-444-22G0-073 | RP 040S* | 4 | 22 | 0.2 | 88 | 97.9 | 79.8 | 41 | 39 | 105.1 | 77.5 | 10 | 58 | 7.1 | 29.5 |
| RMW 500-444-21G0-073 | RP 040S* | 5 | 21 | 0.4 | 105 | 119.3 | 88.5 | 51 | 49 | 116 | 83 | 10.5 | 58.5 | 7.5 | 35 |
| RMW 500-444-25G0-106 | RP 050S* | 5 | 25 | 0.2 | 125 | 137.3 | 97.5 | 51 | 49 | 131.1 | 98 | 13.5 | 73.5 | 7.6 | 38 |
| RMW 600-444-20G0-106 | RP 050S* | 6 | 20 | 0.4 | 120 | 137.1 | 105.4 | 61 | 59 | 138.5 | 100 | 10.5 | 70.5 | 8 | 40 |
| RMW 600-444-25G0-128 | RP 060S* | 6 | 25 | 0 | 150 | 162.3 | 118 | 61 | 59 | 153.2 | 113.5 | 14 | 84 | 9.2 | 43.5 |
| RMW 800-444-19G0-128 | RP 060S* | 8 | 19 | 0.4 | 152 | 174.7 | 150.2 | 81 | 79 | 173 | 123.5 | 14 | 84 | 9 | 53.5 |
| RMW 800-444-23G0-156 | RP 080S* | 8 | 23 | 0.2 | 184 | 203.5 | 164.6 | 81 | 79 | 186.6 | 133.4 | 14 | 93.9 | 12.7 | 53.5 |

* also applies to RPM*, RPK*, RPC*

m = Module
z = Number of teeth
d = Pitch circle diameter
x = Profile correction factor
d_a = Tip diameter

Refer to the respective gearbox catalog for the exact gearbox dimensions.

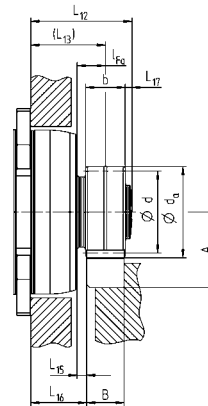

| Pinion designation | Gearbox size | <i>m</i> [mm] | <i>z</i> [] | <i>x</i> [] | <i>d</i> [mm] | <i>d_a</i> [mm] | <i>A</i> ± 0,3 [mm] | <i>b</i> [mm] | <i>B</i> [mm] | <i>L₁₂</i> [mm] | <i>L₁₃</i> [mm] | <i>L₁₅</i> [mm] | <i>L₁₆</i> [mm] | <i>L₁₇</i> [mm] | <i>I_{Fq}</i> [mm] |
|----------------------|--------------|------------------|-----------------|-----------------|------------------|------------------------------|------------------------|------------------|------------------|-------------------------------|-------------------------------|-------------------------------|-------------------------------|-------------------------------|-------------------------------|
| RMW 200-444-22G0-033 | XP 020R* | 2 | 22 | 0.3 | 44 | 49.5 | 44.6 | 26 | 24 | 59.3 | 40.8 | 9 | 28.8 | 5.5 | 20 |
| RMW 200-444-22G0-037 | XP 030R* | 2 | 22 | 0.3 | 44 | 49.5 | 44.6 | 26 | 24 | 69.5 | 51 | 12 | 39 | 5.5 | 21 |
| RMW 300-444-21G0-037 | XP 030R* | 3 | 21 | 0.4 | 63 | 71.7 | 58.7 | 31 | 29 | 76.5 | 54 | 9 | 39.5 | 7 | 24 |
| RMW 300-444-21G0-055 | XP 040R* | 3 | 21 | 0.4 | 63 | 71.7 | 58.7 | 31 | 29 | 75.5 | 54 | 9.5 | 39.5 | 6 | 24 |
| RMW 400-444-22G0-055 | XP 040R* | 4 | 22 | 0.2 | 88 | 97.9 | 79.8 | 41 | 39 | 86.5 | 59 | 9.5 | 39.5 | 7 | 29 |

* also applies to XPK*, XPC*

m = Module
z = Number of teeth
d = Pitch circle diameter
x = Profile correction factor
d_a = Tip diameter

Refer to the respective gearbox catalog for the exact gearbox dimensions.

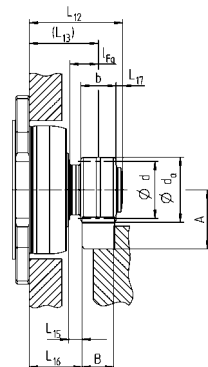

Perfect lubrication – for a perfect system

In order to achieve a long service life, rack and pinion systems require adequate lubrication. We offer different models of lubricators, lubrication pinions and mounting axes, all adapted perfectly to our linear systems. The polyurethane foam lubricating

pinion is supplied via a lubricator with a preset grease quantity determined by you. This ensures an optimal lubricating film on the rack and pinion. In addition to the supply of lubricant, the lubricating pinion also ensures cleaning of the open toothing.

Lubricators LUC+125 and LUC+400

Solutions for decentralized lubrication – a solution you can count on.

Replaceable lubricant container

Time control
Action panel for setting the operating time

Impulse control
Control and voltage supply via machine control system

Up to 4 outlets with up to 2 different freely controllable lubricant quantities

Lubricating pinion
Perfectly adapted to our rack and pinion systems

High-pressure plastic hose
Pre-filled, suitable for cable tracks

Battery-operated version with empty signal and synchronization option

Your benefits

- Ready-to-install solutions – all the required parts are included in the scope of delivery
- Solutions adapted to your application
- With impulse control and 24 V power supply to be fully integrated in the machine control system: lubricant quantities can be precisely adjusted to the application (minimal-quantity lubrication)
- Battery-operated with time control as a standalone solution (LUC+125 only)
- Performance lubricants for different applications
- Significant reduction in maintenance costs
- Exceptionally reliable electromechanical design ensures an extremely long service life for the entire drive system
- Use of cartridges
- One lubricator can supply up to 4 (LUC+125) or 16 (LUC+400) lubrication points by the use of splitters
- Linear guides can also be lubricated in combination with the WITTENSTEIN alpha G13 grease

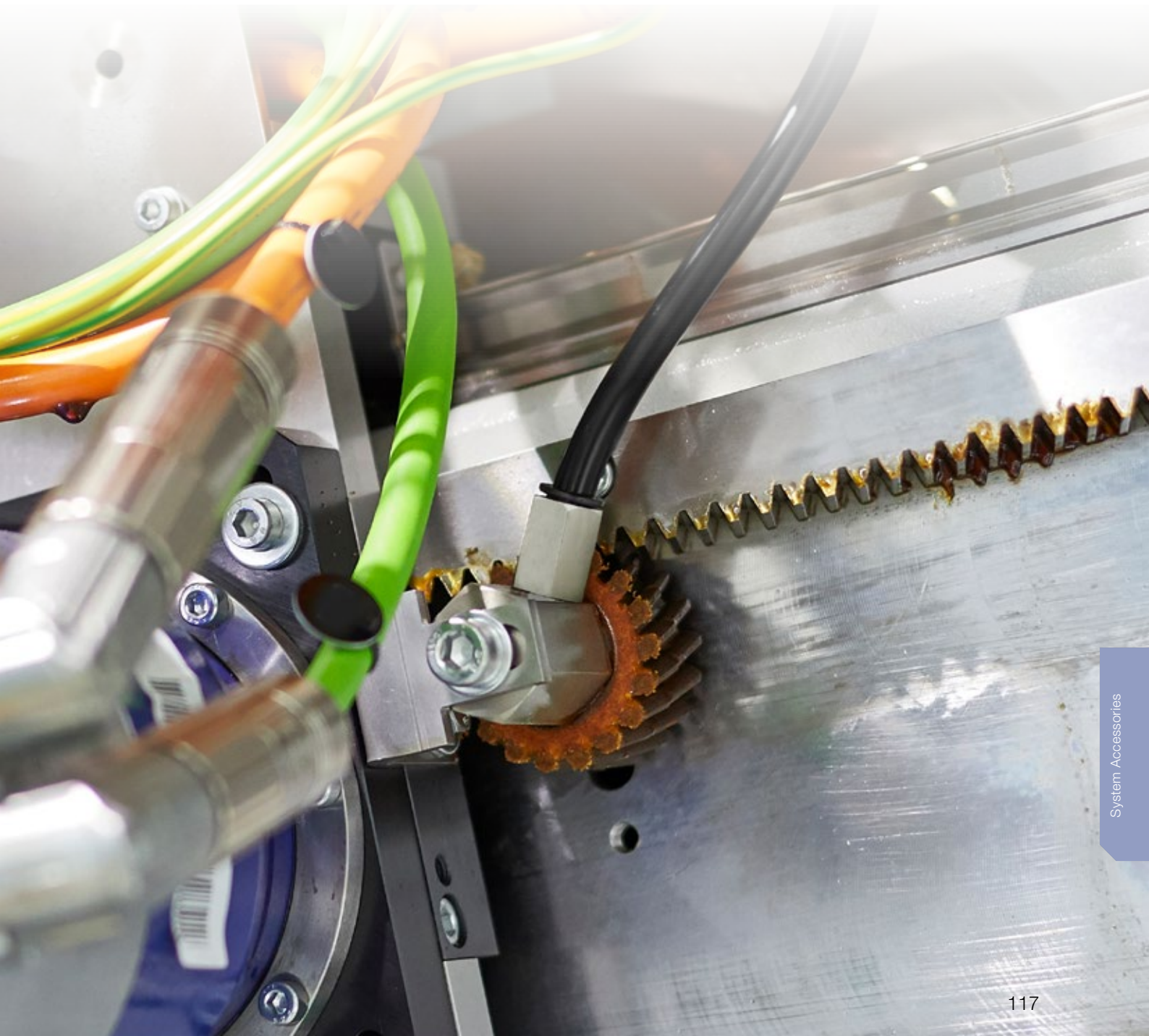

Lubricating pinion

Due to the high feed forces which can occur in a rack and pinion drive, the open toothing must be lubricated at all times. Therefore we recommend automatic re-lubrication using our polyurethane lubricating pinions and lubricators. Re-lubrication with the PU lubricating pinion ensures that the lubricant is applied to the toothing continuously and automatically, while the lubricator supplies lubricant whenever it is needed. For this purpose, the lubricating pinion, which is adapted to the toothing of the pinion or rack, engages with the teeth to ensure that the lubricant is transferred to the toothing

without load. The open-cell polyurethane foam ensures that the perfect quantity of lubricant is supplied to the toothing, even over extremely lengthy periods. The material stores a quantity of lubricant and dispenses it continuously in minute amounts to prevent wear caused by a lack of lubrication. In order to ensure immediate full functionality of the lubricating pinion and to prevent damage to the drive through dry starting, it must be pre-lubricated!

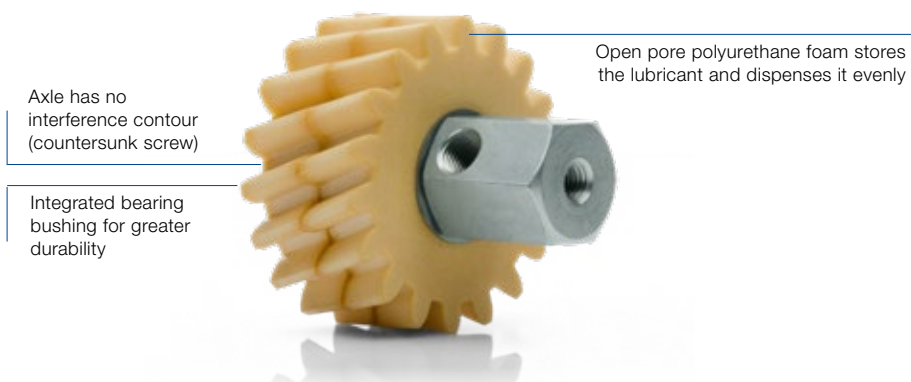

You have the choice – the following lubricants are available for selection:

**WITTENSTEIN alpha G11 –
Standard grease for open gearing**

High-performance grease / adhesive grease for open gearing under extreme loads

- NLGI class 0 – 1
- Long-fibred lithium/calcium complex grease with high pressure additives
- Heat-resistant, good corrosion protection properties
- Does not contain solid lubricants

Applications:

- Used together with a lubrication pinion and continuous re-lubrication for open gearing under extreme loads
- Suitable for a wide range of applications due to high-temperature properties

Available packages: Replacement cartridges LUC+125 / LUC+400; grease gun cartridge; 18 kg tub

Adapted to

Open gearing

**WITTENSTEIN alpha G13 –
Special grease for rack and pinion drives, linear guides
and ball screws**

- Extremely short-fibred and homogeneous, lithium-saponified universal grease containing a mineral oil used to lubricate roller and slide bearings and is suitable for medium to high loads
- Extremely adhesive; suitable for short stroke applications
- Water-resistant and protects against corrosion

Applications:

- Used together with a lubrication pinion and continuous re-lubrication for open gearing
- Lubrication of linear guides and ball screws

Available packages: Replacement cartridges LUC+125 / LUC+400; grease gun cartridge; 18 kg tub

Adapted to

Open gearing Linear guide Ball screw



Determining lubrication quantities

The lubrication quantity can be estimated depending on the module and feed speed (valid for axes up to 5 m in length). If you wish to obtain a calculation adapted to your application, contact us on Tel. +49 7931 493-0 (Germany), Tel. +1 630 540-5300 (North America), Tel. +44 1782 286 427 (UK)

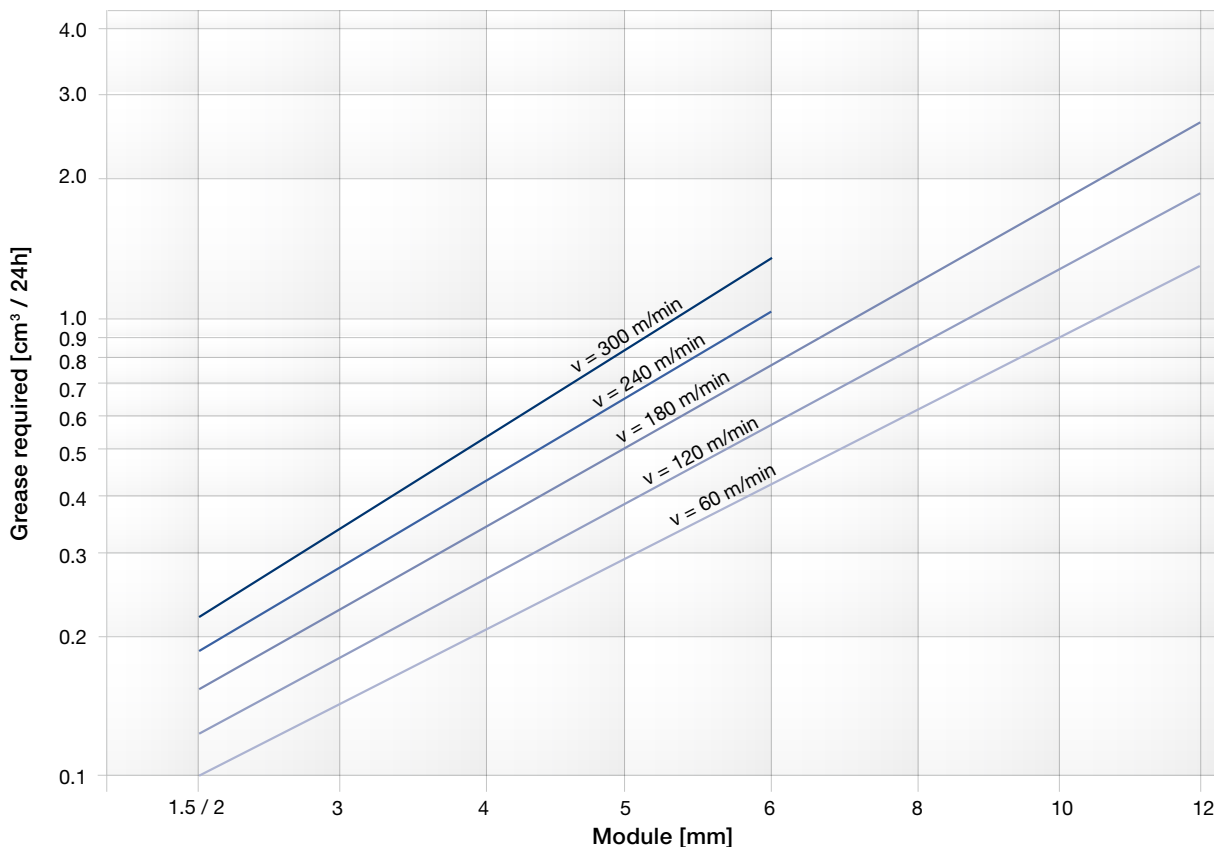

Chart to determine lubricant quantities depending on the module and feed speed

Lubricator LUC+125

Technical data

| | | |
|--|-----------------|---|
| Weight ¹⁾ | | 660 g |
| Lubricant volume | | 125 cm ³ |
| Lubricant type | | Grease up to NLGI 2 |
| Principle of operation | | Piston pump |
| Maximum pressure | Battery version | 12 / 35 bar |
| | 24 V | 12 / 50 bar |
| Metering volume / stroke | | 0.15 cm ³ 4) |
| No. of outlets | | 1 |
| Outlet | | G 1/4" (a) and M6 (i) |
| Max. number of lubrication points with splitters ²⁾ | | 4 |
| Operating voltage | Battery version | 4.5 V DC |
| | 24 V | 24 V DC |
| Current input | Battery version | - |
| | 24 V | 300 mA |
| Fuse | Battery version | - |
| | 24 V | 1 A slow-blow |
| Protection class | | IP 54 |
| Operating temperature ³⁾ | | -20° C to +70° C |
| Control system | Battery version | Microelectronic, external switching element |
| | 24 V | Microelectronic |
| Pressure monitoring | | Integrated, electronic |
| Fill level monitoring | | Integrated, electronic |
| Communication interface | | M12x1, 4-pole |
| Activation of progressive distributor | | Suitable |
| Mounting position | | Preferably vertical |

1) Depending on the version

2) If progressive distributors are used, more lubrication points are possible

3) Depending on the lubricant used

4) Battery version: time-controlled; operating time 1 - 24 months; number of strokes per lubricating cycle can be adjusted
24V: time-controlled: same as battery version; impulse-controlled: lubricating strokes controlled by 2 s pulse signal

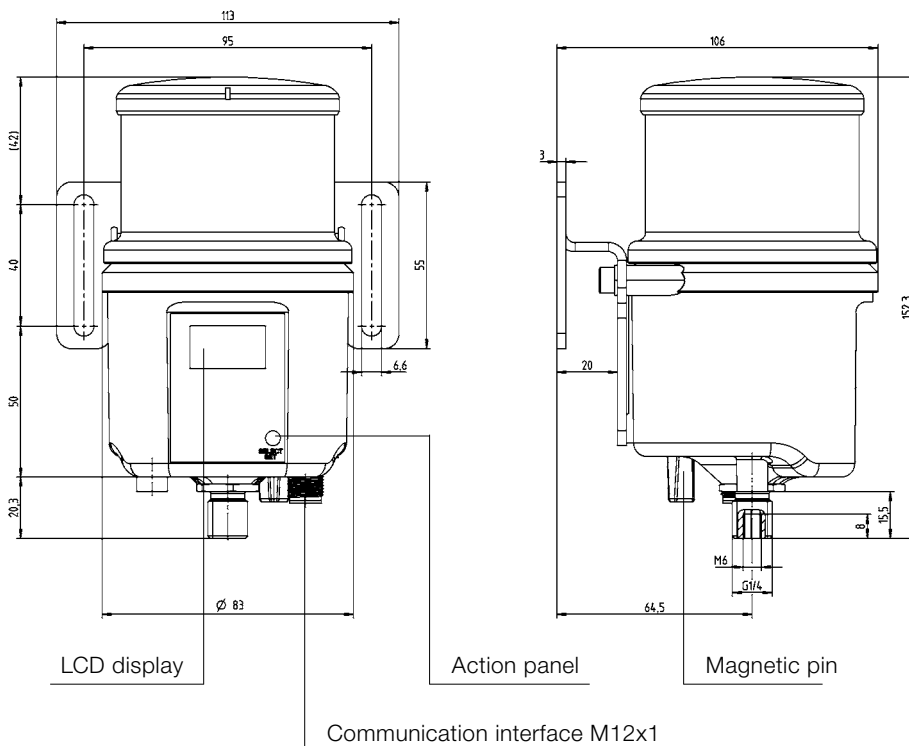

Order information LUC+125

Lubricator versions LUC+125

24 V, impulse-controlled

| Overview of lubrication sets | Outlets | Pump body | Lubricant | Scope of delivery Hoses | Material number |
|------------------------------|---------|-----------|-----------------------|-------------------------|-----------------|
| LUC+125-0511-02 | 1 | 1 | WITTENSTEIN alpha G11 | 2 m | 20068221 |

Lengths up to 8 m max. per outlet possible via hose connector 6-0 and LUH hose.

24 V, time-controlled

| Overview of lubrication sets | Outlets | Pump body | Lubricant | Scope of delivery Hoses | Material number |
|------------------------------|---------|-----------|-----------------------|-------------------------|-----------------|
| LUC+125-0512-02 | 1 | 1 | WITTENSTEIN alpha G11 | 2 m | 20068222 |

Lengths up to 8 m max. per outlet possible via hose connector 6-0 and LUH hose.

Battery version, time-controlled*

| Overview of lubrication sets | Outlets | Pump body | Lubricant | Hoses included | Material number |
|------------------------------|---------|-----------|----------------------|----------------|-----------------|
| LUC+125-0013-02 | 1 | 1 | Klüber Microlube GB0 | 2 m | 20068211 |

*Substitute for LUC 125-C10, 20021555.

Replacement cartridges for LUC+125

| Designation | Lubricant | Filling quantity | Material number |
|---|-----------------------|---------------------|-----------------|
| Replacement cartridge LUE+125-05-1 (for 24 V version) | WITTENSTEIN alpha G11 | 125 cm ³ | 20068231 |
| Replacement cartridge LUE+125-05-2 (incl. alkaline battery) | WITTENSTEIN alpha G11 | 125 cm ³ | 20068241 |

Lubricator LUC+400

Technical data

| | |
|--|--|
| Weight ¹⁾ | 1800 g |
| Lubricant volume | 400 cm ³ |
| Lubricant type | Grease up to NLGI 3 |
| Principle of operation | Piston pump |
| Operating pressure | Max. 70 bar |
| Metering volume / stroke | 0.15 cm ³ (output / pulse signal) |
| No. of outlets | 1, 2, 3, 4 |
| Outlet | Rotating, right-angled hose connections 6 mm up to 150 bar |
| Max. number of lubrication points with splitters ²⁾ | 16 |
| Operating voltage | 24 VDC |
| Current input | I_{max} during operation 350 mA (regular < 200 mA) |
| Fuse | 350 mA (characteristic: medium slow-blow or slow-blow) |
| Protection class | IP 65 |
| Operating temperature ³⁾ | -20° C to +70° C |
| Control system | Integrated, microelectronic |
| Pressure monitoring | Integrated, electronic (system pressure measurement) |
| Fill level monitoring | Integrated, reed contact |
| Communication interface | Connector, M12x1, 4-pole |
| Activation of progressive distributor | Suitable |
| Mounting position | Any |

1) Depending on the version

2) If progressive distributors are used, more lubrication points are possible

3) Depending on the lubricant used

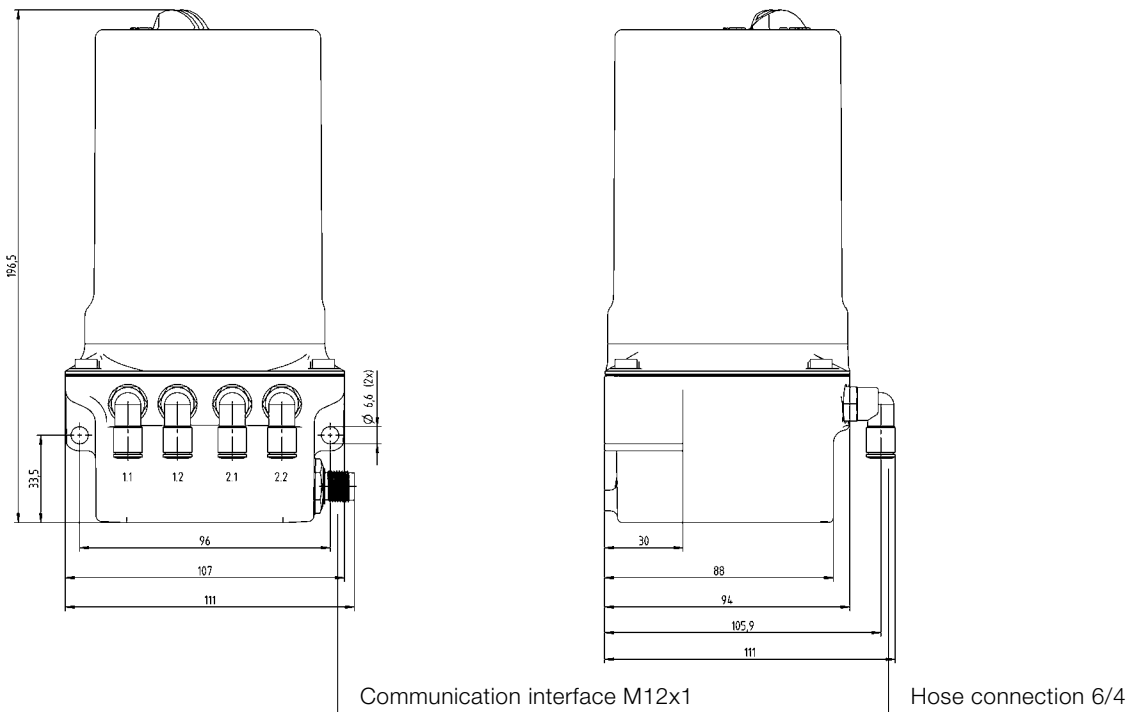

Communication interface M12x1

Hose connection 6/4

Order information LUC+400

Lubricator LUC+400 – filled with WITTENSTEIN alpha G11

With 2 m hose

| Overview of lubrication sets | Outlets | Pump body | Lubricant | Hoses included | Material number |
|------------------------------|---------|-----------|-----------------------|----------------|-----------------|
| LUC+400-0511-02 | 1 | 1 | WITTENSTEIN alpha G11 | 2 m | 20058416 |
| LUC+400-0521-02 | 2 | 1 | WITTENSTEIN alpha G11 | 2 x 2 m | 20058418 |
| LUC+400-0531-02 | 3 | 2 | WITTENSTEIN alpha G11 | 3 x 2 m | 20058420 |
| LUC+400-0541-02 | 4 | 2 | WITTENSTEIN alpha G11 | 4 x 2 m | 20058422 |
| LUC+400-0551-02 | 2 | 2 | WITTENSTEIN alpha G11 | 2 x 2 m | 20058424 |

Lengths up to 10 m max. per outlet possible via hose connector 6-0 and LUH hose.

With 5 m hose

| Overview of lubrication sets | Outlets | Pump body | Lubricant | Hoses included | Material number |
|------------------------------|---------|-----------|-----------------------|----------------|-----------------|
| LUC+400-0511-05 | 1 | 1 | WITTENSTEIN alpha G11 | 5 m | 20058417 |
| LUC+400-0521-05 | 2 | 1 | WITTENSTEIN alpha G11 | 2 x 5 m | 20058419 |
| LUC+400-0531-05 | 3 | 2 | WITTENSTEIN alpha G11 | 3 x 5 m | 20058421 |
| LUC+400-0541-05 | 4 | 2 | WITTENSTEIN alpha G11 | 4 x 5 m | 20058423 |
| LUC+400-0551-05 | 2 | 2 | WITTENSTEIN alpha G11 | 2 x 5 m | 20058425 |

Lengths up to 10 m max. per outlet possible via hose connector 6-0 and LUH hose.

Lubricator LUC+400 – filled with WITTENSTEIN alpha G13

With 2 m hose

| Overview of lubrication sets | Outlets | Pump body | Lubricant | Hoses included | Material number |
|------------------------------|---------|-----------|-----------------------|----------------|-----------------|
| LUC+400-0711-02 | 1 | 1 | WITTENSTEIN alpha G13 | 2 m | 20059848 |
| LUC+400-0721-02 | 2 | 1 | WITTENSTEIN alpha G13 | 2 x 2 m | 20059849 |
| LUC+400-0731-02 | 3 | 2 | WITTENSTEIN alpha G13 | 3 x 2 m | 20059851 |
| LUC+400-0741-02 | 4 | 2 | WITTENSTEIN alpha G13 | 4 x 2 m | 20059853 |
| LUC+400-0751-02 | 2 | 2 | WITTENSTEIN alpha G13 | 2 x 2 m | 20059856 |

Lengths up to 10 m max. per outlet possible via hose connector 6-0 and LUH hose.

With 5 m hose

| Overview of lubrication sets | Outlets | Pump body | Lubricant | Hoses included | Material number |
|------------------------------|---------|-----------|-----------------------|----------------|-----------------|
| LUC+400-0711-05 | 1 | 1 | WITTENSTEIN alpha G13 | 5 m | 20059813 |
| LUC+400-0721-05 | 2 | 1 | WITTENSTEIN alpha G13 | 2 x 5 m | 20059850 |
| LUC+400-0731-05 | 3 | 2 | WITTENSTEIN alpha G13 | 3 x 5 m | 20059852 |
| LUC+400-0741-05 | 4 | 2 | WITTENSTEIN alpha G13 | 4 x 5 m | 20059854 |
| LUC+400-0751-05 | 2 | 2 | WITTENSTEIN alpha G13 | 2 x 5 m | 20059856 |

Lengths up to 10 m max. per outlet possible via hose connector 6-0 and LUH hose.

Replacement cartridges for LUC+400

| Designation | Lubricant | Filling quantity | Material number |
|------------------------------------|-----------------------|---------------------|-----------------|
| Replacement cartridge LUE+400-05-1 | WITTENSTEIN alpha G11 | 400 cm ³ | 20058120 |
| Replacement cartridge LUE+400-07-1 | WITTENSTEIN alpha G13 | 400 cm ³ | 20058122 |

Accessories for LUC+125 and LUC+400

Pre-filled hoses

| Designation | Lubricant | Type | Hose diameter [mm] | Material number |
|-----------------------------------|-----------------------|----------|--------------------|-----------------|
| Hose 2 m, LUH-02-05 ^{a)} | WITTENSTEIN alpha G11 | 2 m | 6 | 20058134 |
| Hose 5 m, LUH-05-05 ^{a)} | WITTENSTEIN alpha G11 | 5 m | 6 | 20058135 |
| Hose 2 m, LUH-02-07 ^{a)} | WITTENSTEIN alpha G13 | 2 m | 6 | 20058138 |
| Hose 5 m, LUH-05-07 ^{a)} | WITTENSTEIN alpha G13 | 5 m | 6 | 20058139 |
| Hose connector 6-0 | - | Straight | 6 | 20058148 |

a) Hoses pre-filled. Only use air-free pre-filled hoses!

Lubricants

| Designation | Lubricant | Filling quantity | Material number |
|----------------------------------|-----------------------|---------------------|-----------------|
| Grease gun cartridge, LGC-400-05 | WITTENSTEIN alpha G11 | 400 cm ³ | 20058111 |
| Grease gun cartridge, LGC-400-07 | WITTENSTEIN alpha G13 | 400 cm ³ | 20058113 |
| Hobbock / tub, LUB 18-05 | WITTENSTEIN alpha G11 | 18 kg | 20065366 |
| Hobbock / tub, LUB 18-07 | WITTENSTEIN alpha G13 | 18 kg | 20065524 |

Hose connectors / communication interface connection

| Designation | Thread/connection | Type | Hose diameter [mm] | Material number |
|-----------------------------|-------------------|----------|--------------------|-----------------|
| Hose connection G1/4-6-0 | G 1/4" | Straight | 6 | 20058144 |
| Hose connection M06-6-1 | M6x1 | Angled | 6 | 20058145 |
| Hose connection M10-6-0 | M10x1 | Straight | 6 | 20070402 |
| Hose connection G1/8-6-1 | G 1/8" | Angled | 6 | 20058146 |
| Hose connection M10x1-6-1 | M10x1 | Angled | 6 | 20061741 |
| Hose connection G1/4-6-1 | G 1/4" | Angled | 6 | 20058147 |
| Angled connector 24V, 4-pin | M12x1 | Angled | - | 20058149 |

Distributor – splitter

| Designation | Hose connection | No. of outlets | Hose diameter [mm] | Material number |
|---------------------|--------------------|----------------|--------------------|-----------------|
| Splitter LUS 2-0-NL | Straight / plug-in | 2 | 6 | 20058103 |
| Splitter LUS 3-0-NL | Straight / plug-in | 3 | 6 | 20058104 |
| Splitter LUS 4-0-NL | Straight / plug-in | 4 | 6 | 20058105 |

Dimensions of lubricating pinion and mounting axis

Set consisting of lubrication pinion and lubrication axis

| Module [mm] | z | Flank direction | Use | d [mm] | d ₂ [mm] | d ₃ ²⁾ [mm] | d _k [mm] | b [mm] | L [mm] | l1 [mm] | l2 [mm] | SW [mm] | Ordering code | Material number |
|-------------|----|-----------------|---------------|--------|---------------------|-----------------------------------|---------------------|--------|--------|---------|---------|---------|-----------------------|-----------------|
| 1.5 | 24 | Left | Rack | 38.2 | M8 | M10x1 | 41.2 | 20 | 51.4 | 30 | 10 | 24 | LMT 150-PU-24L1-020-1 | 20064005 |
| | | Right | Pinion | | | | | | | | | | LMT 150-PU-24R1-020-1 | 20064007 |
| | | Straight | Pinion / Rack | 36 | M8 | M10x1 | 39 | 20 | 51.4 | 30 | 10 | 24 | LMT 150-PU-24G0-020-1 | 20064003 |
| 2 | 18 | Left | Rack | 38.2 | M8 | M10x1 | 42.2 | 24 | 55.4 | 30 | 10 | 24 | LMT 200-PU-18L1-024-1 | 20053903 |
| | | Right | Pinion | | | | | | | | | | LMT 200-PU-18R1-024-1 | 20053904 |
| | 17 | Straight | Pinion / Rack | 34 | M8 | M10x1 | 38 | 20 | 51.4 | 30 | 10 | 24 | LMT 200-PU-17G0-020-1 | 20056502 |
| 3 | 18 | Left | Rack | 57.3 | M8 | M10x1 | 63.3 | 30 | 61.4 | 30 | 10 | 24 | LMT 300-PU-18L1-030-1 | 20053905 |
| | | Right | Pinion | | | | | | | | | | LMT 300-PU-18R1-030-1 | 20053906 |
| | 17 | Straight | Pinion / Rack | 51 | M8 | M10x1 | 57 | 30 | 61.4 | 30 | 10 | 24 | LMT 300-PU-17G0-030-1 | 20056503 |
| 4 | 18 | Left | Rack | 76.4 | M8 | M10x1 | 84.4 | 40 | 71.4 | 30 | 10 | 24 | LMT 400-PU-18L1-040-1 | 20053907 |
| | | Right | Pinion | | | | | | | | | | LMT 400-PU-18R1-040-1 | 20053908 |
| | 17 | Straight | Pinion / Rack | 68 | M8 | M10x1 | 76 | 40 | 71.4 | 30 | 10 | 24 | LMT 400-PU-17G0-040-1 | 20056504 |
| 5 | 17 | Left | Rack | 90.2 | M8 | M10x1 | 100.2 | 50 | 81.4 | 30 | 10 | 24 | LMT 500-PU-17L1-050-1 | 20053909 |
| | | Right | Pinion | | | | | | | | | | LMT 500-PU-17R1-050-1 | 20053910 |
| | | Straight | Pinion / Rack | 85 | M8 | M10x1 | 95 | 50 | 81.4 | 30 | 10 | 24 | LMT 500-PU-17G0-050-1 | 20056505 |
| 6 | 17 | Left | Rack | 108.2 | M8 | M10x1 | 120.2 | 60 | 91.4 | 30 | 10 | 24 | LMT 600-PU-17L1-060-1 | 20053911 |
| | | Right | Pinion | | | | | | | | | | LMT 600-PU-17R1-060-1 | 20053912 |
| | | Straight | Pinion / Rack | 102 | M8 | M10x1 | 114 | 60 | 91.4 | 30 | 10 | 24 | LMT 600-PU-17G0-060-1 | 20056506 |
| 8 | 17 | Left | Rack | 144.3 | M8 | M10x1 | 160.3 | 80 | 111.4 | 30 | 10 | 24 | LMT 800-PU-17L1-080-1 | 20053913 |
| | | Right | Pinion | | | | | | | | | | LMT 800-PU-17R1-080-1 | 20053914 |
| | | Straight | Pinion / Rack | 136 | M8 | M10x1 | 152 | 80 | 111.4 | 30 | 10 | 24 | LMT 800-PU-17G0-080-1 | 20056507 |

Connector for hose Ø 6 x 4 mm included in scope of delivery. Lubricating pinions must be soaked in lubricant before operation.

z = Number of teeth

2) Hose connection G1/8" also compatible

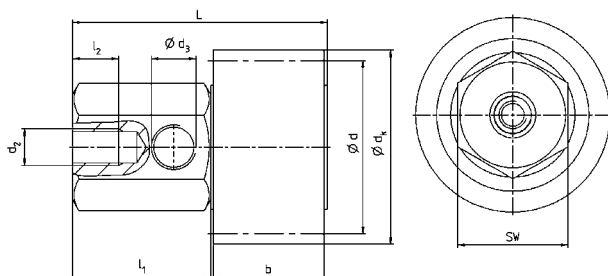

Lubricating pinion

| Module [mm] | Number of teeth | Flank direction | Use | d [mm] | d_1 [mm] | d_k [mm] | b [mm] | Ordering code | Material number |
|-------------|-----------------|-----------------|---------------|----------|------------|------------|----------|---------------------|-----------------|
| 1.5 | 24 | Left | Rack | 38.2 | 12 | 41.2 | 20 | RLU 150-PU-24L1-020 | 20063900 |
| | 24 | Right | Pinion | 38.2 | 12 | 41.2 | 20 | RLU 150-PU-24R1-020 | 20063898 |
| | 24 | Straight | Rack / Pinion | 36 | 12 | 39 | 20 | RLU 150-PU-24G0-020 | 20063902 |
| 2 | 18 | Left | Rack | 38.2 | 12 | 42.2 | 24 | RLU 200-PU-18L1-024 | 20053683 |
| | 18 | Right | Pinion | 38.2 | 12 | 42.2 | 24 | RLU 200-PU-18R1-024 | 20053684 |
| | 17 | Straight | Rack / Pinion | 34 | 12 | 38 | 20 | RLU 200-PU-17G0-020 | 20056509 |
| 3 | 18 | Left | Rack | 57.3 | 12 | 63.3 | 30 | RLU 300-PU-18L1-030 | 20053685 |
| | 18 | Right | Pinion | 57.3 | 12 | 63.3 | 30 | RLU 300-PU-18R1-030 | 20053686 |
| | 17 | Straight | Rack / Pinion | 51 | 12 | 57 | 30 | RLU 300-PU-17G0-030 | 20056510 |
| 4 | 18 | Left | Rack | 76.4 | 12 | 84.4 | 40 | RLU 400-PU-18L1-040 | 20053687 |
| | 18 | Right | Pinion | 76.4 | 12 | 84.4 | 40 | RLU 400-PU-18R1-040 | 20053688 |
| | 17 | Straight | Rack / Pinion | 68 | 12 | 76 | 40 | RLU 400-PU-17G0-040 | 20056511 |
| 5 | 17 | Left | Rack | 90.2 | 20 | 100.2 | 50 | RLU 500-PU-17L1-050 | 20053689 |
| | 17 | Right | Pinion | 90.2 | 20 | 100.2 | 50 | RLU 500-PU-17R1-050 | 20053690 |
| | 17 | Straight | Rack / Pinion | 85 | 20 | 95 | 50 | RLU 500-PU-17G0-050 | 20056512 |
| 6 | 17 | Left | Rack | 108.2 | 20 | 120.2 | 60 | RLU 600-PU-17L1-060 | 20053691 |
| | 17 | Right | Pinion | 108.2 | 20 | 120.2 | 60 | RLU 600-PU-17R1-060 | 20053692 |
| | 17 | Straight | Rack / Pinion | 102 | 20 | 114 | 60 | RLU 600-PU-17G0-060 | 20056513 |
| 8 | 17 | Left | Rack | 144.3 | 20 | 160.3 | 80 | RLU 800-PU-17L1-080 | 20053693 |
| | 17 | Right | Pinion | 144.3 | 20 | 160.3 | 80 | RLU 800-PU-17R1-080 | 20053694 |
| | 17 | Straight | Rack / Pinion | 136 | 20 | 152 | 80 | RLU 800-PU-17G0-080 | 20056514 |

Lubricating pinions must be soaked in lubricant before operation.

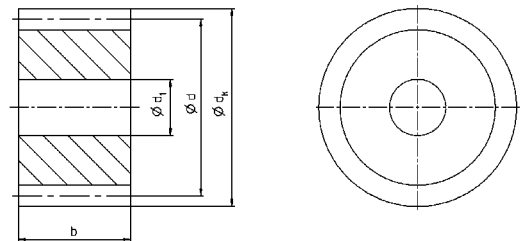

Mounting axis, right-angle

| Module [mm] | d_1 [mm] | d_2 [mm] | Connection thread $d_3^{2)}$ [mm] | b [mm] | L [mm] | l_1 [mm] | l_2 [mm] | SW [mm] | Ordering code | Material number |
|-----------------|------------|------------|-----------------------------------|----------|----------|------------|------------|---------|---------------|-----------------|
| 1.5 | 12 | M8 | M10x1 | 20 | 51.4 | 30 | 10 | 24 | LAS-020-012-1 | 20056520 |
| 2 | 12 | M8 | M10x1 | 24 | 55.4 | 30 | 10 | 24 | LAS-024-012-1 | 20053696 |
| 2 ¹⁾ | 12 | M8 | M10x1 | 20 | 51.4 | 30 | 10 | 24 | LAS-020-012-1 | 20056520 |
| 3 | 12 | M8 | M10x1 | 30 | 61.4 | 30 | 10 | 24 | LAS-030-012-1 | 20053698 |
| 4 | 12 | M8 | M10x1 | 40 | 71.4 | 30 | 10 | 24 | LAS-040-012-1 | 20053700 |
| 5 | 20 | M8 | M10x1 | 50 | 81.4 | 30 | 10 | 24 | LAS-050-020-1 | 20053702 |
| 6 | 20 | M8 | M10x1 | 60 | 91.4 | 30 | 10 | 24 | LAS-060-020-1 | 20053704 |
| 8 | 20 | M8 | M10x1 | 80 | 111.4 | 30 | 10 | 24 | LAS-080-020-1 | 20053706 |

Straight connection for hose $\varnothing 6 \times 4$ mm included in scope of delivery

1) Only compatible with straight-toothed lubricating pinions

2) Hose connection G1/8" also compatible

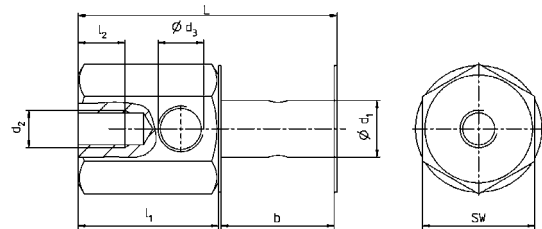

Mounting axis, straight

| Module [mm] | d_1 [mm] | d_2 [mm] | Connection thread $d_3^{2)}$ [mm] | b [mm] | L [mm] | l_1 [mm] | l_2 [mm] | SW [mm] | Ordering code | Material number |
|-----------------|------------|------------|-----------------------------------|----------|----------|------------|------------|---------|---------------|-----------------|
| 1.5 | 12 | M10 | M6 | 20 | 61.2 | 30 | 10 | 15 | LAS-020-012-0 | 20056539 |
| 2 | 12 | M10 | M6 | 24 | 61 | 30 | 10 | 15 | LAS-024-012-0 | 20053695 |
| 2 ¹⁾ | 12 | M10 | M6 | 20 | 61.2 | 30 | 10 | 15 | LAS-020-012-0 | 20056539 |
| 3 | 12 | M10 | M6 | 30 | 71 | 30 | 10 | 15 | LAS-030-012-0 | 20053697 |
| 4 | 12 | M10 | M6 | 40 | 81 | 30 | 10 | 15 | LAS-040-012-0 | 20053699 |
| 5 | 20 | M16 | M10x1 ²⁾ | 50 | 116.4 | 49 | 10 | 24 | LAS-050-020-0 | 20053701 |
| 6 | 20 | M16 | M10x1 ²⁾ | 60 | 126.4 | 49 | 10 | 24 | LAS-060-020-0 | 20053703 |
| 8 | 20 | M16 | M10x1 ²⁾ | 80 | 146.4 | 49 | 10 | 24 | LAS-080-020-0 | 20053705 |

Straight connection for hose $\varnothing 6 \times 4$ mm included in scope of delivery

1) Only compatible with straight-toothed lubricating pinions

2) Hose connection G1/8" also compatible

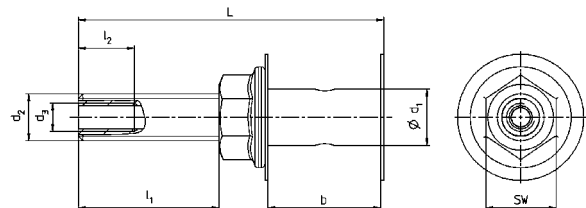



Accessories – Rack installation

The assembly quality decides

The quality of the rack installation has a decisive influence on the properties of the linear systems regarding smooth running, positioning accuracy and load-bearing capacity. We provide all the right assembly accessories needed to achieve maximum potential. In addition to accessories for the standard rack installation, the following section also presents INIRA® assembly accessories for maximum assembly efficiency.

Read our manual available from the download area of our website or watch our assembly film at <https://alpha.wittenstein.de/rack-assembly/> for more information on rack installation and design according to assembly requirements.



alpha.wittenstein.de/rack-assembly



We have a global presence and are happy to offer you on-site assembly training

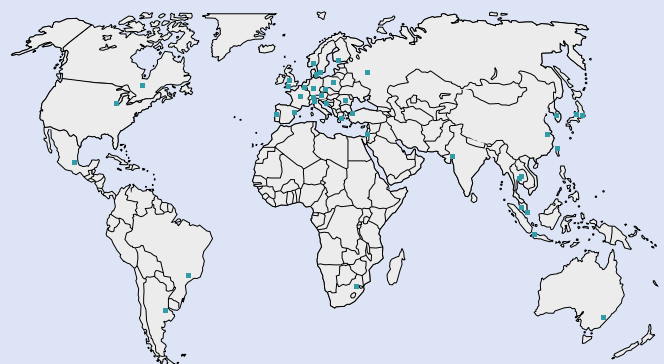

24 h service hotline: +49 7931 493-12900

Accessories – Standard rack installation

Assembly jig

You will need an assembly jig to align the transfers between the individual racks.



| Module [mm] | L [mm] | Ordering code | Material number |
|-------------|--------|-----------------|-----------------|
| 1.5 | 100 | ZMT 150-PD5-100 | 20064154 |
| 2 | 100 | ZMT 200-PD5-100 | 20020582 |
| 3 | 100 | ZMT 300-PD5-100 | 20021966 |
| 4 | 156 | ZMT 400-PD5-156 | 20037466 |
| 5 | 156 | ZMT 500-PD5-156 | 20037469 |
| 6 | 156 | ZMT 600-PD5-156 | 20037470 |
| 8 | 240 | ZMT 800-PB6-240 | 20052289 |

Needle roller

High-precision needle rollers are required when checking during and after assembly using the dial gauge.

| Module [mm] | Material number |
|-------------|-----------------|
| 1.5 | 20006839 |
| 2 | 20001001 |
| 3 | 20000049 |
| 4 | 20038001 |
| 5 | 20038002 |
| 6 | 20038003 |
| 8 | 20052298 |

Accessories – INIRA® rack assembly

INIRA® clamping: determining the required screw length

The screw-in depth of the fastening screws used on racks is based on the shear strength τ_b of the inner thread material. Screws with property class 12.9 must be used to fasten racks. The required shear strength can be calculated with reference to VDI 2230.

The correct screws are included in the scope of delivery of the rack with INIRA® clamping. Please select the most suitable screw length for your application using the table below and complete the rack ordering code accordingly.

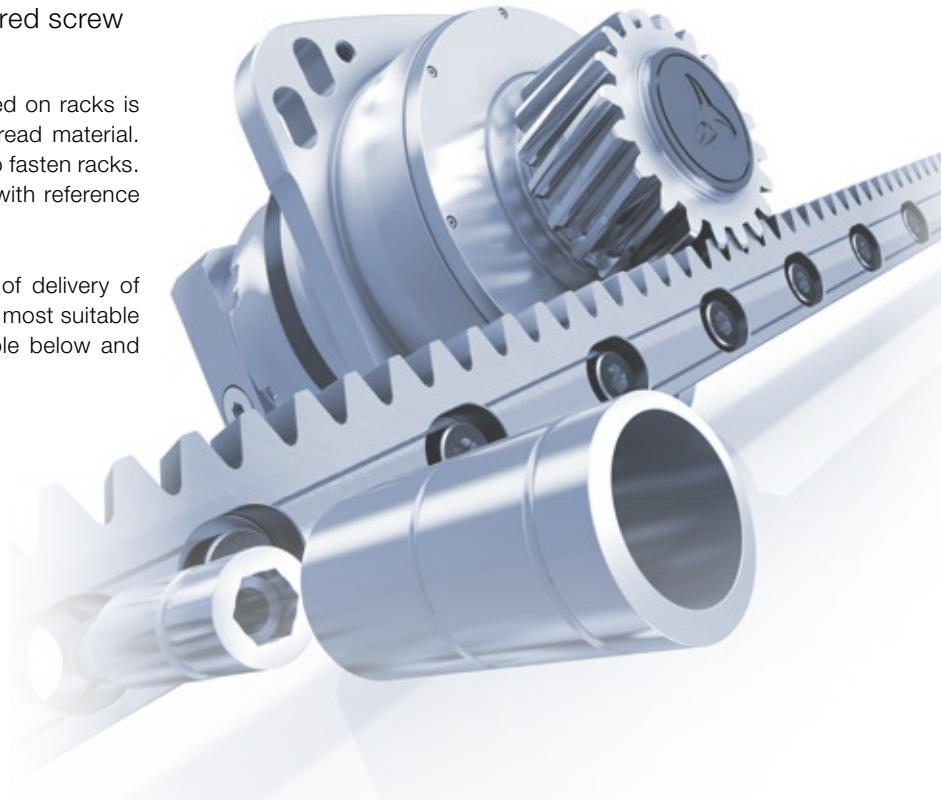

| | | $T_b > 300 \text{ N/mm}^2$ | | $T_b > 200 \text{ N/mm}^2$ | | |
|--------------------------|---|----------------------------|-----------------------|----------------------------|---------------------------|---|
| | | S355 | 306 N/mm ² | S235 | 216 N/mm ² | Mounting base material |
| | | 35S20 | 324 N/mm ² | EN-GJL-250 | 275 N/mm ² | |
| | | C45+N | 372 N/mm ² | EN-GJL-300 | 270 N/mm ² | |
| | | C45+QT | 420 N/mm ² | EN-AW-AISiMgMn | 201–300 N/mm ² | |
| | | 42CrMoV4+QT | 600 N/mm ² | | | |
| | | EN-GJS-400 | 360 N/mm ² | | | |
| Rack, module [mm] | 2 | M6x30 | | M6x35 | | INIRA® screws, thread x length* [mm] |
| | 3 | M8x35 | | M8x45 | | |
| | 4 | M10x45 | | M10x50 | | |
| | 5 | M12x60 | | M12x65 | | |
| | 6 | M16x70 | | M16x80 | | |

* Further screw lengths available on request.

Rack

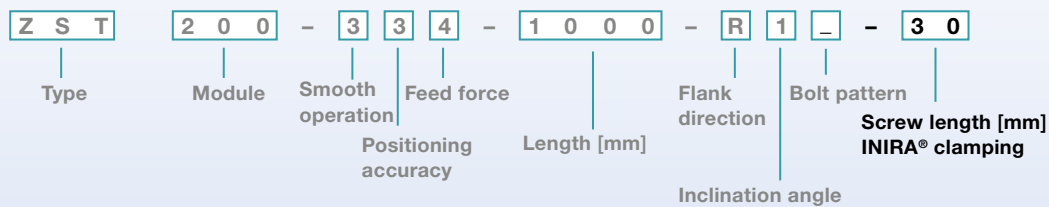

INIRA® tool kit

The INIRA® tool kit contains a host of useful tools for mounting racks efficiently. You can choose the most suitable set based on the rack variant selected.

All essential special tools are included:

- 1 x assembly jig for approximate adjustment of the rack transition
- 1 x adjusting tool for precise adjustment of the rack transition
- 16 x clamping sleeves for clamping the rack to the mounting surface quickly and efficiently
- 8 x needle or cylinder rollers for monitoring the roller dimension during assembly

| Module [mm] | Use | Ordering code | Material number |
|-------------|-----------------------|---------------|-----------------|
| 2 | Hole distance 62.5 mm | ZMTK 200 C | 20066211 |
| | Hole distance 125 mm | ZMTK 200 D | 20066212 |
| 3 | Hole distance 62.5 mm | ZMTK 300 C | 20066213 |
| | Hole distance 125 mm | ZMTK 300 D | 20066214 |
| 4 | Hole distance 62.5 mm | ZMTK 400 C | 20066215 |
| | Hole distance 125 mm | ZMTK 400 D | 20066216 |
| 5 | Hole distance 62.5 mm | ZMTK 500 C | 20066217 |
| | Hole distance 125 mm | ZMTK 500 D | 20066218 |
| 6 | Hole distance 62.5 mm | ZMTK 600 C | 20066219 |
| | Hole distance 125 mm | ZMTK 600 D | 20066220 |



Adjustment tool INIRA® adjusting

Even if you have only selected the INIRA® pinning variants, you can still use the adjustment tool. You can choose the most suitable adjustment tool based on the selected rack variant.

| Module [mm] | Use | Ordering code | Material number |
|-------------|-----------------------|---------------|-----------------|
| 2 | Hole distance 62.5 mm | IZMT 200 C | 20066196 |
| | Hole distance 125 mm | IZMT 200 D | 20066198 |
| 3 | Hole distance 62.5 mm | IZMT 300 C | 20066199 |
| | Hole distance 125 mm | IZMT 300 D | 20066200 |
| 4 | Hole distance 62.5 mm | IZMT 400 C | 20067988 |
| | Hole distance 125 mm | IZMT 400 D | 20066202 |
| 5 | Hole distance 62.5 mm | IZMT 500 C | 20067992 |
| | Hole distance 125 mm | IZMT 500 D | 20066204 |
| 6 | Hole distance 62.5 mm | IZMT 600 C | 20066205 |
| | Hole distance 125 mm | IZMT 600 D | 20066206 |

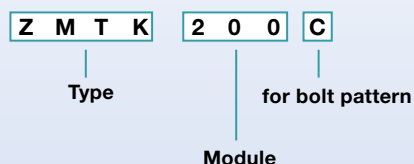

Glossary – the **alphabet**

cymex®

cymex® is the calculation software developed by our company for dimensioning complete drive trains. The software enables the precise simulation of motion and load variables. The software is available for download from our website (www.wittenstein-cymex.com). We can also provide training to enable you to make full use of all the possibilities provided by the software.

Efficiency (η)

Efficiency [%] η is the ratio of output power to input power. Power lost through friction reduces efficiency to less than 1 or 100 %.

$$\eta = P_{\text{off}} / P_{\text{on}} = (P_{\text{on}} - P_{\text{loss}}) / P_{\text{on}}$$

Sample curve of the efficiency factor of a planetary gear depending on the torque

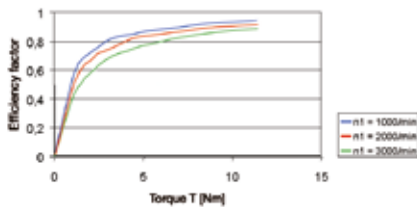

WITTENSTEIN alpha always measures the efficiency of a gearbox during operation at full load. If the input power or torque are lower, the efficiency rating is also lower due to the constant no-load torque. Power losses do not increase as a result. A lower efficiency is also expected at high speeds (see illustration).

HIGH TORQUE (MA)

WITTENSTEIN alpha gearboxes are also available in a HIGH TORQUE version. These gearboxes are particularly suited to applications requiring extremely high torques and maximum rigidity.

Jerk (j)

Jerk is derived from acceleration and is defined as the change in acceleration within a unit of time. The term impact is used if the acceleration curve changes abruptly and the jerk is infinitely large.

Load factor (f_s)

The maximum permissible acceleration torque during cyclic operation specified in the catalog counts for a cycle rate of

less than 1000/h. Higher cycle rates combined with short acceleration times can cause vibrations in the drive train. Use the load factor f_s to consider the resulting excess torque values in calculations. The impact factor f_s can be determined with reference to the curve.

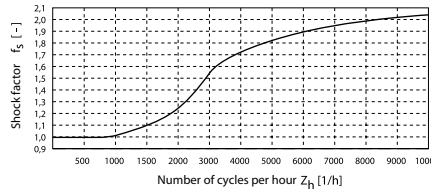

This calculated value is multiplied by the actual acceleration torque T_{2b} and then compared with the maximum permissible acceleration torque T_{2B} .

$$(T_{2b} \cdot f_s = T_{2b, fs} < T_{2B})$$

Mass moment of inertia (J)

The mass moment of inertia J [kg/cm²] is a measurement of the effort applied by an object to maintain its momentary condition (at rest or moving).

Mass inertia ratio ($\lambda = \text{Lambda}$)

The mass inertia ratio λ is the ratio of external inertia (application side) to internal inertia (motor and gearbox side). It is an important parameter determining the controllability of an application. Accurate control of dynamic processes becomes more difficult with differing mass moments of inertia and as λ becomes greater. WITTENSTEIN alpha recommends that a guideline value of $\lambda < 5$ is maintained. A gearbox reduces the external mass moment of inertia by a factor of $1/i^2$.

$$\lambda = \frac{J_{\text{external}}}{J_{\text{internal}}}$$

J reduced externally at input:

$$J'_{\text{external}} = J_{\text{external}} / i^2$$

Simple applications ≤ 10

Dynamic applications ≤ 5

Highly dynamic applications ≤ 1

Safety note

For applications with special safety requirements (e.g. vertical axes, clamped drives), we recommend exclusive use of our Premium and Advanced products (excluding V-Drive).

Servo actuators

In addition to a high-precision planetary gearbox, the servo actuator is fitted with a powerful, permanently actuated synchronous servo motor that guarantees a high power density and a constant speed due to a distributed winding. Therefore even more compact and powerful linear drives can be realized. Investment effort for the drive train and the operating cost can be influenced positively with so called downsizing. The goal is to use a smaller drive train thus a smaller servo-controller with lower energy consumption while achieving the same productivity. Therefore a lower mass moment of inertia and simultaneously a higher rigidity are the path to success.

Speed (n)

Two speeds are of relevance when dimensioning a gearbox: the maximum speed and the thermal speed limit at the input. The maximum permissible speed n_{1Max} must not be exceeded because it serves as the basis for dimensioning **→ cyclic operation**. The nominal speed n_{1N} must not be exceeded in **→ continuous operation**. The housing temperature, which must not exceed 90 °C, limits the thermal speed limit n_{1T} . At an ambient temperature of 20 °C, it is determined by the maximum gearbox temperature of $T = 90$ °C under no-load conditions. As can be seen in the diagram below, the temperature limit is reached more quickly in the presence of an elevated outside temperature. In other words: the nominal input speed must be reduced if the ambient temperature is high. The values applicable to your gearbox are available from WITTENSTEIN alpha on request.

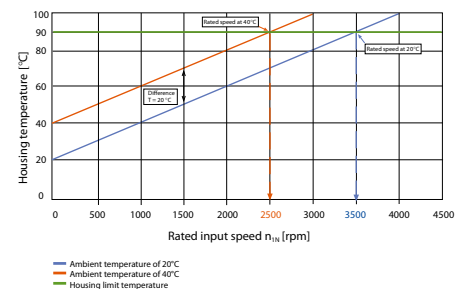

Synchronization

Synchronization refers to the variation in speed measured between the input and output during one revolution of the output shaft. It is caused by manufacturing tolerances and results in minute angular deviations and fluctuations in ratio.

Tilting torque (M_{2K})

The tilting torque M_{2K} is a result of the → **axial and lateral forces** applied and their respective points of application in relation to the inner radial bearing on the output side.

Torsional backlash (j_t)

Torsional backlash j_t [arcmin] is the maximum angle of torsion of the output shaft in relation to the input. Simply put, the torsional backlash represents the gap between two tooth flanks.

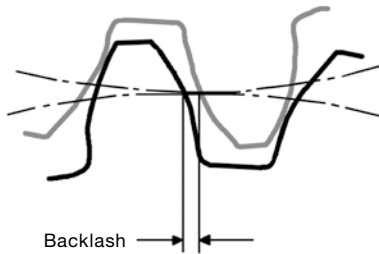

Torsional backlash is measured with the input shaft locked.

The output is then loaded with a defined test torque in order to overcome the internal gearbox friction. The main factor affecting torsional backlash is the face clearance between the gear teeth. The low torsional backlash of WITTENSTEIN alpha gearboxes is due to their high manufacturing accuracy and the specific combination of gear wheels.

→ Refer to this term for further details.

Glossary – Formulae

Formulae

| | | |
|---|--|---|
| Torque [Nm] | $T = J \cdot \alpha$ | J = Mass moment of inertia [kgm ²] α = Angular acceleration [1/s ²] |
| Torque [Nm] | $T = F \cdot l$ | F = Force [N] l = Lever, length [m] |
| Acceleration force [N] | $F_b = m \cdot a$ | m = Mass [kg] a = Linear acceleration [m/s ²] |
| Frictional force [N] | $F_{\text{Reib}} = m \cdot g \cdot \mu$ | g = Acceleration due to gravity 9.81 m/s ² μ = Coefficient of friction |
| Angular speed [1/s] | $\omega = 2 \cdot \pi \cdot n / 60$ | n = Speed [rpm] π = PI = 3.14... |
| Linear speed [m/s] | $v = \omega \cdot r$ | v = Linear speed [m/s] r = Radius [m] |
| Linear speed [m/s] (spindle) | $v_{\text{sp}} = \omega \cdot h / (2 \cdot \pi)$ | h = Screw pitch [m] |
| Linear acceleration [m/s²] | $a = v / t_b$ | t_b = Acceleration time [s] |
| Angular acceleration [1/s²] | $\alpha = \omega / t_b$ | |
| Pinion path [mm] | $s = m_n \cdot z \cdot \pi / \cos \beta$ | m_n = Normal module [mm] z = Number of teeth [-] β = Helix angle [°] |

Conversion table

| | |
|---------------------------|--|
| 1 mm | = 0.039 in |
| 1 Nm | = 8.85 in.lb |
| 1 kgcm² | = 8.85 x 10 ⁻⁴ in.lb.s ² |
| 1 N | = 0.225 lb _f |
| 1 kg | = 2.21 lb _m |

Symbol

| Symbol | Unit | Designation |
|----------|------------------|----------------------------------|
| C | Nm/arcmin | Rigidity |
| ED | %, min | Duty cycle |
| F | N | Force |
| f_s | – | Load factor |
| f_e | – | Factor for duty cycle |
| i | – | Ratio |
| j | arcmin | Backlash |
| J | kgm ² | Mass moment of inertia |
| $K1$ | Nm | Factor for bearing calculation |
| L | h | Service life |
| L_{PA} | dB(A) | Operating noise |
| m | kg | Mass |
| M | Nm | Torque |
| n | rpm | Speed |
| p | – | Exponent for bearing calculation |
| η | % | Efficiency |
| t | s | Time |
| T | Nm | Torque |
| v | m/min | Linear speed |
| z | 1/h | Number of cycles |

Index

| Index | Designation |
|----------------|--------------------|
| Capital letter | Permissible values |
| Small letter | Actual values |
| 1 | Input |
| 2 | Output |
| A/a | Axial |
| B/b | Acceleration |
| c | Constant |
| d | Deceleration |
| e | Pause |
| h | Hours |
| K/k | Tilting |
| m | Mean |
| Max/max | Maximum |
| Mot | Motor |
| N | Nominal |
| Not/not | Emergency stop |
| 0 | No load |
| Q/q | Lateral |
| t | Torsional |
| T | Tangential |

Compendium

Drive design

Various types of rack and pinion systems are used depending on the application. In addition to a single drive for simple movements and positioning tasks, backlash-free, electrically preloaded drives (master/slave) are often used for precision applications, and rack and pinion systems in a gantry arrangement are used for large machines with guides positioned far apart (e.g. wide tables or portals).

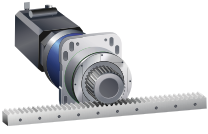
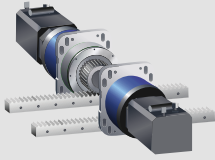
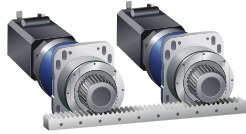
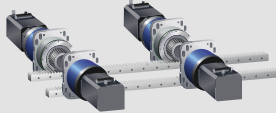
| | Single drive | Gantry | Master/slave (electrically preloaded) | Gantry master/slave (electrically preloaded) |
|--------------|---|---|--|---|
| Design |  |  |  |  |
| Backlash | Present | Present | Backlash free | Backlash free |
| Applications | Secondary requirements for positioning accuracy | Movement of large masses with guides positioned far apart | Backlash-free drive systems for high-precision machines | Backlash-free drive systems for high-precision machines and moving large masses |

Master/slave (electrically preloaded)

Backlash-free rack and pinion or pinion gear ring drives can be realized with the master/slave. In principle, these are two drives operated synchronously like a gantry system (electric master shaft). Here, the control system establishes a digital connection between the drives with an adjustable and mostly constant torque difference. The master/slave and the optimum preload can be sized with cymex® 5.

The preload increases the operating rigidity of the drive compared to drives that are not preloaded (better controllability). Electric preload is not dependent on geometric manufacturing and installation tolerances. Drives in a master/slave arrangement can be adjusted with extreme flexibility and ensure maximum precision throughout the entire service life as well as maximum dynamics.

By contrast, manufacturing and installation inaccuracies in mechanically preloaded systems change the preload distance. Preloading can only be adjusted for one pinion position on the rack or gear ring. In any other position of the pinion on the rack or gear ring, preload force fluctuations of more than $\pm 50\%$ may occur with the usual tolerances.

Flexibilities must be integrated into the system so that constraining forces resulting from tolerance fluctuations occurring during mechanical preloading of the drive system do not cause any damage. Although these flexibilities compensate for any geometric deviations, the positioning accuracy and dynamic behavior of the system do suffer as a result. High-precision and dynamic machines require rack and pinion drives with electrical preload.

Preload F_v

The preload F_v of an electrically preloaded rack and pinion system (master/slave) is the force with which the two preloaded drives exert pressure on the rack and one another at zero speed without any influence from external forces. Ideally, the preload is defined based on the required process parameters. Alternatively, the preload can be estimated based on experience with similar machines. In servo control systems, the preload for a drive is usually entered as a percentage of the motor nominal torque or the reference torque. The preload on the load side calculated for the process can be recalculated using the gearbox ratio without taking into account the degree of efficiency on the motor side.

$$\pm F_v \cdot \frac{d}{2} \cdot \frac{1}{i} = \pm T_{v, \text{motor}}$$

$$\frac{T_v}{T_{N, \text{motor}}} = \text{Preload}[\%]$$

$$T_{N, \text{motor}} = \text{Motor nominal torque}$$

Loads

The tangential or feed force F_t transferred by the linear system is essentially comprised of the following components under consideration of the system efficiency:

Acceleration force F_a

Horizontal axes: $F_a = m \cdot a$

Vertical axes: $F_a = m \cdot (a+g)$

with:

m ... movable mass

a ... acceleration

g ... gravity

Process force F_p

The machine or system developer must determine the process force F_p for the respective application.

Frictional force F_r

$$F_r = m \cdot g \cdot \mu$$

Empirical values from known applications are frequently used for friction value F_r or friction value μ .

Preload force F_v

For preloaded rack and pinion systems (e.g. electrically preloaded master/slave systems), the pretension between the drives must be taken into consideration.

System efficiency η_s

The efficiency of all system components must be taken into consideration when sizing rack and pinion systems. The degrees of efficiency specified by WITTENSTEIN alpha always relate to a specific working point. The system efficiency of a rack and pinion system is influenced among others by the feed force, feed speed, temperature, preload force and lubricating conditions.

$$\eta_s = \eta_1 \cdot \eta_2 \cdot \dots \cdot \eta_n$$

Bearing of the output pinion

WITTENSTEIN alpha always uses bearings in a cantilever manner for output pinions. The bearing in a cantilever manner allows greater freedom in configuring the drive system (see Design for X, page 140) and sizing the mounting base. Load distribution and rigidity are controlled reliably in the statically defined system and optimized for rack and pinion applications.

Design constraints in the pinion geometry and restrictions regarding installation space are generally encountered on systems with a counter bearing. The static redundancy of the system results in technical shortcomings such as unpredictable load distribution, ineffectiveness of the counter bearing due to radial bearing clearance, preload on the pinion shaft due to position deviations at the different bearing points as well as additional lubrication and sealing points on the counter bearing.

The load distribution in the statically redundant system with counter bearing is dependent on the rigidity of the system components as well as the manufacturing and installation tolerances achieved. If the design is more rigid, the required geometric tolerances are more demanding. Conversely, if the design is more flexible, the positioning accuracy and dynamic behavior of the machine will suffer.



Compendium

Case hardening

In addition to induction-hardened racks, WITTENSTEIN alpha offers a wide range of high-performance case-hardened racks. Case hardening produces a sufficient strength profile. The perfect combination of a close contour hardened edge layer and tough core structure generates maximum flank and tooth strength. The high-quality base material and subsequent case hardening enable the transmission of extremely high feed forces.

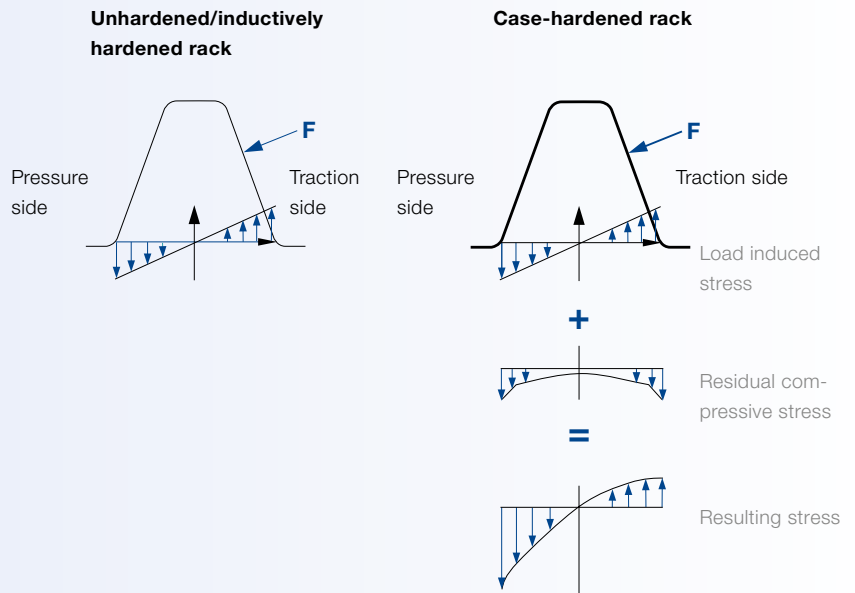

Bolt connection

In addition to the long-established bolt pattern of unhardened and induction-hardened racks with 125 mm hole distance, WITTENSTEIN alpha has introduced an optimized bolt pattern with 62.5 mm hole distance for transmitting the high feed forces of case-hardened racks. The larger number of screws with the same screw diameter, the more favorable clamping length ratio and consistent rack geometry lead to a compression

which is distributed evenly along the entire length of the rack. The perfect friction connection prevents gliding effects and ensures that even the highest feed forces are transmitted reliably. Although the material thickness between the tothing and fastening hole remains unchanged, the area around the tooth root is not weakened and its strength does not diminish.

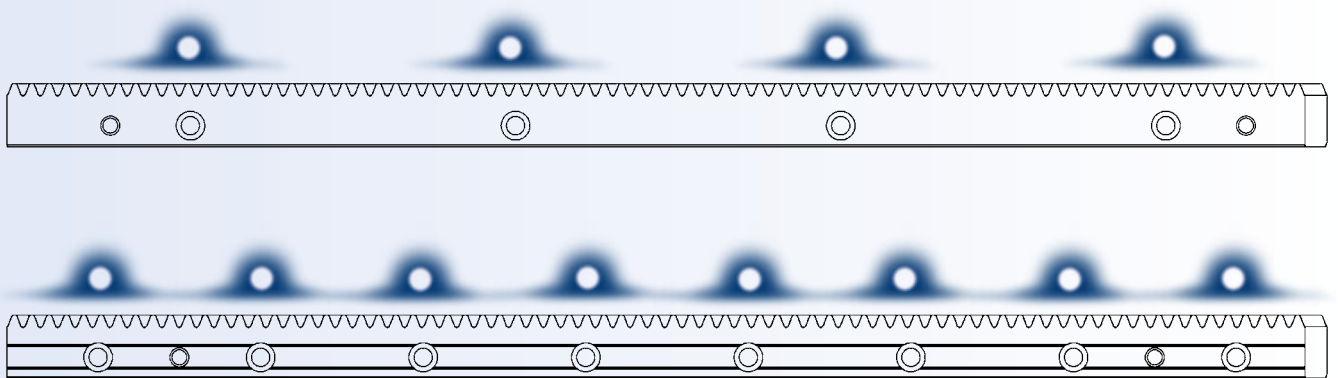

Compression distribution determined in technical tests using pressure measuring foils with conventional and optimized bolt pattern.

Pin connection

Racks are pinned to protect against overloading. The pins prevent the rack from sliding at high loads e.g. during a crash or emergency situation. This can cause an alignment or pitch error at the transition between two racks and ultimately result in

the failure of the entire rack and pinion drive system. In safety-relevant axes that are subject to extreme loads, the pinning of racks is essential in eliminating the risk of potential failure as well as availability risks.

Module m , pitch p

The module is a length which describes the size of the tothing. It cannot be measured directly at the gear or rack, but is calculated according to the following formula:

$$m_t = \frac{p_t}{\pi} = \frac{d}{z}$$

The reference circle pitch p_t is the length of the pitch circle curve (gear) or the pitch line (rack) between two consecutive right or left flanks of the same name.

For helical tothing

$$m_t = \frac{m_n}{\cos\beta} \quad p_t = \frac{p_n}{\cos\beta}$$

For straight tothing

$$m = m_t = m_n \quad p = p_t = p_n$$

Flank direction, helix angle

If the tooth flanks on a tothing run from the bottom left (right) to top right (left) viewed from the tooth tips, the flank direction is towards the right (left). A helix angle associated with a

right-handed flank direction is considered positive while a helix angle associated with a left-handed flank direction is considered negative.



Left



Straight



Right

Pitch circle diameter

The pitch circle diameter of the output pinion is calculated as follows:

$$d = m_t \cdot z = \frac{m_n}{\cos\beta} \cdot z$$

Unlike a spur gear pairing, in the special case of rack and pinion the pitch diameter is equal to the pitch circle diameter.

Profile correction

Some output pinions from WITTENSTEIN alpha are available with a positive profile correction. Here the basic profile is moved from the pitch circle towards the tooth tip, which produces a modified tooth shape with larger tip and root circle diameters. The pitch circle diameter remains unchanged. For pinions with a small number of teeth, profile correction is used to avoid an

undercut and increase the tooth strength. Profile correction is calculated by multiplying the addendum modification factor x by the normal module m_n of the tothing. The profile correction changes the axis distance (see "Axis distance A between rack and pinion").

Compendium

Axis distance A between rack and pinion

The axis distance between the rack and pinion is measured from the rotation axis of the pinion to the rear surface of the rack. It consists of an axis component of the pinion a_1 and an axis distance component of the rack a_2 .

The following applies for toothings with a standard basic tooth profile according to DIN 867:

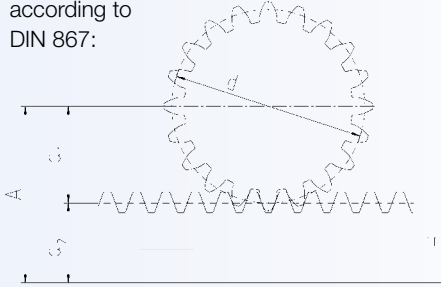

$$A = a_1 + a_2$$

with

$$a_1 = \frac{d}{2} + x \cdot m_n$$

and

$$a_2 = H - m_n$$

We would be happy to advise you on how to determine the axle distance between the pinion and gear ring.

Max. feed speed v_{2Max}

The max. feed speed of the rack and pinion system v_{2Max} [m/min] is calculated using the maximum output rpm of the gearbox n_{1Max} [rpm] (see gearbox catalog), the gearbox ratio i [-] and the pitch circle diameter of the output pinion d [m]:

$$v_{2Max} = \pi \cdot \frac{n_{1Max}}{i} \cdot d$$

Bearing forces

The tooth force components and bearing reactions are calculated at the mesh point of the rack and pinion as follows:

- Tangential and feed force $F_{2t} = \frac{T_2}{d/2}$
- Axial force $F_{2q} = \frac{F_{2t}}{\cos \beta} \cdot \tan \alpha$
- Radial force component $F_{2r} = \sqrt{F_{2q}^2 + F_{2t}^2}$

The radial force on the gearbox is calculated using tangential force F_{2t} and radial force component F_{2q} :

$$F_{2r} = \sqrt{F_{2q}^2 + F_{2t}^2}$$

The following approximately applies for toothings with standard basic rack tooth profile according to DIN 867:

$$F_{2r} \approx \frac{1,064}{\cos \beta} \cdot F_{2t}$$

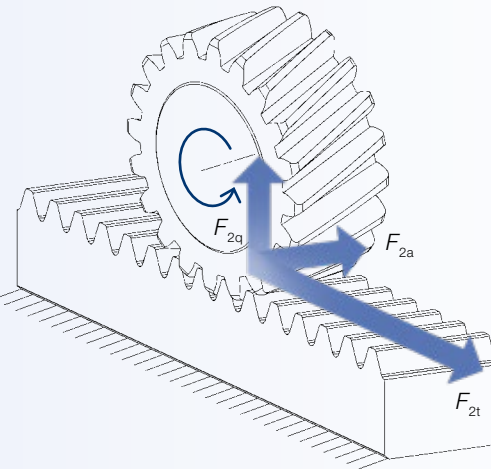

Design for X

The rack and pinion system can be optimized for different properties by varying the pinion diameter. Preferred systems of WITTENSTEIN alpha always represent the perfect compromise between transmittable feed force, linear system rigidity and attainable speed. The bearing in a cantilever manner and standardized interfaces on a wide selection of existing output pinions allow WITTENSTEIN alpha to react flexibly to the requirements in the respective application.

Design for Speed



Speed

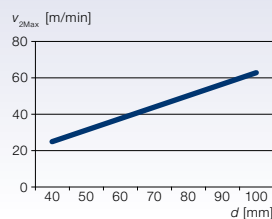

Design for Feed Force



Feed Force

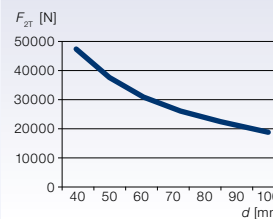

Design for Rigidity



Rigidity

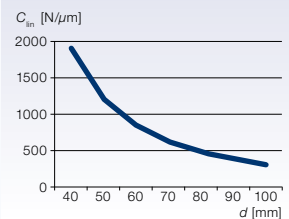

Linear system rigidity C_{lin}

The linear system rigidity of a rack and pinion system is essentially comprised of the following influencing factors:

Torsional rigidity, $C_{t21, lin}$



Tilting rigidity, $C_{2K, lin}$

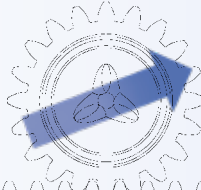

Engaging spring rigidity, C_y



The system rigidity is calculated by adding the reciprocals of all individual rigidity values:

$$\frac{1}{C_{lin}} = \frac{1}{C_{t21, lin}} + \frac{1}{C_{2K, lin, t}} + \frac{1}{C_{2K, lin, r}} + \frac{1}{C_y}$$

Rigidity is usually measured at relatively high loads to exclude any influence from friction and backlash.

Apart from the actual drive components, the overall system rigidity is essentially influenced by the mounting base for the components on the machine as well as the layout and size of the bearings (linear guides):

It is recommended that the mounting base is designed with thick, rigid geometries in order to transfer the extreme rigidity of the rack and pinion system all the way into the tooth mesh. Rigidity of the connection design and linear guides can be considered (perpendicular to the pitch line of the rack) by the rigidity components C_x (in feed direction) and C_y . The linear system rigidity is then:

$$\frac{1}{C_{lin}} = \frac{1}{C_{t21, lin}} + \frac{1}{C_{2K, lin, t}} + \frac{1}{C_{2K, lin, r}} + \frac{1}{C_y} + \frac{1}{C_x} + \frac{1}{C_y}$$

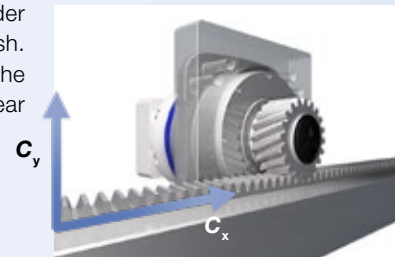

Torsional rigidity C_{T21}

Torsional rigidity C_{T21} [Nm / arcmin] is defined as the quotient of applied torque [Nm] and resulting torsion angle ϕ [arcmin] ($C_{T21} = \Delta T / \Delta \phi$). It consequently shows the torque required to turn the gearbox output shaft with pinion body by one angular minute.

In order to calculate the linear rigidity of the rack and pinion system, the torsional rigidity [Nm / arcmin] must be converted to its linear component [N / μm]:

$$C_{T21, lin} = C_{T21} \cdot \frac{360 \cdot 60 \text{ arc min}}{0.5 \cdot \pi \cdot d^2} \quad d \text{ in mm}$$

Compendium

Tilting rigidity C_{2K}

The tilting rigidity [Nm / arcmin] C_{2K} of the gearbox in the rack and pinion system consists of the bending rigidity of the output or pinion shaft and the rigidity of the output bearing. It is defined as the quotient of tilting moment M_{2K} [Nm] and tilting angle ϕ [arcmin] ($C_{2K} = M_{2K} / \phi$). Tangential (in feed direction) and radial (perpendicular to the pitch line of the rack) tilting rigidity components [N / μm] can be used to calculate the total linear rigidity of the rack and pinion system.

The following simplified calculation model has been prepared to convert the tangential and radial tilting rigidity component analog to the tilting torque for gearboxes:

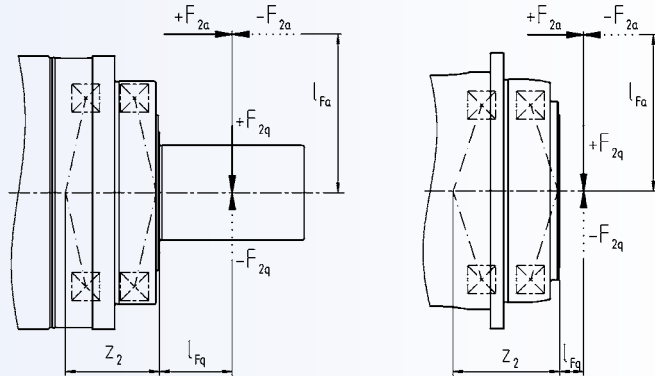

$$C_{2K,lin,t} = \frac{C_{2K} \cdot 60 \cdot 180}{(z_2 + l_{Fq})^2 \cdot \pi}$$

$$C_{2K,lin,r} = \frac{C_{2K} \cdot 60 \cdot 180}{\pi \cdot ((z_2 + l_{Fq}) \cdot \tan^2 \alpha) \cdot \left((z_2 + l_{Fq}) + \frac{\tan \beta}{\tan \alpha} \cdot \frac{d}{2} \right)}$$

C_{2K} ... tilting rigidity of the gearbox in Nm/arcmin
 x_2 and z_2 ... lever arms for tilting torque calculation in mm
 (x_2 relates to application point in center of pinion)
 α ... normal pressure angle in $^\circ$
 β ... helix angle in $^\circ$

d , l_{Fq} and z_2 in mm

Mesh spring rigidity C_Y

The gears of the rack and pinion deform under load. The deformations are variable and change depending on the mesh position. C_Y [N / μm] can be assumed as a temporal average for WITTENSTEIN alpha rack and pinion systems with good approximation.

$$C_Y = 20 \frac{N}{\mu\text{m} \cdot \text{mm}} \cdot B$$

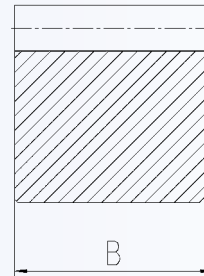

Dynamic rigidity

Modern servo controls make it possible to measure the natural frequency of systems. Taking the single mass oscillator model into consideration, the resulting rigidity can be calculated based on this natural frequency and the inertia of the application.

The measured dynamic rigidity is usually different from the total linear system rigidity calculated using the static measurements for individual components because:

- all system components in the power train (drive and machine components) including intermediate interfaces are taken into consideration
- the measurement is usually made at an operating point with small loads, unlike static rigidity measurements

Natural frequency f_E

The natural frequency f_E of the rack and pinion system is a characteristic variable relating to the dynamic behavior of the machine. The natural frequency is calculated using the linear system rigidity C_{lin} of the rack and pinion system and the moving mass m :

$$f_E = \frac{1}{2 \cdot \pi} \cdot \sqrt{\frac{C_{lin}}{m}}$$

A simplified model of a single mass oscillator forms the basis of this calculation. This simplification has proven to be suitable and it allows the effective comparisons between different applications.

Mesh frequency f_z

The mesh frequency f_z [Hz] may cause vibration problems in an application, especially if the excitation frequency corresponds to a natural frequency of the application.

The mesh frequency for planetary gearboxes of WITTENSTEIN alpha can be calculated using the formula $f_z = 1.8 \cdot n_2$ f_z in Hz
 n_2 in rpm

On planetary gearboxes from WITTENSTEIN alpha, it is independent of the ratio (exception: gearboxes with ratio $i = 8$).

The mesh frequency of the rack and pinion tooth mesh is calculated using the formula $f_z = \frac{n_2}{60} \cdot z$ f_z in Hz
 n_2 in rpm

Emergency stop feed force F_{2Not}

The emergency stop feed force F_{2Not} is the maximum permitted load for the rack and pinion system. It can be reached a max. of 1000 times during the service life of the system and must never be exceeded.

Depending on the configuration of the rack and pinion system, the emergency stop feed force is limited by different system components or system variables. The emergency stop torque T_{2Not} specified in the gearbox data must not be applied to the rack and pinion system if the limit value of other properties such as the permitted tilting torque of the gearbox would be exceeded.

Smooth operation

Smooth operation is a configuration characteristic for pinions and racks manufactured by WITTENSTEIN alpha. It describes the properties of the toothing related to operating noise and the occurrence of dynamic additional forces. Smooth operation

is influenced primarily by periodic changes in the tooth spring rigidity (it fluctuates more on straight toothing than helical toothing), the toothing quality, profile and flank corrections as well as the surfaces of the tooth flanks.

Positioning accuracy (geometric)

Positioning accuracy is a configuration characteristic for pinions and racks manufactured by WITTENSTEIN alpha. It essentially represents the geometric deviations of the toothing components.

The geometric positioning accuracy of the overall system is mainly influenced by the following deviations:

- Gearbox torsional backlash
- Gearbox synchronous run
- Total cumulative pitch deviation or concentricity deviation of the pinion
- Total cumulative pitch deviation of the rack
- Measurement over pins deviation of the rack

Load-dependent deviations are added to the geometric deviations (see linear system rigidity).

Basic Line gearbox overview



| Product type | | CP | CPS | CPK | CPSK | CVH | CVS |
|---|------------|------|------|------|------|---------|---------|
| Version | | MF | MF | MF | MF | MF / MT | MF / MT |
| Ratio ^{c)} | min. $i =$ | 3 | 3 | 3 | 3 | 7 | 7 |
| | max. $i =$ | 100 | 100 | 100 | 100 | 40 | 40 |
| Max. torsional backlash [arcmin] ^{c)} | Standard | ≤ 12 | ≤ 12 | ≤ 13 | ≤ 15 | ≤ 15 | ≤ 15 |
| | Reduced | – | – | – | – | – | – |
| Output type | | | | | | | |
| Smooth shaft | | x | x | x | x | – | x |
| Shaft with key ^{d)} | | x | x | x | x | – | x |
| Splined shaft (DIN 5480) | | – | – | – | – | – | – |
| Blind hollow shaft | | – | – | – | – | – | – |
| Hollow shaft interface | | – | – | – | – | x | – |
| Keyed hollow shaft | | – | – | – | – | x | – |
| Flanged hollow shaft | | – | – | – | – | – | – |
| Flange | | – | – | – | – | – | – |
| System output | | – | – | – | – | – | – |
| Output on both sides | | – | – | – | – | x | x |
| Input type | | | | | | | |
| Motor-mounted | | x | x | x | x | x | x |
| Self-contained version ^{b)} | | – | – | – | – | – | – |
| Characteristic | | | | | | | |
| Flange with slotted holes | | – | – | – | – | – | – |
| ATEX ^{a)} | | – | – | – | – | – | – |
| Food-grade lubrication ^{a) b)} | | x | x | x | x | x | x |
| Corrosion resistant ^{a) b)} | | – | – | – | – | – | – |
| Optimized mass inertia ^{a)} | | – | – | – | – | – | – |
| System solutions | | | | | | | |
| Linear system (rack/pinion) | | – | – | – | – | – | – |
| Servo actuator | | – | – | – | – | – | – |
| Accessories (please refer to the product pages for further options) | | | | | | | |
| Coupling | | x | x | x | x | – | x |
| Shrink disc | | – | – | – | – | x | – |
| Mounting ring | | – | – | – | – | – | – |

^{a)} Power reduction: technical data available on request

^{b)} Please contact WITTENSTEIN alpha

^{c)} In relation to reference sizes

^{d)} Power reduction: Please use our sizing software cymex[®] for a detailed sizing – www.wittenstein-cymex.com

Value Line gearbox overview



| Product type | | NP | NPL | NPS | NPT | NPR | NPK | NPLK | NPSK | NPTK | NPRK | NVH | NVS | HDV |
|---|------------|---------|---------|---------|---------|---------|------|------|------|------|------|-----|-----|---------|
| Version | | MF / MA | MF / MA | MF / MA | MF / MA | MF / MA | MF | MF | MF | MF | MF | MF | MF | MF / MT |
| Ratio ^{a)} | min. $i =$ | 3 | 3 | 3 | 3 | 3 | 3 | 3 | 3 | 3 | 3 | 4 | 4 | 4 |
| | max. $i =$ | 100 | 100 | 100 | 100 | 100 | 100 | 100 | 100 | 100 | 100 | 400 | 400 | 400 |
| Max. torsional backlash [arcmin] ^{a)} | Standard | ≤ 8 | ≤ 8 | ≤ 8 | ≤ 8 | ≤ 8 | ≤ 11 | ≤ 11 | ≤ 11 | ≤ 11 | ≤ 11 | ≤ 6 | ≤ 6 | ≤ 10 |
| | Reduced | - | - | - | - | - | - | - | - | - | - | - | - | - |
| Output type | | | | | | | | | | | | | | |
| Smooth shaft | | x | x | x | - | x | x | x | x | - | x | - | x | x |
| Shaft with key ^{d)} | | x | x | x | - | x | x | x | x | - | x | - | x | x |
| Splined shaft (DIN 5480) | | - | x | x | - | x | - | x | x | - | x | - | - | - |
| Blind hollow shaft | | - | - | - | - | - | - | - | - | - | - | - | - | - |
| Hollow shaft interface | | - | - | - | - | - | - | - | - | - | - | x | - | - |
| Keyed hollow shaft | | - | - | - | - | - | - | - | - | - | - | x | - | - |
| Flanged hollow shaft | | - | - | - | - | - | - | - | - | - | - | - | - | - |
| Flange | | - | - | - | x | - | - | - | - | x | - | - | - | - |
| System output | | - | - | - | - | - | - | - | - | - | - | - | - | - |
| Output on both sides | | - | - | - | - | - | - | - | - | - | - | x | x | - |
| Input type | | | | | | | | | | | | | | |
| Motor-mounted | | x | x | x | x | x | x | x | x | x | x | x | x | x |
| Self-contained version ^{b)} | | - | - | - | - | - | - | - | - | - | - | - | - | - |
| Characteristic | | | | | | | | | | | | | | |
| Flange with slotted holes | | - | - | - | - | x | - | - | - | - | x | - | - | - |
| ATEX ^{a)} | | - | - | - | - | - | - | - | - | - | - | - | - | - |
| Food-grade lubrication ^{a) b)} | | x | x | x | x | x | x | x | x | x | x | x | x | x |
| Corrosion resistant ^{a) b)} | | - | - | - | - | - | - | - | - | - | - | x | x | x |
| Optimized mass inertia ^{a)} | | - | - | - | - | - | - | - | - | - | - | - | - | - |
| System solutions | | | | | | | | | | | | | | |
| Linear system (rack/pinion) | | x | x | x | - | x | x | x | x | - | x | - | x | - |
| Servo actuator | | - | - | - | - | - | - | - | - | - | - | - | - | x |
| Accessories (please refer to the product pages for further options) | | | | | | | | | | | | | | |
| Coupling | | x | x | x | - | x | x | x | x | - | x | - | x | - |
| Shrink disc | | - | - | - | - | - | - | - | - | - | - | x | - | - |
| Mounting ring | | - | - | - | - | - | - | - | - | - | - | - | - | - |

^{a)} Power reduction: technical data available on request

^{b)} Please contact WITTENSTEIN alpha

^{c)} In relation to reference sizes

^{d)} Power reduction: Please use our sizing software cymex® for a detailed sizing – www.wittenstein-cymex.com

Advanced Line gearbox overview



| Product type | | SP+ | SP+ HIGH SPEED | SP+ HIGH SPEED friction optimized | TP+ | TP+ HIGH TORQUE | HG+ | SK+ | SPK+ |
|---|----------|-----|-------------------|---|-----|--------------------|-----|-----|-------|
| Version | | MF | MC | MC-L | MF | MA | MF | MF | MF |
| Ratio ^{c)} | min. i = | 3 | 3 | 3 | 4 | 22 | 3 | 3 | 12 |
| | max. i = | 100 | 100 | 10 | 100 | 302.5 | 100 | 100 | 10000 |
| Max. torsional backlash [arcmin] ^{c)} | Standard | ≤ 3 | ≤ 4 | ≤ 4 | ≤ 3 | ≤ 1 | ≤ 4 | ≤ 4 | ≤ 4 |
| | Reduced | ≤ 1 | ≤ 2 | ≤ 2 | ≤ 1 | – | – | – | ≤ 2 |
| Output type | | | | | | | | | |
| Smooth shaft | | x | x | x | – | – | – | x | x |
| Shaft with key ^{d)} | | x | x | x | – | – | – | x | x |
| Splined shaft (DIN 5480) | | x | x | x | – | – | – | x | x |
| Blind hollow shaft | | x | x | x | – | – | – | – | x |
| Hollow shaft interface | | – | – | – | – | – | x | – | – |
| Keyed hollow shaft | | – | – | – | – | – | – | – | – |
| Flanged hollow shaft | | – | – | – | – | – | – | – | – |
| Flange | | – | – | – | x | x | – | – | – |
| System output | | – | – | – | x | x | – | – | – |
| Output on both sides | | – | – | – | – | – | x | x | x |
| Input type | | | | | | | | | |
| Motor-mounted | | x | x | x | x | x | x | x | x |
| Self-contained version ^{b)} | | x | – | – | x | – | – | – | – |
| Characteristic | | | | | | | | | |
| Flange with slotted holes | | x | – | – | – | – | – | – | – |
| ATEX ^{a)} | | x | x | – | – | – | x | x | – |
| Food-grade lubrication ^{a) b)} | | x | x | x | x | x | x | x | x |
| Corrosion resistant ^{a) b)} | | x | x | x | x | x | x | x | x |
| Optimized mass inertia ^{a)} | | x | x | x | x | x | – | – | – |
| System solutions | | | | | | | | | |
| Linear system (rack/pinion) | | x | x | – | x | x | – | x | x |
| Servo actuator | | x | – | – | x | x | – | – | – |
| Accessories (please refer to the product pages for further options) | | | | | | | | | |
| Coupling | | x | x | x | x | x | – | x | x |
| Shrink disc | | x | x | x | – | – | x | – | x |
| Mounting ring | | – | – | – | x | x | – | – | – |

^{a)} Power reduction: technical data available on request

^{b)} Please contact WITTENSTEIN alpha

^{c)} In relation to reference sizes

^{d)} Power reduction: Please use our sizing software cymex® for a detailed sizing – www.wittenstein-cymex.com



| TK+ | TPK+ | TPK+ HIGH TORQUE | SC+ | SPC+ | TPC+ | VH+ | VS+ | VT+ | DP+ | HDP+ |
|-----|-------|---------------------|-----|------|------|-----|-----|-----|---------|------|
| MF | MF | MA | MF | MF | MF | MF | MF | MF | MF / MA | MA |
| 3 | 12 | 66 | 1 | 4 | 4 | 4 | 4 | 4 | 16 | 22 |
| 100 | 10000 | 5500 | 2 | 20 | 20 | 400 | 400 | 400 | 55 | 55 |
| ≤ 4 | ≤ 4 | ≤ 1.3 | ≤ 4 | ≤ 4 | ≤ 4 | ≤ 3 | ≤ 3 | ≤ 3 | ≤ 3 | ≤ 1 |
| - | ≤ 2 | - | - | ≤ 2 | ≤ 2 | ≤ 2 | ≤ 2 | ≤ 2 | ≤ 1 | - |

| | | | | | | | | | | |
|---|---|---|---|---|---|---|---|---|---|---|
| - | - | - | x | x | - | - | x | - | - | - |
| - | - | - | x | x | - | - | x | - | - | - |
| - | - | - | - | x | - | - | x | - | - | - |
| - | - | - | - | x | - | - | - | - | - | - |
| - | - | - | - | - | - | x | - | - | - | - |
| - | - | - | - | - | - | x | - | - | - | - |
| x | - | - | - | - | - | - | - | x | - | - |
| - | x | x | - | - | x | - | - | - | x | x |
| - | x | x | - | - | x | - | - | - | - | - |
| x | x | x | - | - | - | x | x | - | - | - |

| | | | | | | | | | | |
|---|---|---|---|---|---|---|---|---|---|---|
| x | x | x | x | x | x | x | x | x | x | x |
| - | - | - | - | - | - | - | - | - | - | - |

| | | | | | | | | | | |
|---|---|---|---|---|---|---|---|---|---|---|
| - | - | - | - | - | - | - | - | - | - | - |
| x | - | - | - | - | - | - | - | - | - | - |
| x | x | x | x | x | x | x | x | x | x | x |
| x | x | x | - | - | - | x | x | x | x | x |
| - | - | - | - | - | - | - | - | - | x | x |

| | | | | | | | | | | |
|---|---|---|---|---|---|---|---|---|---|---|
| x | x | x | x | x | x | - | x | x | - | - |
| - | - | - | - | - | - | - | - | - | - | - |

| | | | | | | | | | | |
|---|---|---|---|---|---|---|---|---|---|---|
| x | x | x | x | x | x | - | x | x | - | - |
| - | - | - | - | x | - | x | - | - | - | - |
| - | - | - | - | - | - | - | - | - | x | - |

Premium Line gearbox overview



| Product type | | XP+ | RP+ | XPK+ | RPK+ | XPC+ | RPC+ |
|---|------------|----------|----------|----------|------------|----------|------------|
| Version | | MF / MC | MF / MA | MF | MA | MF | MA |
| Ratio ^{c)} | min. $i =$ | 3 | 22 | 12 | 48 | 4 | 22 |
| | max. $i =$ | 100 | 220 | 1000 | 5500 | 20 | 55 |
| Max. torsional backlash [arcmin] ^{c)} | Standard | ≤ 3 | ≤ 1 | ≤ 4 | ≤ 1.3 | ≤ 4 | ≤ 1.3 |
| | Reduced | ≤ 1 | – | ≤ 2 | – | ≤ 2 | – |
| Output shape | | | | | | | |
| Smooth shaft | | x | – | x | – | x | – |
| Shaft with key ^{d)} | | x | – | x | – | x | – |
| Splined shaft (DIN 5480) | | x | – | x | – | x | – |
| Blind hollow shaft | | x | – | x | – | x | – |
| Hollow shaft interface | | – | – | – | – | – | – |
| Keyed hollow shaft | | – | – | – | – | – | – |
| Flanged hollow shaft | | – | – | – | – | – | – |
| Flange | | – | x | – | x | – | x |
| System output | | x | x | x | x | x | x |
| Output on both sides | | – | – | – | – | – | – |
| Input type | | | | | | | |
| Motor-mounted | | x | x | x | x | x | x |
| Self-contained version ^{b)} | | x | – | – | – | – | – |
| Characteristic | | | | | | | |
| Flange with slotted holes | | x | x | x | x | x | x |
| ATEX ^{a)} | | – | – | – | – | – | – |
| Food-grade lubrication ^{a) b)} | | x | x | x | x | x | x |
| Corrosion resistant ^{a) b)} | | – | – | – | – | – | – |
| Optimized mass inertia ^{a)} | | x | x | – | – | – | – |
| System solutions | | | | | | | |
| Linear system (rack / pinion) | | x | x | x | x | x | x |
| Servo actuator | | x | x | – | – | – | – |
| Accessories (please refer to the product pages for further options) | | | | | | | |
| Coupling | | x | – | x | – | x | – |
| Shrink disc | | x | – | x | – | x | – |
| Mounting ring | | – | – | – | – | – | – |

^{a)} Power reduction: technical data available on request

^{b)} Please contact WITTENSTEIN alpha

^{c)} In relation to reference sizes

^{d)} Power reduction: Please use our sizing software cymex[®] for a detailed sizing – www.wittenstein-cymex.com

Servo actuator overview



| Product type | | PBG | PAG | PHG | RPM* | TPM+ DYNAMIC | TPM+ HIGH TORQUE | TPM+ POWER |
|---|------------|----------|----------|----------|-------------------|-----------------|---------------------|---------------|
| Version | | Standard | Standard | Standard | Customer specific | Standard | Standard | Standard |
| Ratio ^{d)} | min. $i =$ | 16 | 16 | 16 | 22 | 16 | 22 | 4 |
| | max. $i =$ | 100 | 100 | 100 | 220 | 91 | 220 | 100 |
| Max. torsional backlash ^{d)} [arcmin] | Standard | ≤ 6 | ≤ 3 | ≤ 3 | ≤ 1 | ≤ 3 | ≤ 1 | ≤ 3 |
| | Reduced | ≤ 3 | ≤ 1 | ≤ 1 | – | ≤ 1 | ≤ 1 | ≤ 1 |
| Output shape | | | | | | | | |
| Smooth shaft | | x | – | x | – | – | – | – |
| Shaft with key ^{d)} | | x | – | x | – | – | – | – |
| Splined shaft (DIN 5480) | | x | – | x | – | – | – | – |
| Blind hollow shaft | | – | – | – | – | – | – | – |
| Hollow shaft interface | | – | – | – | – | – | – | – |
| Keyed hollow shaft | | – | – | – | – | – | – | – |
| Flanged hollow shaft | | – | – | – | – | – | – | – |
| Flange | | – | x | – | x | x | x | x |
| System output | | – | x | x | x | x | x | x |
| Output on both sides | | – | – | – | – | – | – | – |
| Input type | | | | | | | | |
| Motor-mounted | | – | – | – | – | – | – | – |
| Self-contained version | | – | – | – | – | – | – | – |
| Characteristic | | | | | | | | |
| Flange with slotted holes | | x | – | x | x | – | – | – |
| ATEX ^{a)} | | – | – | – | – | – | – | – |
| Food-grade lubrication ^{a) b)} | | x | x | x | x | x | x | x |
| Corrosion resistant ^{a) b)} | | – | – | – | – | x | x | x |
| Optimized mass Inertia ^{a)} | | – | – | – | – | – | – | – |
| System solutions | | | | | | | | |
| Linear system (rack / pinion) | | x | x | x | x | x | x | x |
| Accessories (please refer to the product pages for further options) | | | | | | | | |
| Coupling | | x | x | – | – | x | x | x |
| Shrink disc | | x | – | – | – | – | – | – |
| Power cable, signal cable, hybrid cable | | x | x | x | x | x | x | x |

^{a)} Power reduction: technical data available on request

^{b)} Please contact WITTENSTEIN alpha

^{c)} In relation to reference sizes

^{d)} Power reduction: Please use our sizing software cymex® for a detailed sizing – www.wittenstein-cymex.com

Assembly of racks

INIRA® pin bore

All racks are dimensionally identical and available in the INIRA® variant in the Advanced and Premium Linear Systems.

The INIRA® pin hole is manufactured in one set up together with threaded holes in the machine bed. The position can be determined using the adjacent tables.

| Module [mm] | h_B [mm] | h_p [mm] | d_p [mm] |
|-------------|------------|------------|------------|
| 2 | 8 | 12 | 6H7 |
| 3 | 9 | 14 | 8H7 |
| 4 | 12 | 18 | 10H7 |
| 5 | 12 | 23 | 12H7 |
| 6 | 16 | 23 | 16H7 |

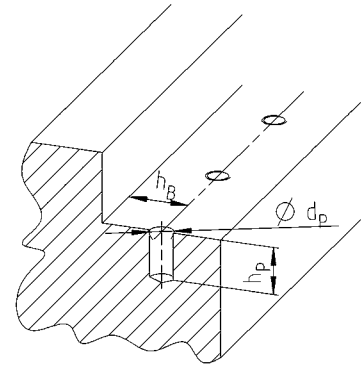

Design of the mounting base

The mounting precision and geometric tolerance of the mounting surfaces in the mounting base depend heavily on the application. Deviations in applications with demanding requirements in terms of positioning accuracy and smooth operation of the drive system should be minimal. Greater deviations are permitted if requirements are less demanding.

Refer to our "alpha rack and pinion system" operating manual for more detailed specifications regarding the mounting surfaces.

Mounting base requirements:

- There is a chamfer on the rack at the transition point between the mounting and rear surface. Recesses can be omitted from the mounting base as a result. The mounting base in the machine must be designed in a way that the milling edge does not collide with the chamfer on the rack (see illustration).
- The mounting base should be designed to be able to clamp the rack easily. This is achieved when the height of the stop surface is more than 50 % of the rack height and a suitable mating surface is available for clamping with a clamping device. If INIRA® is used, the mounting base can be designed much simpler because the clamping system is integrated in the rack.
- The threaded holes for the fastening screws must allow a sufficient screw-in depth, according to the material used for the mounting base. Refer to page 130 for more information on the screw-in depth.

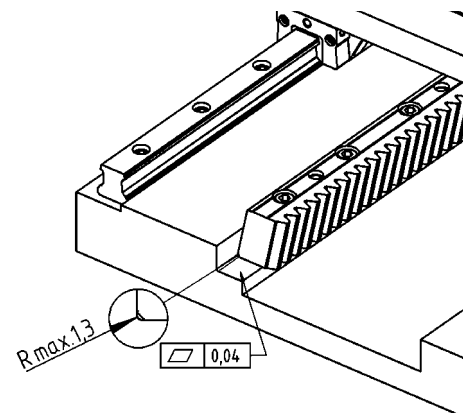

Refer to our operating manual for more information on designing the structure of the entire drive system. Alternatively, get in touch with us - we would be happy to advise you!

Racks – Feed force 4

| | Module [mm] | p_t [mm] | L [mm] | z [] | a [mm] | a_1 [mm] | B [mm] | d [mm] | $d_1^{1)}$ [mm] | D [mm] | h [mm] | $h_B^{2)}$ [mm] | h_D [mm] | H [mm] | l [mm] | l_1 [mm] | L_1 [mm] |
|---|----------------|---------------|-------------|------------|-------------|---------------|-------------|-------------|--------------------|-------------|-------------|--------------------|---------------|-------------|-------------|---------------|---------------|
| Advanced INIRA® Premium INIRA® | 2.0 | 6.666 | 500 | 75 | 58.20 | 375.0 | 24 | 7 | 5.7 | 11 | 22.0 | 8 | 7.0 | 24 | 27.00 | 62.5 | 8.5 |
| | 3.0 | 10.000 | 500 | 50 | 57.40 | 375.0 | 29 | 10 | 7.7 | 15 | 26.0 | 9 | 9.0 | 29 | 26.10 | 62.5 | 10.3 |
| | 4.0 | 13.333 | 493 | 37 | 55.58 | 375.0 | 39 | 12 | 9.7 | 18 | 35.0 | 12 | 11.0 | 39 | 24.33 | 62.5 | 13.8 |
| | 5.0 | 16.666 | 500 | 30 | 53.78 | 375.0 | 49 | 14 | 11.7 | 20 | 34.0 | 12 | 13.0 | 39 | 22.53 | 62.5 | 17.4 |
| | 6.0 | 20.000 | 500 | 25 | 52.00 | 375.0 | 59 | 18 | 15.7 | 26 | 43.0 | 16 | 17.0 | 49 | 20.79 | 62.5 | 20.9 |

- 1) Recommended tolerances for the pin bore 6H7/ 8H7/ 10H7/ 12H7/ 16H7/ 20H7
 2) With INIRA® pinning, note machine bed sketch
 p_t = Transverse pitch
 z = Number of teeth

= Optional = Optional

Racks – Feed force 2 / 3

| | Module [mm] | p_t [mm] | L [mm] | z [] | a [mm] | a_1 [mm] | B [mm] | d [mm] | $d_1^{1)}$ [mm] | D [mm] | h [mm] | $h_B^{2)}$ [mm] | h_D [mm] | H [mm] | l [mm] | l_1 [mm] | L_1 [mm] |
|---|-------------------|---------------|-------------|------------|-------------|---------------|-------------|----------------------|--------------------|-------------|-------------|--------------------|---------------|-------------|-------------|---------------|---------------|
| Advanced INIRA® Premium INIRA® | 2.0 | 6.666 | 500 | 75 | 31.70 | 436.6 | 24 | 7 | 5.7 | 11 | 22.0 | 8 | 7.0 | 24 | 62.50 | 125.0 | 8.5 |
| | 3.0 | 10.000 | 500 | 50 | 35.00 | 430.0 | 29 | 10 | 7.7 | 15 | 26.0 | 9 | 9.0 | 29 | 62.50 | 125.0 | 10.3 |
| | 4.0 | 13.333 | 493 | 37 | 33.30 | 433.0 | 39 | 8 / 10 ⁴⁾ | 7.7 | 15 | 35.0 | 12 | 9.0 | 39 | 62.50 | 125.0 | 13.8 |
| | 5.0 | 16.666 | 500 | 30 | 37.50 | 425.0 | 49 | 14 | 11.7 | 20 | 34.0 | 12 | 13.0 | 39 | 62.50 | 125.0 | 17.4 |
| | 6.0 | 20.000 | 500 | 25 | 37.50 | 425.0 | 59 | 18 | 15.7 | 26 | 43.0 | 16 | 17.0 | 49 | 62.50 | 125.0 | 20.9 |
| | 8.0 ³⁾ | 26.666 | 480 | 18 | 120.0 | 240.0 | 79 | 23 | 19.7 | 34 | 71.0 | 25 | 21.0 | 79 | 60.00 | 120.0 | 28.0 |

- 1) Recommended tolerances for the pin bore 6H7/ 8H7/ 10H7/ 12H7/ 16H7/ 20H7
 2) With INIRA® pinning, note machine bed sketch
 3) Not available as INIRA®
 4) Diameter is defined by the rack execution. Please observe the dimension sheet.
 p_t = Transverse pitch
 z = Number of teeth

= Optional = Optional

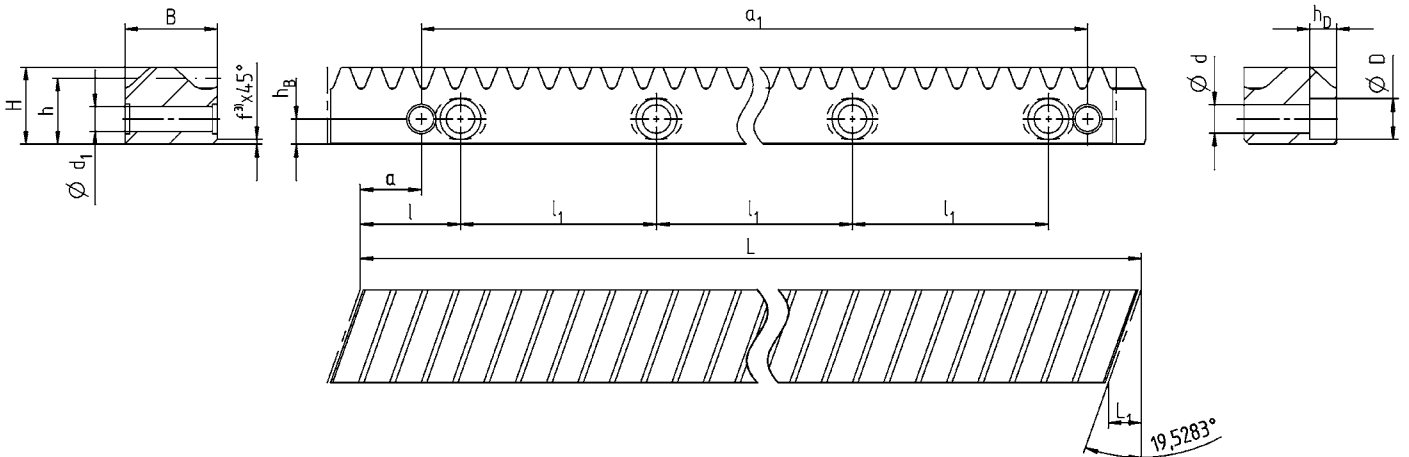

Racks – Feed force 4

| Advanced INIRA® Premium INIRA® | Module [mm] | p_t [mm] | L [mm] | z [] | a [mm] | a_1 [mm] | B [mm] | d [mm] | $d_1^{1)}$ [mm] | D [mm] | h [mm] | $h_B^{2)}$ [mm] | h_D [mm] | H [mm] | l [mm] | l_1 [mm] | L_1 [mm] |
|---|-------------------|---------------|-------------|------------|-------------|---------------|-------------|-------------|--------------------|-------------|-------------|--------------------|---------------|-------------|-------------|---------------|---------------|
| | | 2.0 | 6.666 | 1000 | 150 | 58.22 | 875.0 | 24 | 7 | 5.7 | 11 | 22.0 | 8 | 7.0 | 24 | 26.97 | 62.5 |
| | 3.0 | 10.000 | 1000 | 100 | 57.33 | 875.0 | 29 | 10 | 7.7 | 15 | 26.0 | 9 | 9.0 | 29 | 26.08 | 62.5 | 10.3 |
| | 4.0 | 13.333 | 1000 | 75 | 55.56 | 875.0 | 39 | 12 | 9.7 | 18 | 35.0 | 12 | 11.0 | 39 | 24.31 | 62.5 | 13.8 |
| | 5.0 | 16.666 | 1000 | 60 | 53.78 | 875.0 | 49 | 14 | 11.7 | 20 | 34.0 | 12 | 13.0 | 39 | 22.53 | 62.5 | 17.4 |
| | 6.0 | 20.000 | 1000 | 50 | 52.01 | 875.0 | 59 | 18 | 15.7 | 26 | 43.0 | 16 | 17.0 | 49 | 20.76 | 62.5 | 20.9 |
| | 8.0 ³⁾ | 26.666 | 960 | 36 | 49.96 | 832.0 | 79 | 23 | 19.7 | 34 | 71.0 | 25 | 21.0 | 79 | 17.96 | 64.0 | 28.0 |

1) Recommended tolerances for the pin bore 6H7/ 8H7/ 10H7/ 12H7/ 16H7/ 20H7

2) With INIRA® pinning, note machine bed sketch

3) Not available as INIRA®

p_t = Transverse pitch

z = Number of teeth

 = Optional

 = Optional

Racks – Feed force 2 / 3

| Value Advanced INIRA® Premium INIRA® | Module [mm] | p_t [mm] | L [mm] | z [] | a [mm] | a_1 [mm] | B [mm] | d [mm] | $d_1^{1)}$ [mm] | D [mm] | h [mm] | $h_B^{2)}$ [mm] | h_D [mm] | H [mm] | l [mm] | l_1 [mm] | L_1 [mm] |
|--|-------------------|---------------|-------------|------------|-------------|---------------|-------------|----------------------|--------------------|-------------|-------------|--------------------|---------------|-------------|-------------|---------------|---------------|
| | | 1.5 | 5.000 | 1000 | 200 | 31.70 | 936.6 | 19 | 6 | 5.7 | 10 | 17.5 | 7 | 5.5 | 19 | 62.50 | 125.0 |
| | 2.0 | 6.666 | 1000 | 150 | 31.70 | 936.6 | 24 | 7 | 5.7 | 11 | 22.0 | 8 | 7.0 | 24 | 62.50 | 125.0 | 8.5 |
| | 3.0 | 10.000 | 1000 | 100 | 35.00 | 930.0 | 29 | 10 | 7.7 | 15 | 26.0 | 9 | 9.0 | 29 | 62.50 | 125.0 | 10.3 |
| | 4.0 | 13.333 | 1000 | 75 | 33.30 | 933.4 | 39 | 8 / 10 ⁴⁾ | 7.7 | 15 | 35.0 | 12 | 9.0 | 39 | 62.50 | 125.0 | 13.8 |
| | 5.0 | 16.666 | 1000 | 60 | 37.50 | 925.0 | 49 | 14 | 11.7 | 20 | 34.0 | 12 | 13.0 | 39 | 62.50 | 125.0 | 17.4 |
| | 6.0 | 20.000 | 1000 | 50 | 37.50 | 925.0 | 59 | 18 | 15.7 | 26 | 43.0 | 16 | 17.0 | 49 | 62.50 | 125.0 | 20.9 |
| | 8.0 ³⁾ | 26.666 | 960 | 36 | 119.92 | 720.0 | 79 | 23 | 19.7 | 34 | 71.0 | 25 | 21.0 | 79 | 60.00 | 120.0 | 28.0 |

1) Recommended tolerances for the pin bore 6H7/ 8H7/ 10H7/ 12H7/ 16H7/ 20H7

2) With INIRA® pinning, note machine bed sketch

3) Not available as INIRA®

4) Diameter is defined by the rack execution. Please observe the dimension sheet.

p_t = Transverse pitch

z = Number of teeth

 = Optional

 = Optional

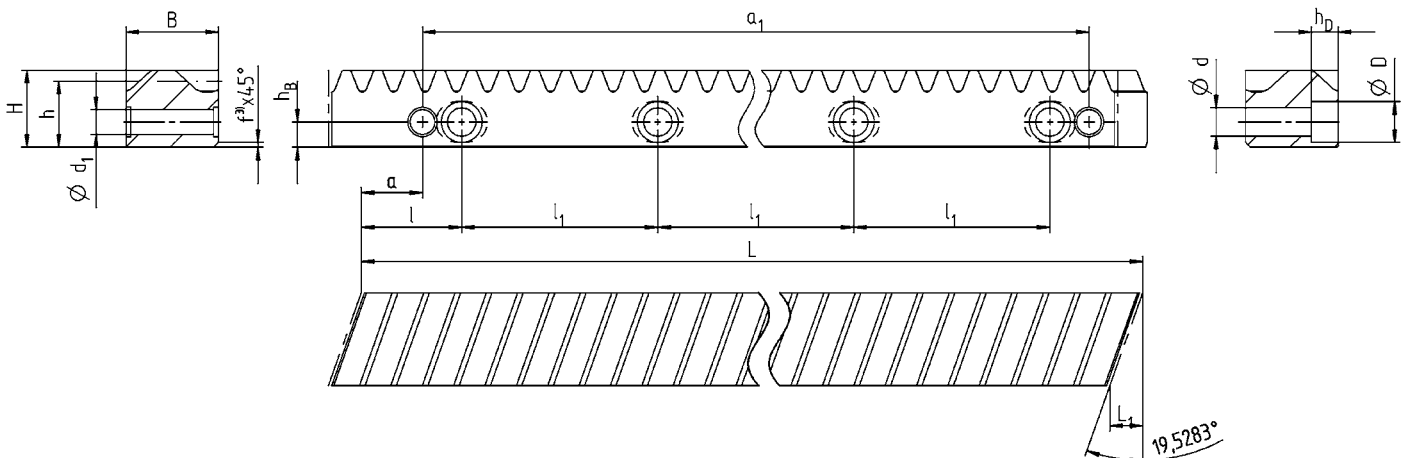

We offer more than just a drive system

Full support for your application:

- Consultation and engineering on site
- Performing complex application calculations
- System design and implementation according to your specific needs
- Support in the form of on-site commissioning and assembly training
- 24h service hotline

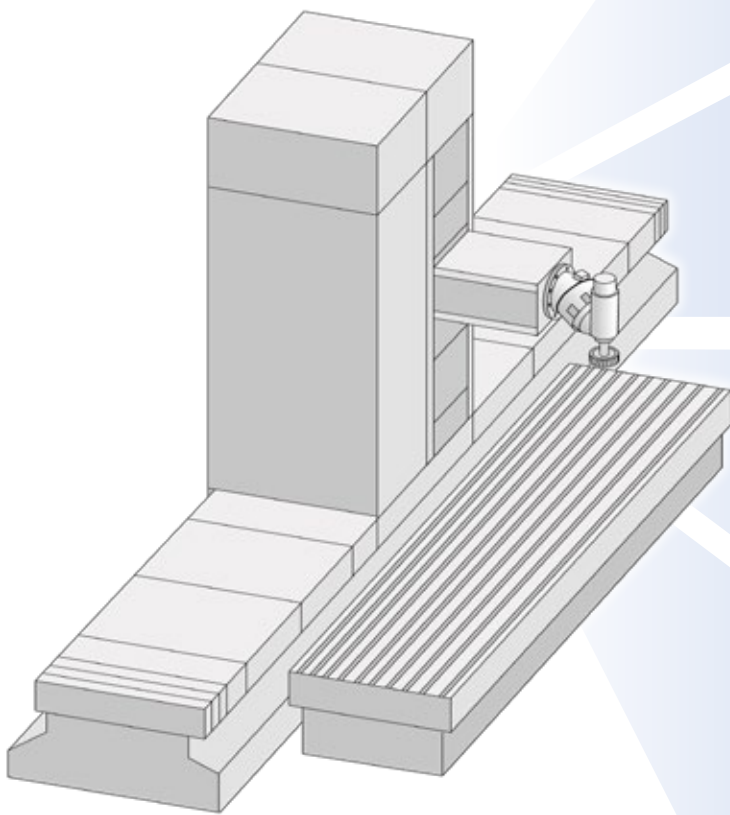
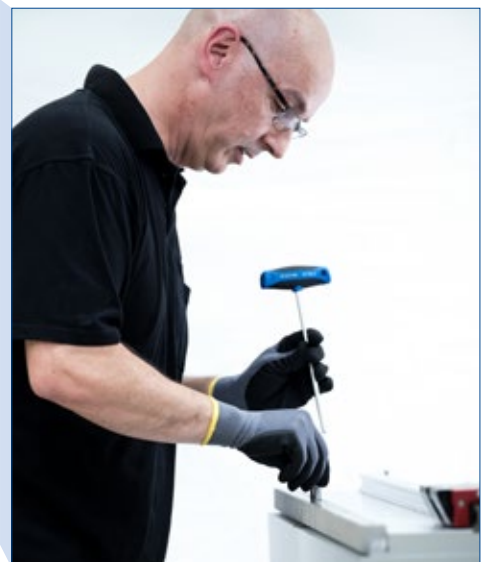
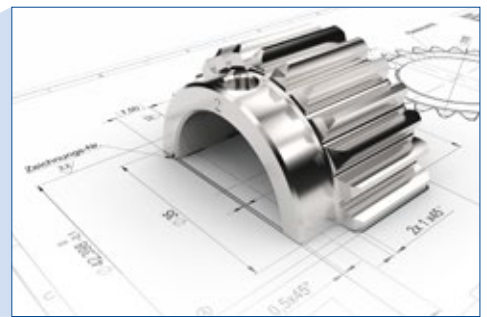

The WITTENSTEIN group – The company and its fields of business



WITTENSTEIN

With approximately 2,900 employees worldwide, WITTENSTEIN SE stands for innovation, precision and excellence in the world of mechatronic drive technology, both nationally and internationally. The group is active in six innovative fields of business. Furthermore, WITTENSTEIN SE is represented by some 60 subsidiaries in around 40 countries in all important technology and sales markets worldwide.



Our fields of expertise

We provide know-how for a host of different sectors:

- Machine and plant construction
- Software development
- Aerospace
- Automotive & E-mobility
- Energy
- Oil & Gas Exploration and Production
- Medical technology
- Measurement and testing technology
- Nanotechnology
- Simulation



alpha



WITTENSTEIN alpha GmbH
High-precision servo drives and linear systems



motion control



WITTENSTEIN motion control GmbH
Customized linear and rotary servo systems



cyber motor



WITTENSTEIN cyber motor GmbH
Highly dynamic servo motors and drive electronics



intens



WITTENSTEIN intens GmbH
Smart drive solutions in and on the human body



aerospace
& simulation



WITTENSTEIN aerospace & simulation GmbH
Mechatronic drive systems for aerospace & simulation



attocube systems AG
Nanoprecision drive and measurement technology solutions



alpha

WITTENSTEIN alpha GmbH
Walter-Wittenstein-Straße 1
97999 Igersheim
Germany

Tel. +49 7931 493-0
24h-Service-Hotline: Tel. +49 7931 493-12900
speedline®: Tel. +49 7931 493-10444
info@wittenstein-alpha.com

Subject to technical changes. alpha Linear Systems

WITTENSTEIN alpha – **Intelligent** drive systems

www.wittenstein-alpha.com

The entire world of drive technology – Catalogs available on request or online at www.wittenstein-alpha.com/catalogs



alpha Advanced Line. Maximum power density and outstanding positioning accuracy for complex applications.



alpha Basic / Value Line. Reliable, flexible and economical solutions for a wide range of applications.



alpha Linear Systems. Precise, dynamic system solutions for every requirement.



alpha Mechatronic Systems. Energy-efficient, versatile and flexible mechatronic drive systems.