

# DENISON HYDRAULICS Jupiter 900 Driver Card Eurocard Version

Series S20-14078-0 Design C/D

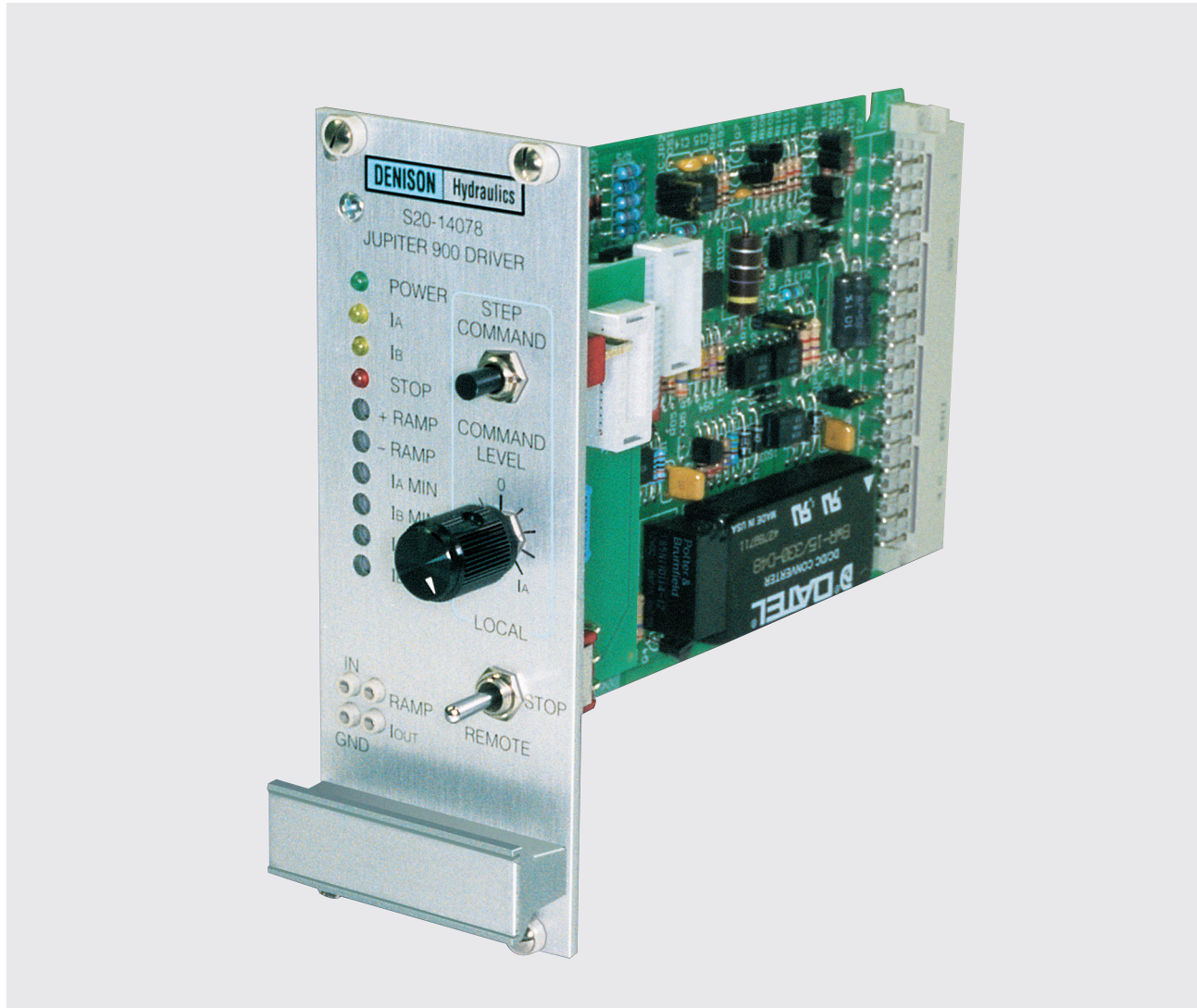

Publ. 9-AM682-A *replaces 9-AM682*

**DENISON** Hydraulics

**MANUFACTURER'S NAME** DENISON HYDRAULICS

**MANUFACTURER'S ADDRESS** 14249 Industrial Parkway  
Marysville, Ohio 43040-9504, USA

**declares that the product**

**PRODUCT NAME** Jupiter 900 Driver Card

**PRODUCT PART NUMBER** S20-14078-0

**conforms to the following product specifications**

**EMC:** EN50081-2: March 1994 generic emissions for heavy industry<sup>1</sup>  
EN55011: 7/1992 radiated or conducted EMI – 30-1000MHz

EN50082-2: 1995 generic immunity for heavy industry<sup>1</sup>  
ENV50140: 8/1993 – 10V/m, 80-1000MHz – Performance Criteria B

EN61000-4-2, IEC801-2 electrostatic discharge (ESD)  
8KV air discharge – Performance Criteria A  
4KV contact discharge – Performance Criteria A

EN61000-4-4: 5/1995 fast transient rejection  
2KV power supply wires – Performance Criteria B

**SUPPLEMENTARY INFORMATION**

The product was tested in an EMC TEST Laboratory in Germany and herewith complies with the EMC Directive 89/336 and the CE Marking requirements.

<sup>1</sup> The product was tested in a typical system configuration with DENISON HYDRAULICS Jupiter Series products or recommended second source products. The tested product was mounted in a NEMA 4 enclosure (or equivalent) and all cables exiting the enclosure were shielded (screened). Enclosure and cable shields were connected to earth ground (PE).

**USA CONTACT**

Office of Director of Quality  
DENISON HYDRAULICS  
14249 Industrial Parkway  
Marysville, Ohio 43040

**EUROPEAN CONTACT**

DENISON HYDRAULICS Sales Office  
or Office of Quality Manager  
DENISON HYDRAULICS GmbH  
Gerresheimer Strasse 9  
D-40721 Hilden  
Deutschland

**See Installation & Operation Guidelines under Procedures.**

**IMPROVEMENTS AND CHANGES  
WORTH NOTING**

1. Improved power supply specification — 22-29VDC(min-max): unit will tolerate overvoltage excursions up to 40 volts.

The old version specified 24-28VDC, (minimum to maximum). If the input voltage accidentally exceeded 30 volts, including any AC peaks, the converter would fail permanently. Mobile applications with battery chargers could exceed the 30 volts; but also fixed industrial applications with unregulated, 28VDC power supplies will readily exceed 35 volts due to AC input tolerance and output load variations.

2. Eliminated the two 1/2 amp Micro-Fuses. The new DC-DC converter has internal short-circuit protection, eliminating the need for fuses. Total current available from  $\pm 15\text{Vdc}$  source is 330mA, that is, onboard and off-board. Unit has over-current protection.
3. Front panel STEP COMMAND is functional in both LOCAL and REMOTE modes. Older versions only worked in LOCAL mode.
4. Added option to permit isolated power source for E-STOP function. This option is factory set to operate as previous versions. If isolated power source is desired, move jumper JP4 from position A-B (internal GND) to B-C (isolated GND) and connect the isolated power ground to terminal C24 E-STOP RET. It made sense to provide this isolation option to the E-STOP function since the SOFT-STOP and REV CMD function can be isolated.

NOTE: Terminal C24 on versions prior to REV. C was REV CMD RET. Terminal C22 is now the REV CMD RET and SOFT-STOP RET. (We ran out of terminals).

5. Added 400 Hz, as a third choice for pulse-width modulation frequency. The factory set is 200Hz, JP2 (A-B). For 400Hz set jumper JP2 to B-C and for 120Hz remove the jumper (store the jumper on one of the pins).
6. The Ramp time minimum values have increased to 0.2 and 0.8 seconds. This should be of little consequence in most application. The ramp function can be shut off if desired.
7. The IA and IB LED's illuminate somewhat proportionately to the output current. This is a good troubleshooting tool.

	<b>PAGE</b>
European EMC Directive 89/336/EEC Declaration of Conformity .....	i
product update information .....	ii
table of contents .....	iii
technical specifications .....	1-2
power supply requirements .....	1
reference voltages .....	1
remote inputs .....	1
operating temperature .....	1
ramp generator .....	1
output driver .....	1
feedback inputs .....	1
input command disable .....	1
emergency stop input .....	1
reverse CMD input .....	1
soft stop input .....	1
LED indicators .....	2
potentiometer adjustments .....	2
front panel local controls .....	2
front panel test points .....	2
mechanical .....	2
I/O connector pin assignment .....	2
product description .....	3
system features .....	3
general .....	3
functional description .....	4-5
input .....	4
output .....	4
PWM frequency .....	4
ramp generator .....	4
front panel controls & indicators .....	4
emergency stop option .....	4
soft stop option .....	5
reverse CMD option .....	5
ramp-at-zero option .....	5
closed-loop-control .....	5
remote operation only .....	5
procedure .....	6
installation & operation guidelines .....	6
set-up procedure .....	6
installation drawings .....	7-9
eurocard holder outline .....	7
power supply outline .....	8
900 driver card outline .....	9
jumper & switch settings .....	9
900 driver functional block diagram .....	10
input signal options diagrams .....	11-12
remote voltage & potentiometer .....	11
current-loop with interlock .....	12
application diagrams .....	13-19
open-loop control scheme .....	13
closed-loop control scheme .....	13
most common application .....	14
open-loop speed w/ hp limit .....	15
closed-loop speed w/ command forward .....	16
closed-loop speed w/ com. forward & hp lmt .....	17
closed-loop speed w/ pi .....	18
closed-loop speed w/ pi & hp lmt .....	19

<b>POWER SUPPLY REQUIREMENTS</b>	22-29VDC @ 1 Amp (nominal)	
<b>REFERENCE VOLTAGES</b>	<i>Available to user</i>	+15VDC @ 250 mA (max.) -15VDC @ 250 mA (max.) +10VDC @ 0.0025 Amps max. -10VDC @ 0.0025 Amps max.
<b>REMOTE INPUTS</b>	<i>Potentiometer</i>	10K Ohms nominal, 5K Ohms minimum
	<i>Input voltage range</i>	±5VDC, ±10VDC
	<i>Input impedance</i>	100K Ohms, 200K Ohms
	<i>Current loop input</i>	4-20mA, ±20mA
	<i>Current loop input impedance</i>	249 Ohms
	<i>Auxiliary voltage input</i>	±10VDC
	<i>Reverse command input</i>	+15 - +24VDC
	<i>Soft stop input</i>	+15 - +24VDC
<b>OPERATING TEMPERATURE RANGE</b>	0-70°C	
<b>RAMP GENERATOR</b>	<i>Switchable (DIP switch)</i>	On or Off
	<i>Positive ramp (rising) range A</i>	0.2-6 sec.
	<i>Positive ramp (rising) range B</i>	0.8-40 sec.
	<i>Negative ramp (falling) range A</i>	0.2-6 sec.
	<i>Negative ramp (falling) range B</i>	0.8-40 sec.
<b>OUTPUT DRIVER</b>	<i>Pulse width modulation (PWM) driver with current feedback and short circuit protection.</i>	
	<i>PWM frequency</i>	120Hz, JP2 position no jumper 200Hz, JP2 position A-B 400Hz JP2 position B-C
	<i>I<sub>(A,B)</sub> minimum</i>	0-460mA
	<i>I<sub>(A,B)</sub> maximum w/24 Ohm load</i>	I <sub>min</sub> - 800mA
<b>FEEDBACK INPUTS</b>	<i>Horsepower limiting command</i>	±10VDC
	<i>Major loop</i>	±10VDC
<b>INPUT COMMAND DISABLE</b>	<i>Gnd to disable</i>	
<b>EMERGENCY STOP INPUT</b>	Apply +15 to 24VDC for normal operation (optical isolation if desired). Remove 24VDC for emergency stop. Remove jumper JP4 for isolated signal source.	
<b>REVERSE CMD INPUT (OPTICALLY ISOLATED)</b>	No connection for normal operation. Apply +15V to 24VDC and GND to reverse command.	
<b>SOFT STOP INPUT (OPTICALLY ISOLATED)</b>	JP3 factory set to position B-C, soft stop disabled. Set JP3 to position A-B to enable soft stop. Apply 15V to 24VDC and GND for normal operation. Remove 24VDC for soft stop.	

**DESCRIPTION**

**LED INDICATORS**

<i>Power</i>	±15VDC supply operational
<i>I<sub>A</sub></i>	Output current to coil A
<i>I<sub>B</sub></i>	Output current to coil B
<i>Stop</i>	Both "A" & "B" coils disabled, same as emergency stop.

**POTENTIOMETER ADJUSTMENTS**

<i>+ Ramp</i>	Adjusts positive ramping time
<i>- Ramp</i>	Adjusts negative ramping time
<i>I<sub>A</sub> Min</i>	Adjusts coil A minimum current
<i>I<sub>B</sub> Min</i>	Adjusts coil B minimum current
<i>I<sub>A</sub> Max</i>	Adjusts coil A maximum current
<i>I<sub>B</sub> Max</i>	Adjusts coil B maximum current

**FRONT PANEL LOCAL CONTROLS**

<i>Local-Stop-Remote switch</i>	Selects the mode of operation for the driver card. Card can be jumpered for remote operation only; set JP1 to B-C.
<i>Command level potentiometer</i>	Adjusts the input command when switched to local mode.
<i>Step command push-button</i>	Forces the local remote input command to zero when pressed. Facilitates ramp adjustment.

**FRONT PANEL TEST POINTS**

<i>In</i>	Input command (±10VDC)
<i>Ramp</i>	Ramp output (±10VDC)
<i>Out</i>	Coil current scaled to ±1mV per ±1mA Coil A is a positive value, Coil B is a negative value
<i>Gnd</i>	Signal ground reference

**MECHANICAL**

<i>Dimensions, eurocard</i>	3U, 100 x 160mm (3.9 x 6.3 in.)
<i>Dimensions, Card w/Front Panel</i>	128.4 H x 193 D x 50.5 W mm (5 H x 7.6 D x 2 W in.)
<i>Connector</i>	DIN 32C, male
<i>Weight</i>	0.22 kg (0.484 Lbs.)

**I/O CONNECTOR PIN ASSIGNMENTS S20-14078**

A2: +10V Ref. @ 2.5mA	C2: Test Point Command In
A4: -10V Ref. @ 2.5mA	C4: Test Point Ramp First-Stage Ampl.
A6: ±5V Command	C6: Test Point Ramp Out
A8: ±10V Command	C8: Test Point Current Out Coil A/B
A10: ±10V AUX Command	C10: Coil A PWM Output
A12: Signal Ground	C12: Coil A Return
A14: Current-Loop In	C14: Ramp-at-Zero Open-Collector Unit
A16: Current-Loop Ret	C16: Command Inverted
A18: Major-Loop Feedback	C18: Coil B PWM Output
A20: HP Limiting Command	C20: Coil B Return
A22: Soft-Stop Input	C22: Soft-Stop Return / Rev. Comm. Ret.
A24: Reverse Command Input	C24: E-Stop Return
A26: Signal Ground	C26: Command Disable CMDDIS/
A28: E-Stop Input	C28: +15V @ 250mA Power Out
A30: DC Power Input	C30: -15V @ 100mA Power Out
A32: Power Ground	C32: Power Ground

**SYSTEM FEATURES**

- Controls 9A electro hydraulic control for Gold Cup Series and premier open loop pumps
- Open or closed loop control (w/options card S20-11716-0)
- Eurocard format (see S20-14087-0 for panel mount version)
- Separately adjustable positive and negative ramps (0.2-40 sec.)
- Multiple input commands
- Remote potentiometer (10K CT)
- $\pm 5\text{VDC}$  and  $\pm 10\text{VDC}$  voltage inputs
- $+4\text{-}20\text{mA}$  and  $\pm 0\text{-}20\text{mA}$  current loop inputs
- Auxiliary inputs
- Soft stop option
- Emergency stop option
- Reverse command option
- Front panel operator controls
- Easy calibration
- LED control indicators
- Potentiometer adjustments
- Special field calibration features
- Special safety features

**GENERAL**

Jupiter driver card S20-14078-0-0 is a bidirectional pulse-width modulated current coil driver used for proportional open-loop control of the 9A electro hydraulic controlled pumps. Input commands to the card may be voltages, current loop, or potentiometer, single ended or differential. Multiple input commands are permitted but must be interlocked by the user to insure that the card is controlled by only one input at a time. The card also features two ranges of positive and negative ramping, remote emergency shutdown control, options for soft stop, emergency stop and reverse command, as well as provisions for closed-loop control with the Jupiter Options Card S20-11716. The driver card is packaged in a 3U eurocard size and may be operated with stand alone DC power supplies or with the Jupiter 900 power supply 762-30026, which provides the required DC power in a panel mount package.

*Open loop control*

The driver card with its power supply accessory is used for open-loop control. It provides multiple input commands, ramping, and front panel set-up controls. The panel mounted power supply, 762-30026, furnishes the driver card with regulated DC power and features screw terminals for simplified panel wiring.

*Closed loop control*

The options card, S20-11716, is used in conjunction with the driver card for precise closed-loop control. It features digital and DC tachometer feedback, horsepower limiting, and PI control of feedback error. A panel mounted eurocard holder with screw terminals is available for easy mounting. Power for the options card is obtained from the driver card's power supply.

**INPUT**

**Local** or **remote** input is selected via a switch located on the front panel. In **local** mode a single-turn front panel **command level** potentiometer provides  $\pm$  full-scale input. **Local** mode is recommended for system set-up process only.

In **remote** mode several user wired input options are available. This mode is the primary method of wiring the card for inputs from standard industrial control sources such as voltage and current-loop signal generators. The user has a choice of voltage, current-loop or potentiometer when using the remote input. Voltage inputs may be  $\pm 5V$ , or  $\pm 10V$ . Current-loop inputs are differential 4-20mA<sup>1</sup> or  $\pm 0-20mA$ . DIP switches on board are for current-loop set-up.

When in **remote** an **auxiliary**  $\pm 10V$  input is available. This input provides the user more input options. With all the remote input options provided, it is the user's responsibility to interlock multiple inputs if driver card is to be controlled by one input at a time.

<sup>1</sup> The **reverse CMD** input can be used to obtain bidirectional operation.

On revision level C and up, the **step command** pushbutton also operates when in **remote** mode permitting accurate ramp time settings on the remote signal that is used in actual operation.

**OUTPUT**

The output stage of the driver card is a two channel PWM (Pulse Width Modulated) current source with current feedback for precise control of the current through the coil regardless of the changes in coil resistance. The two outputs are protected against short circuits across the coil and short circuits to ground.

**PWM FREQUENCY**

The frequency of the **PWM** high current driver is factory set to 200Hz (JP2 A-B). **JP2** allows the frequency to be lowered to 120Hz by removing the **JP2** jumper, or raised to 400Hz by moving **JP2** to position B-C. The 120Hz frequency setting produces more dithering effect and reduces hysteresis.

**RAMP GENERATOR**

Adjustable positive and negative ramping of the output is provided in two ranges of 0.2-6 and 0.8-40 seconds. Ramping on-off and ramping ranges are selected by dip switches on the card. The **command level** potentiometer and the **step command** pushbutton located on the front panel may be used for accurate adjustments of ramp times.

**FRONT PANEL CONTROLS AND INDICATORS**

Key indicators, potentiometer adjustments, switches and test points are brought out to the front panel for monitoring, set-up and calibration purposes. **LEDs** are provided for indicating the status of the power (internal  $\pm 15VDC$  supplies), the coil that is energized and the state of the emergency stop function.

Potentiometer adjustments include  **$\pm$ ramps**, **I<sub>A,B</sub> min** and **I<sub>A,B</sub> max**. Test points are furnished for measurement of the input, output, ramp and signal ground. A **local - stop - remote** switch is provided to switch control of the card from local front panel control to user-wired remote control. **Stop** de-energizes emergency shut-down relay **K1**, removing 24VDC from the **PWM** driver circuit. Jumper **JP1** will allow the card to be placed in **remote** mode and disable the front panel **local - stop - remote** switch, the **step command** push-button and the **command level** potentiometer. The **command level** potentiometer is used in conjunction with the **step command** push-button for set-up and calibration of the driver card. Pressing then releasing the **step command** push-button in local mode triggers the ramping of the output from zero current to the current level set by the **command level** potentiometer, permitting accurate and simple adjustment of both the positive and negative ramp times. On revision level C and up, the **step command** pushbutton also operates when in **remote** mode permitting accurate ramp time settings on the remote signal that is used in actual operation.

**EMERGENCY STOP OPTION**

The emergency stop (E-stop) input controls the K1 relay that provides 24VDC to the output driver stage. Applying logic level +15 to 24VDC to the E-stop enables the driver card output stage. Removing the E-stop signal will abruptly halt the output current. (See **soft-stop** option). In revision level C and up an isolated E-stop signal option is provided. If an isolated E-stop signal is required, remove the JP4 jumper and connect the isolated signal common to terminal C24.



**SOFT STOP OPTION**

The **soft stop** option is used to set the output current to zero at a rate set by the **ramp** circuit. Placing **JP3** in the A-B position will enable the **soft stop** option, position B-C will disable the **soft stop** option. If the **soft stop** is enabled 24VDC and **GND** must be connected to the **soft stop** input for normal operation. Removing 24VDC from the **soft stop** input will turn off the output at a rate set by the **ramp** settings.

**REVERSE CMD OPTION**

Connecting 24VDC and **GND** across the **reverse CMD** input will cause the output to switch the current from one channel to the other at a rate set by the **ramp** circuit. This will allow a unipolar command signal to control the pump on both sides of center.

**WARNING:** Once the **reverse CMD** input has been energized loss of this signal will reverse the driver cards output signal.

**RAMP-AT-ZERO OPTION**

The **ramp-at-zero** is an output that indicates when the ramp circuit output is at zero. The **ramp-at-zero** output is 15VDC when ramp is at zero and **0VDC** when ramp is not at zero. One application for the **ramp-at-zero** function is to hold the integrator of the Jupiter options card, S20-11716, at zero when system command is zero.

**CLOSED-LOOP-CONTROL**

The driver card operating as a stand alone driver is used primarily for open-loop control. With the **Jupiter options card**, S20-11716, the driver card can be used for closed-loop speed control systems. The options card provides digital encoder and DC tachometer feedback, horsepower limiting and PI control of the feedback error.

**REMOTE OPERATION ONLY**

The front panel controls are factory enabled by JP1 at position A-B. Moving JP1 to position B-C disables the front panel controls for remote only operation.

**INSTALLATION & OPERATION GUIDELINES**

- For EMC compatibility, card must be installed in a NEMA 4 or equivalent enclosure; connect enclosure to earth ground.
- Shield (screen) all wires entering enclosure. Connect card end of shield to earth ground. Leave other end of shield open.
- Use Denison Hydraulics recommended power supply P/N 762-30036.
- Disconnect power before inserting or removing card.
- Use high resistance meter for all testpoint measurements,  $R_i > 100K$ .
- Maximum wire length between driver card and pump 9A control valve is 150 feet of 16 AWG, operating at minimum 22VDC supply voltage, 0.35A coil current and 80°C fluid temperature. When using 14 AWG distance can be increased to 240 feet.

**SET-UP PROCEDURE**

1. With the hydraulic system de-energized, connect the Jupiter 900 driver card according to the attached block diagram, then apply 24VDC to the driver card. The **power LED** should be illuminated and the **stop LED** should not be illuminated.
2. If the **power LED** is not lit, check the wiring and apply power again.
3. Connect a **DVM** (digital volt meter) to the IOUT test point and the **GND** test point on the front panel. Apply a positive 3% command signal to the appropriate input. Adjust the **Ia min** potentiometer until a value of +0.124VDC (+0.124A) is read on the **DVM**. Apply a negative 3% command signal to the appropriate input. Adjust the **Ib min** potentiometer until a value of -0.124VDC (-0.124A) is read on the **DVM**. This is a preliminary setting.
4. Apply a positive 100% command signal to the appropriate input, then adjust the **Ia max** potentiometer to give a value of +0.30VDC (+0.30A) on the **DVM**. Apply a negative 100% command signal to the appropriate input, then adjust the **Ib max** potentiometer to give a value of -0.30VDC (-0.30A) on the **DVM**. This is a preliminary setting.

Note: Before energizing hydraulic system make sure that system can handle high flow rate and that max pressure limit is set to prevent system damage.

5. Set the command signal to 0% and energize the hydraulic system. Slowly set command signal to +100% and then adjust **Ia MAX** potentiometer for desired max hydraulic flow. Slowly decrease command signal while observing DVM at IOUT testpoint. Set command slightly above the I<sub>MIN</sub> trip point and then adjust **Ia MIN** potentiometer until the minimum hydraulic output is at the desired level. Repeat the **IMAX** and **IMIN** adjustments for best hydraulic operating characteristic. Adjustments have slight interaction.
6. For bi-directional systems repeat step 5 above with a negative command signal and adjust **Ib MAX** and **Ib MIN** for best operating characteristics.

EUROCARD HOLDER  
701-00007-8

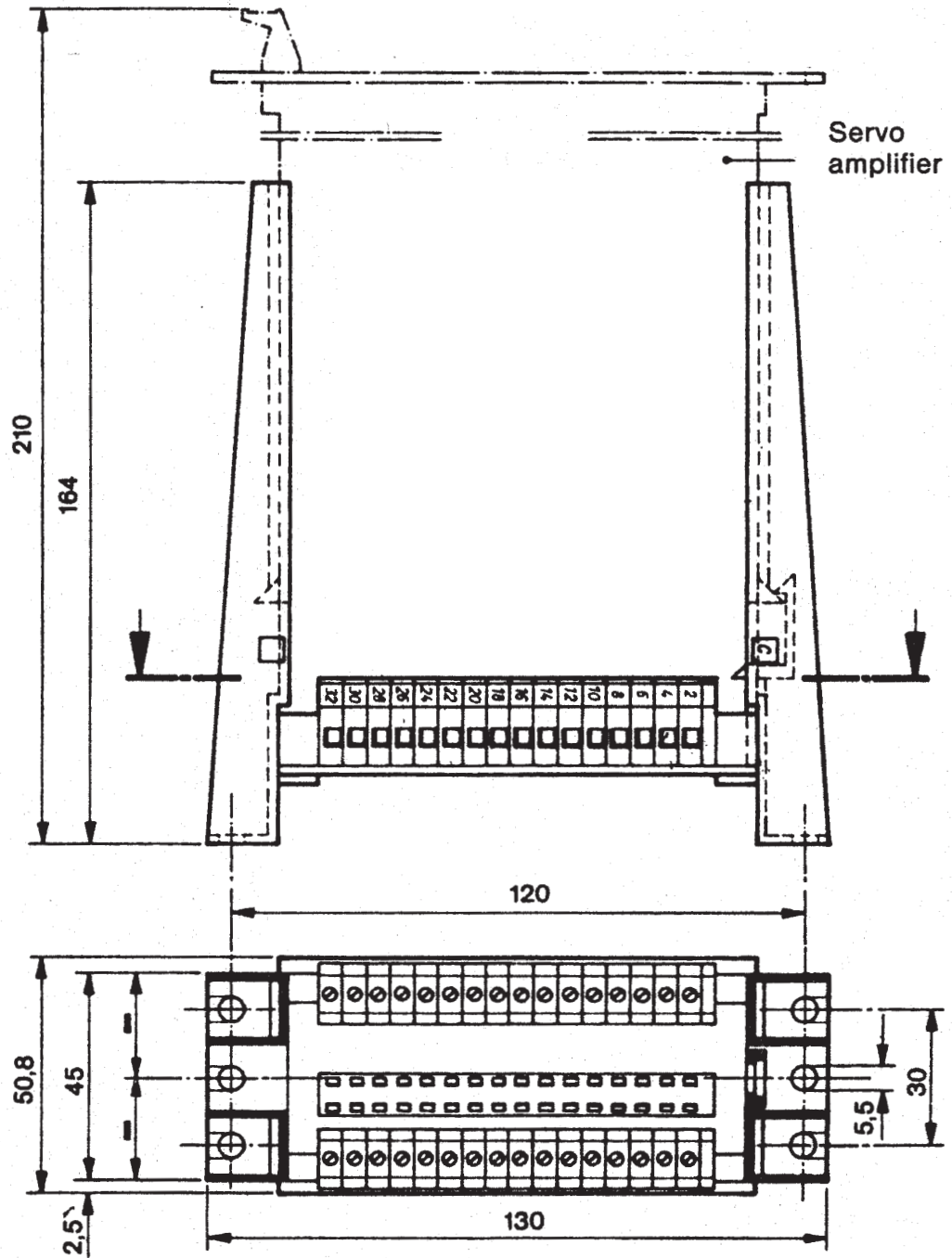

JUMPER & SWITCH LOCATIONS

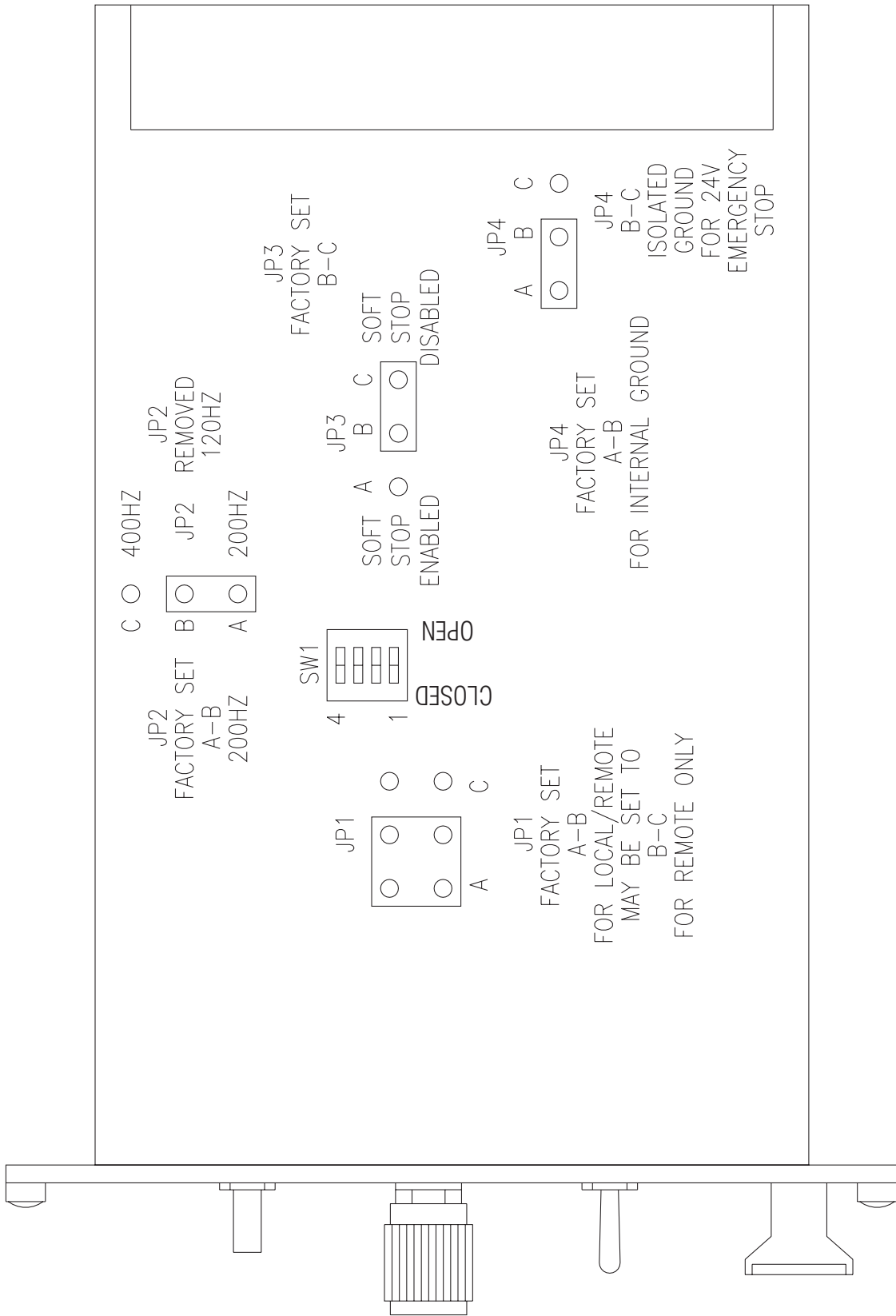

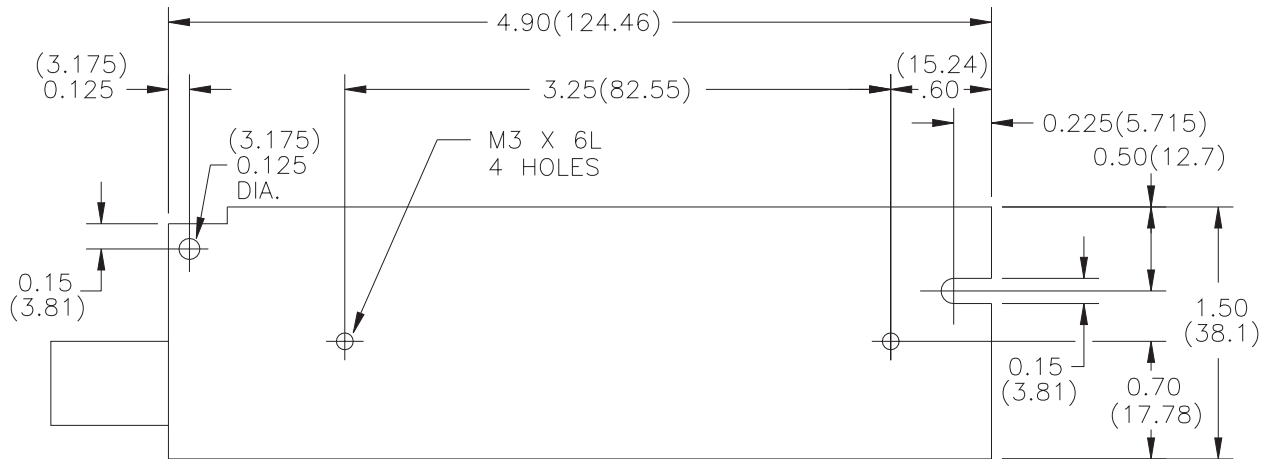

[mm]

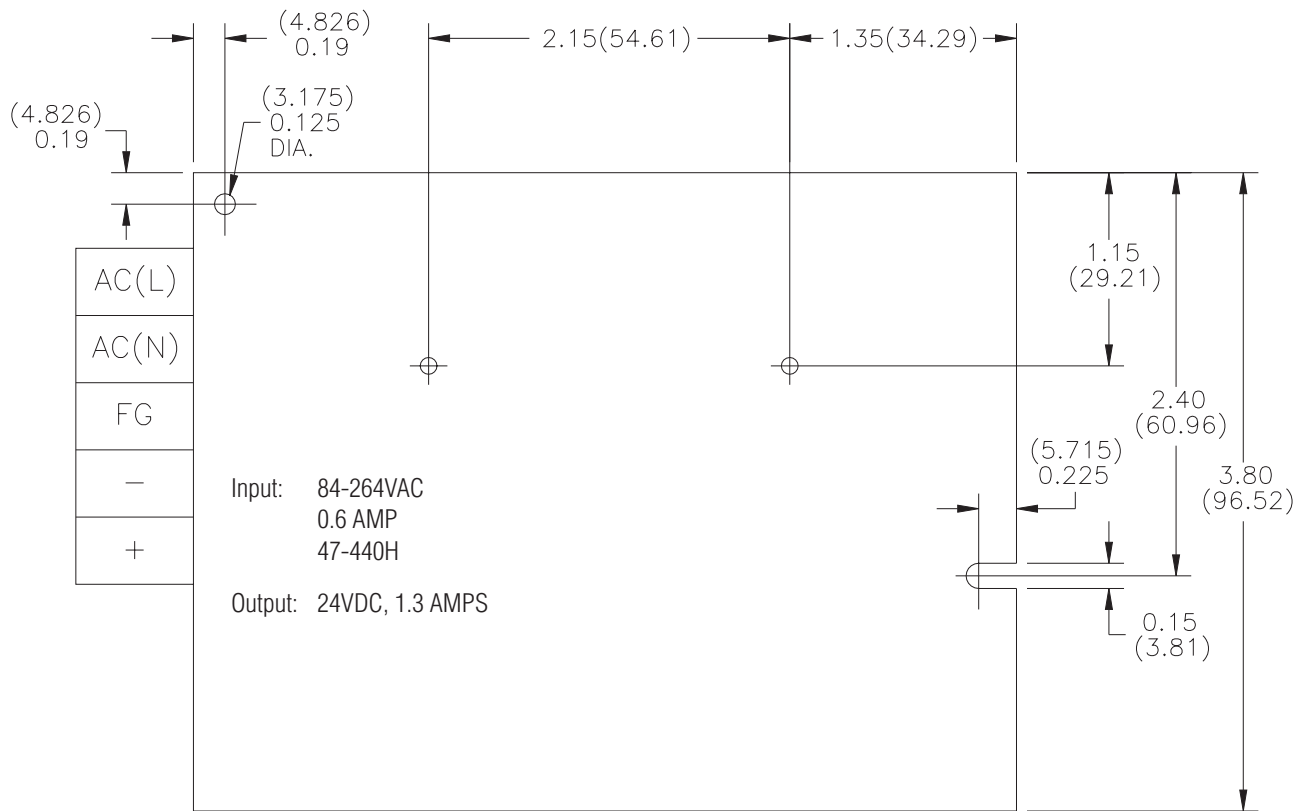

BOTTOM VIEW

762-30026 POWER SUPPLY MOUNTING HOLES  
DIMENSIONS IN INCHES [MILLIMETERS]

TOP VIEW DRIVER CARD

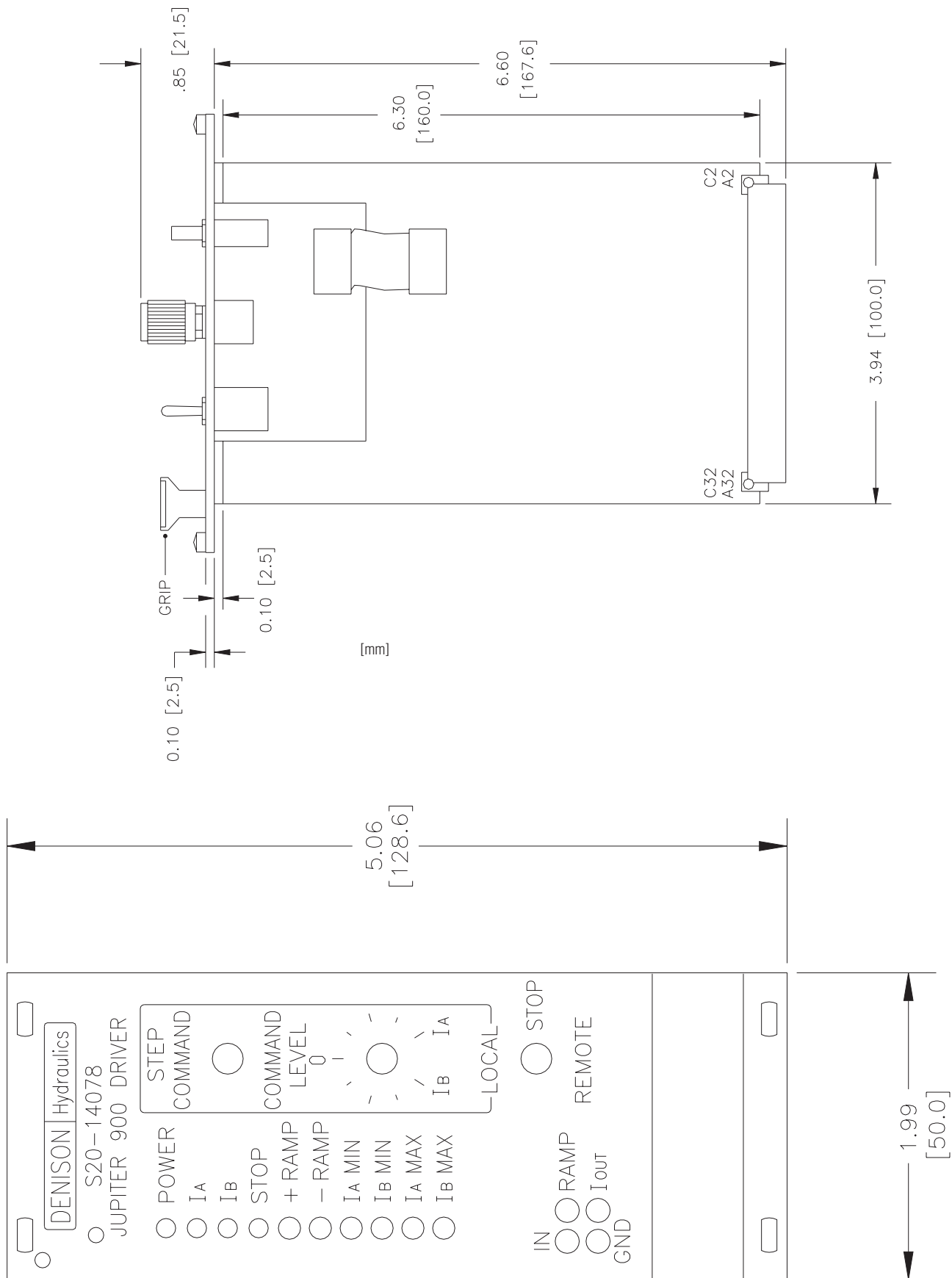

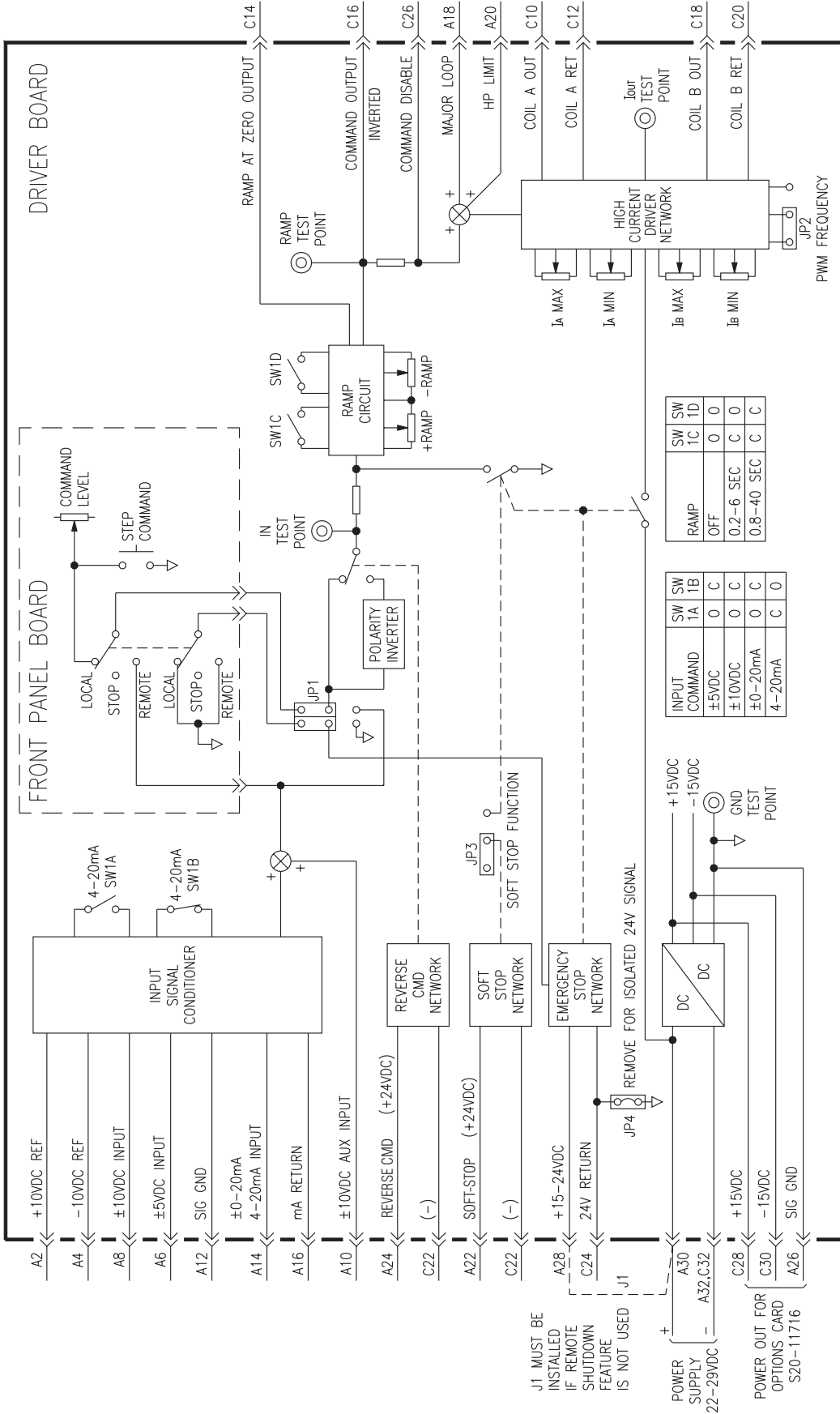

DIP SW1 MARKINGS

- 0 = OPEN
- C = CLOSED
- SW1A = 1
- B = 2
- C = 3
- D = 4

Block Diagram

Jupiter 900 Driver Eurocard Version S20-14078-0

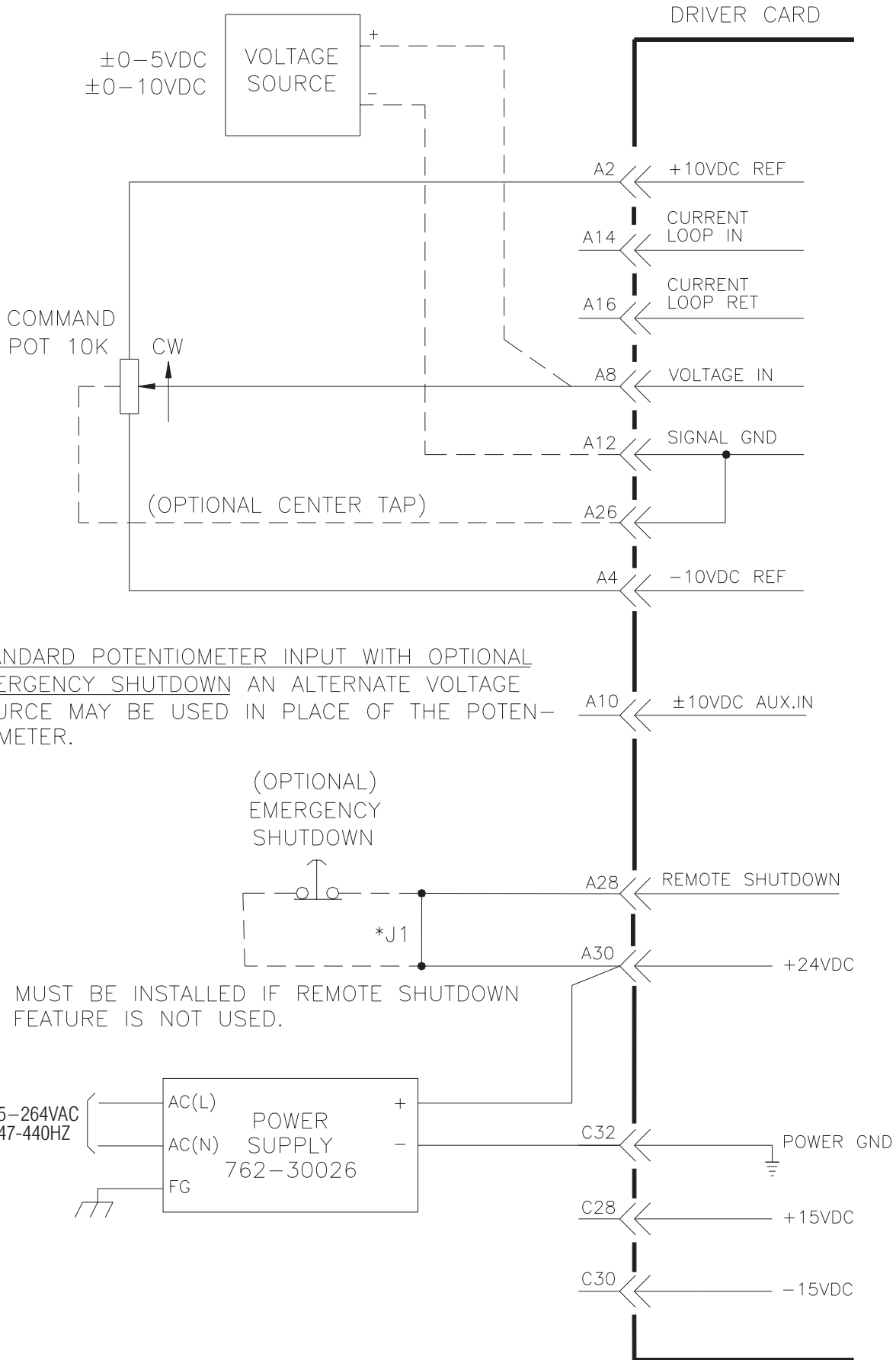

STANDARD POTENTIOMETER INPUT WITH OPTIONAL EMERGENCY SHUTDOWN AN ALTERNATE VOLTAGE SOURCE MAY BE USED IN PLACE OF THE POTENTIOMETER.

(OPTIONAL) EMERGENCY SHUTDOWN

\*J1 MUST BE INSTALLED IF REMOTE SHUTDOWN FEATURE IS NOT USED.

REMOTE VOLTAGE AND POTENTIOMETER INPUT CONNECTIONS



STANDARD CURRENT LOOP INPUT INTERLOCKED WITH AN AUXILIARY POTENTIOMETER INPUT AND OPTIONAL EMERGENCY SHUTDOWN.

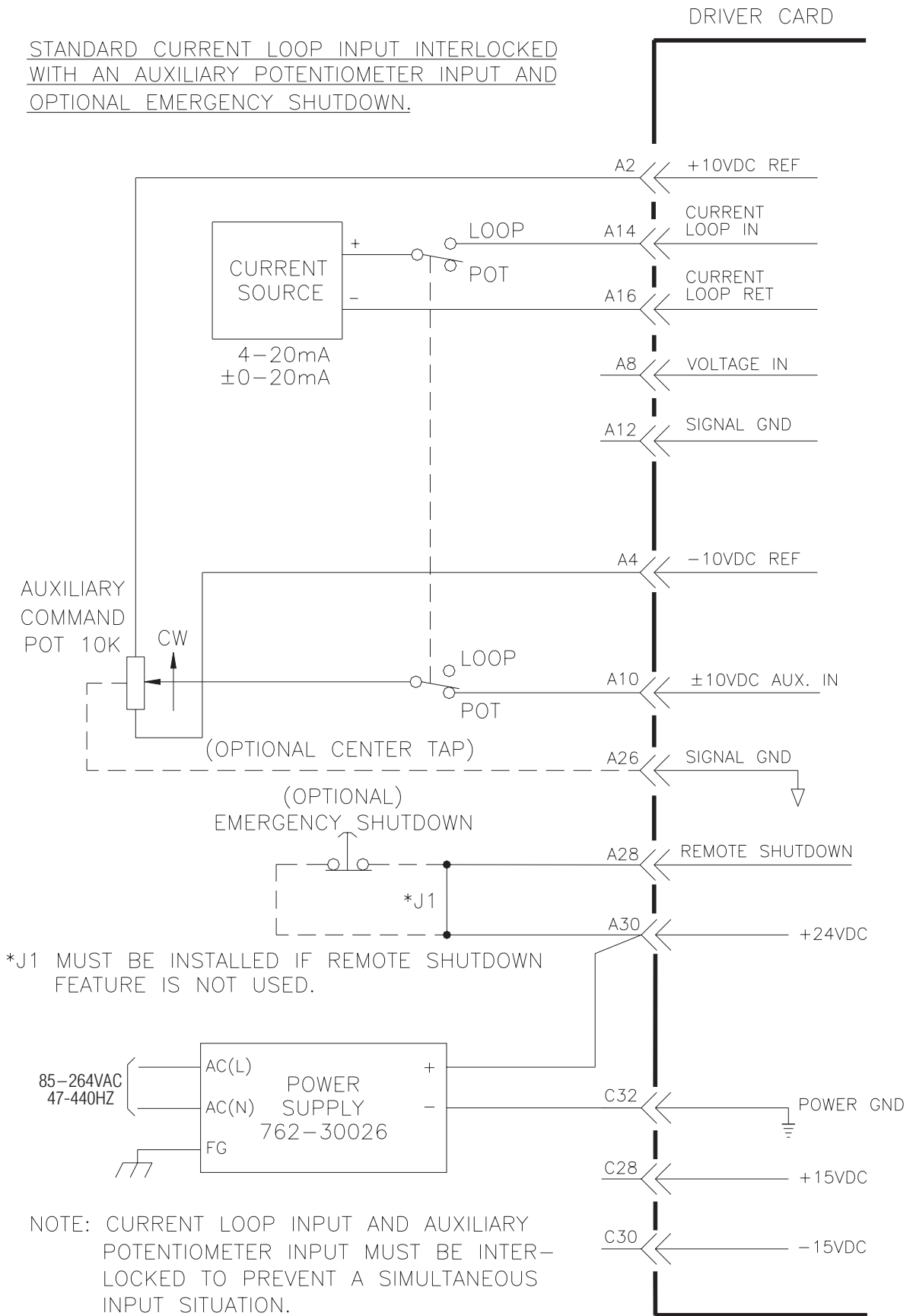

CURRENT LOOP INPUT CONNECTIONS

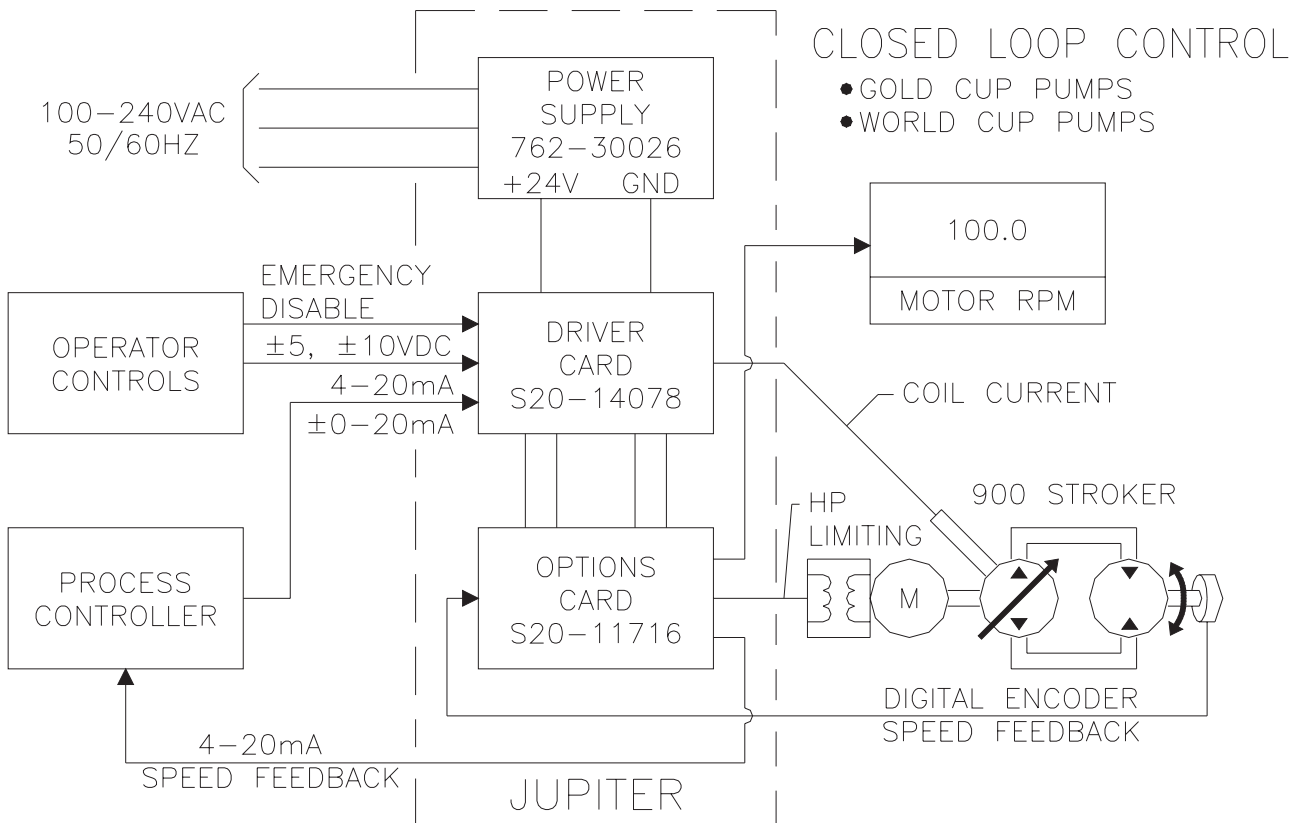
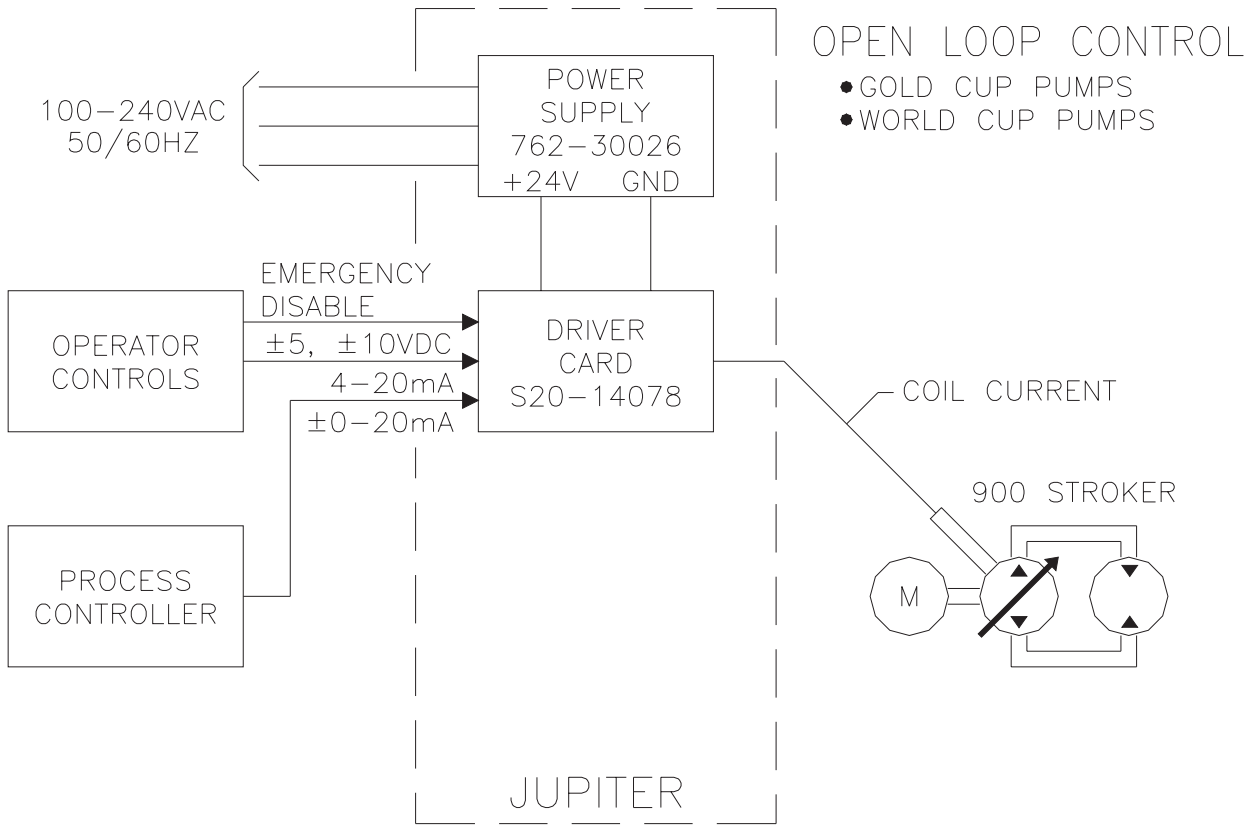

DIP SWITCH MARKINGS

0 = OPEN SW1A = 1  
 C = CLOSED (ON) B = 2  
 C = 3  
 D = 4

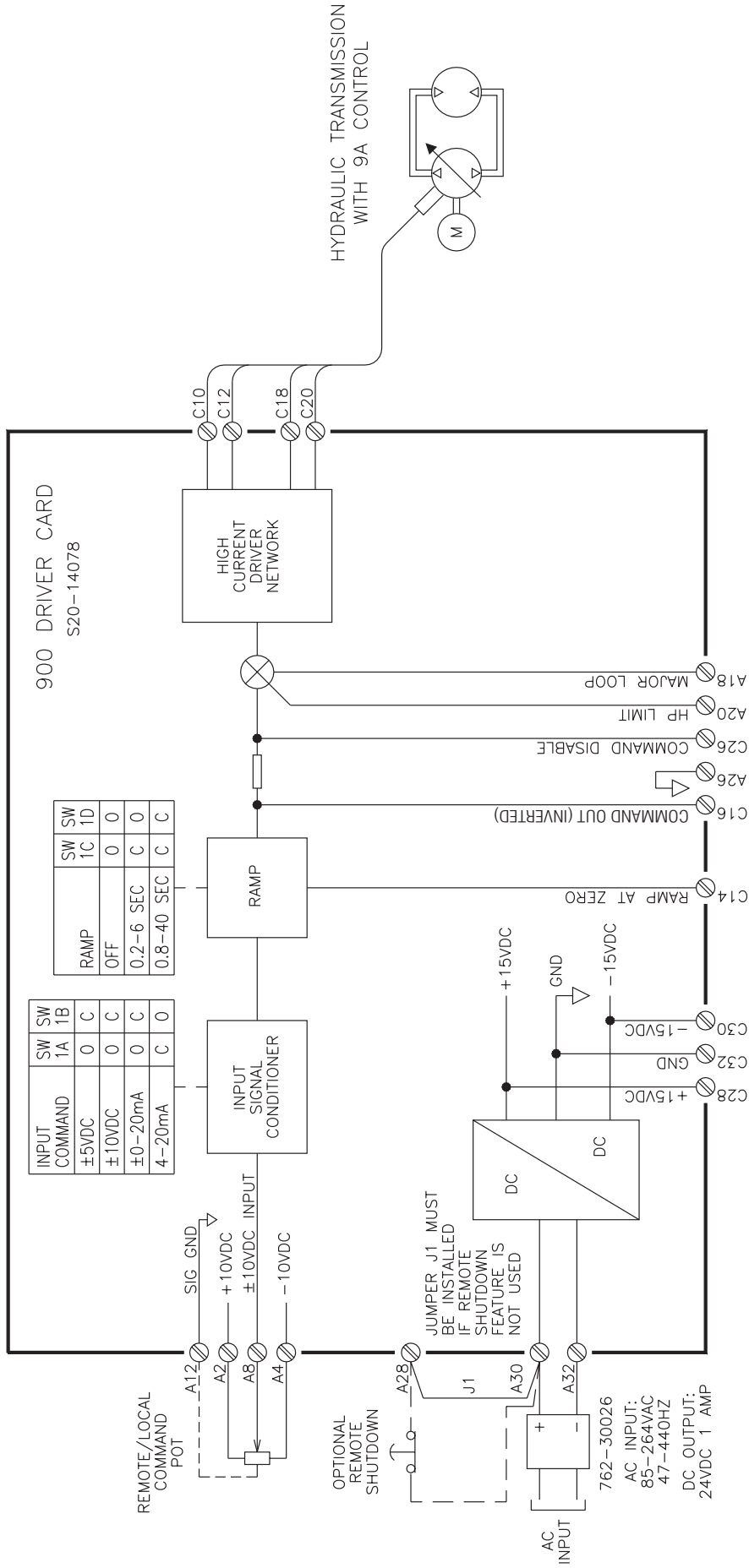

Block Diagram  
 Jupiter 900 Driver  
 Minimum Circuit for  
 Most Common Applications

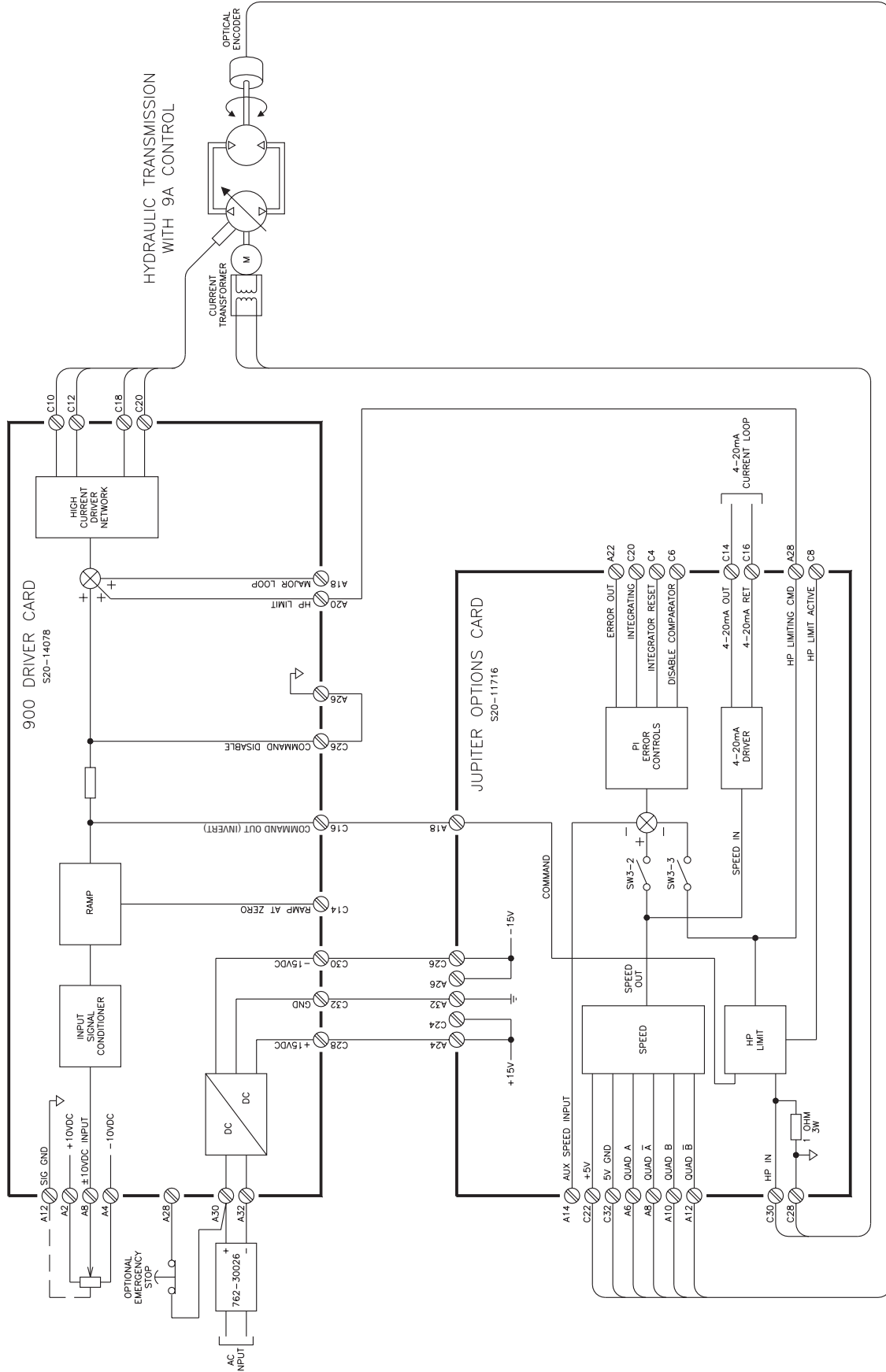

BLOCK DIAGRAM  
 JUPITER 900 DRIVER WITH OPTIONS CARD  
 OPEN-LOOP SPEED CONTROL WITH HORSEPOWER LIMITING

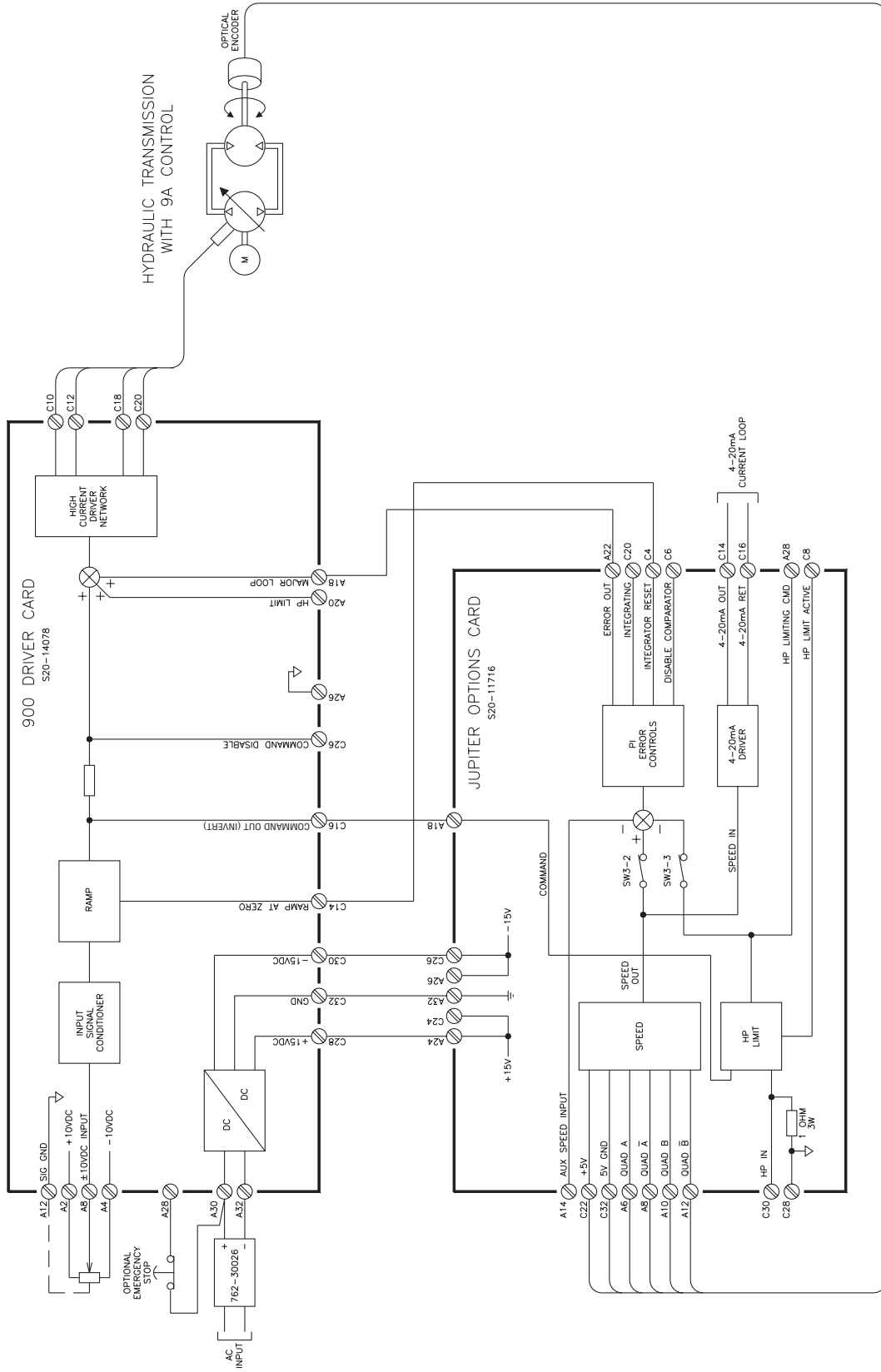

BLOCK DIAGRAM

JUPITER 900 DRIVER WITH OPTIONS CARD  
CLOSED-LOOP SPEED CONTROL WITH COMMAND FEEDFORWARDING

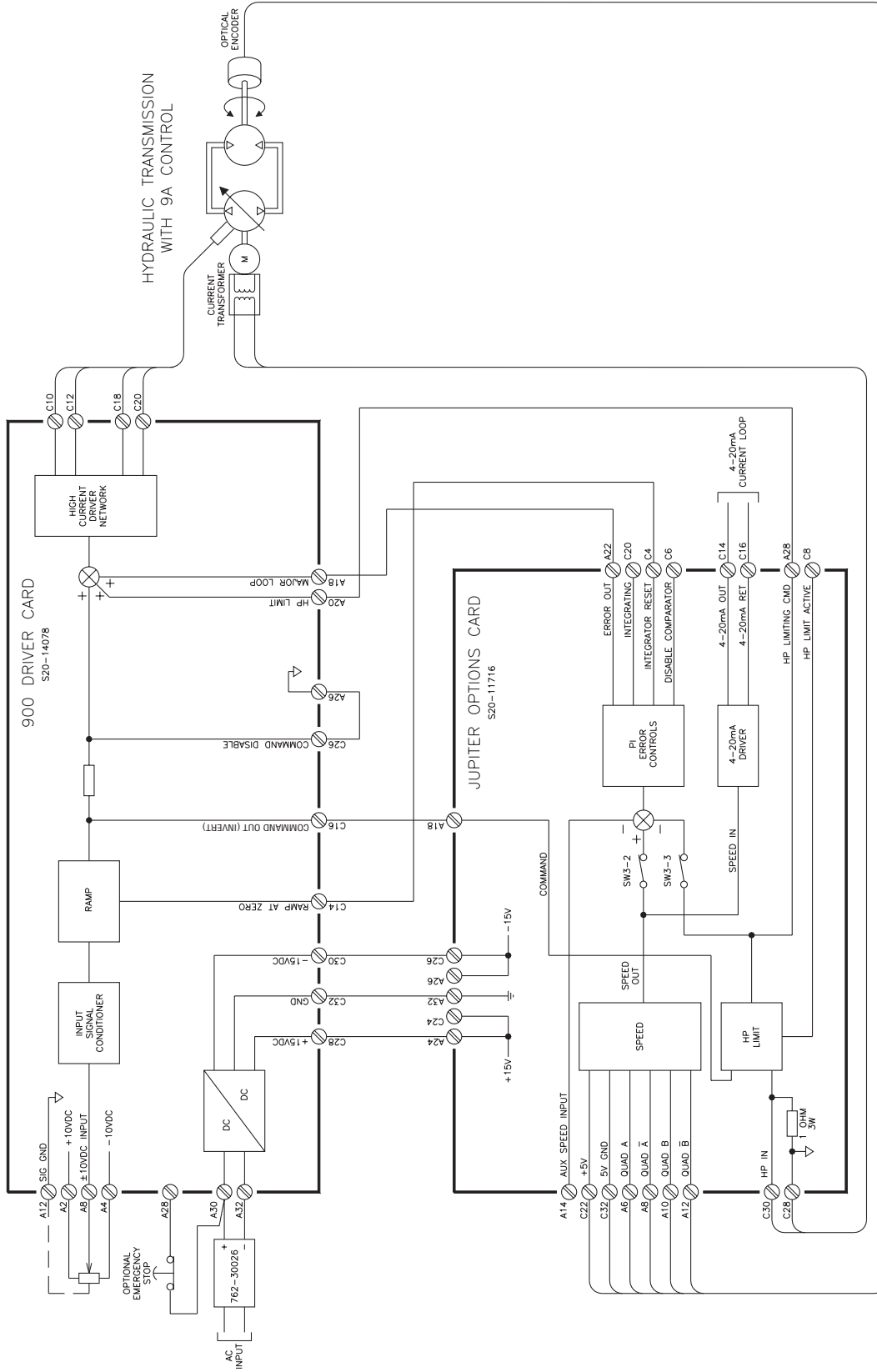

BLOCK DIAGRAM  
 JUPITER 900 DRIVER WITH OPTIONS CARD  
 CLOSED-LOOP SPEED CONTROL WITH  
 COMMAND FEEDFORWARDING AND HORSEPOWER LIMITING

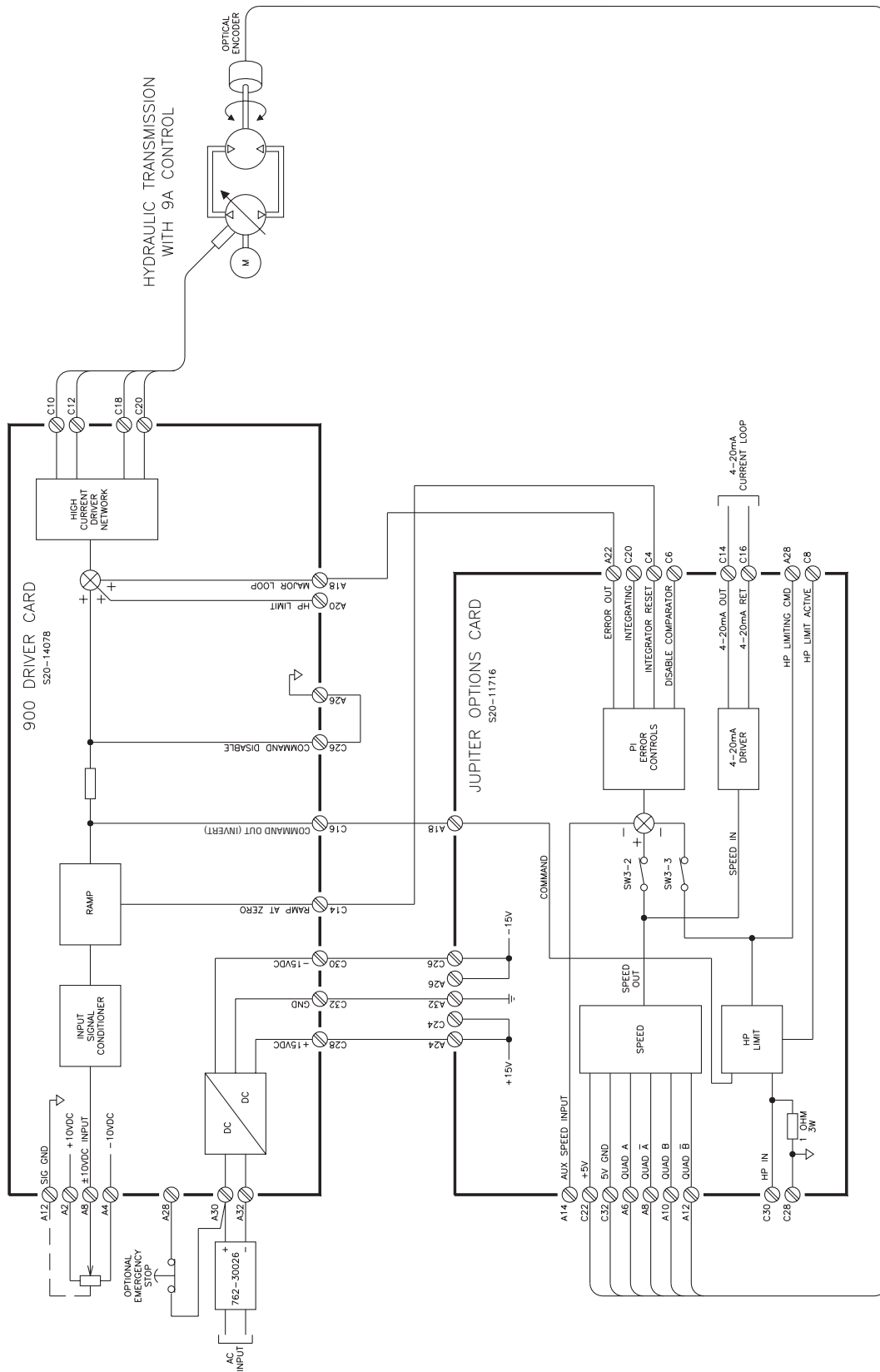

BLOCK DIAGRAM  
 JUPITER 900 DRIVER WITH OPTIONS CARD  
 CLOSED-LOOP SPEED CONTROL WITH PI

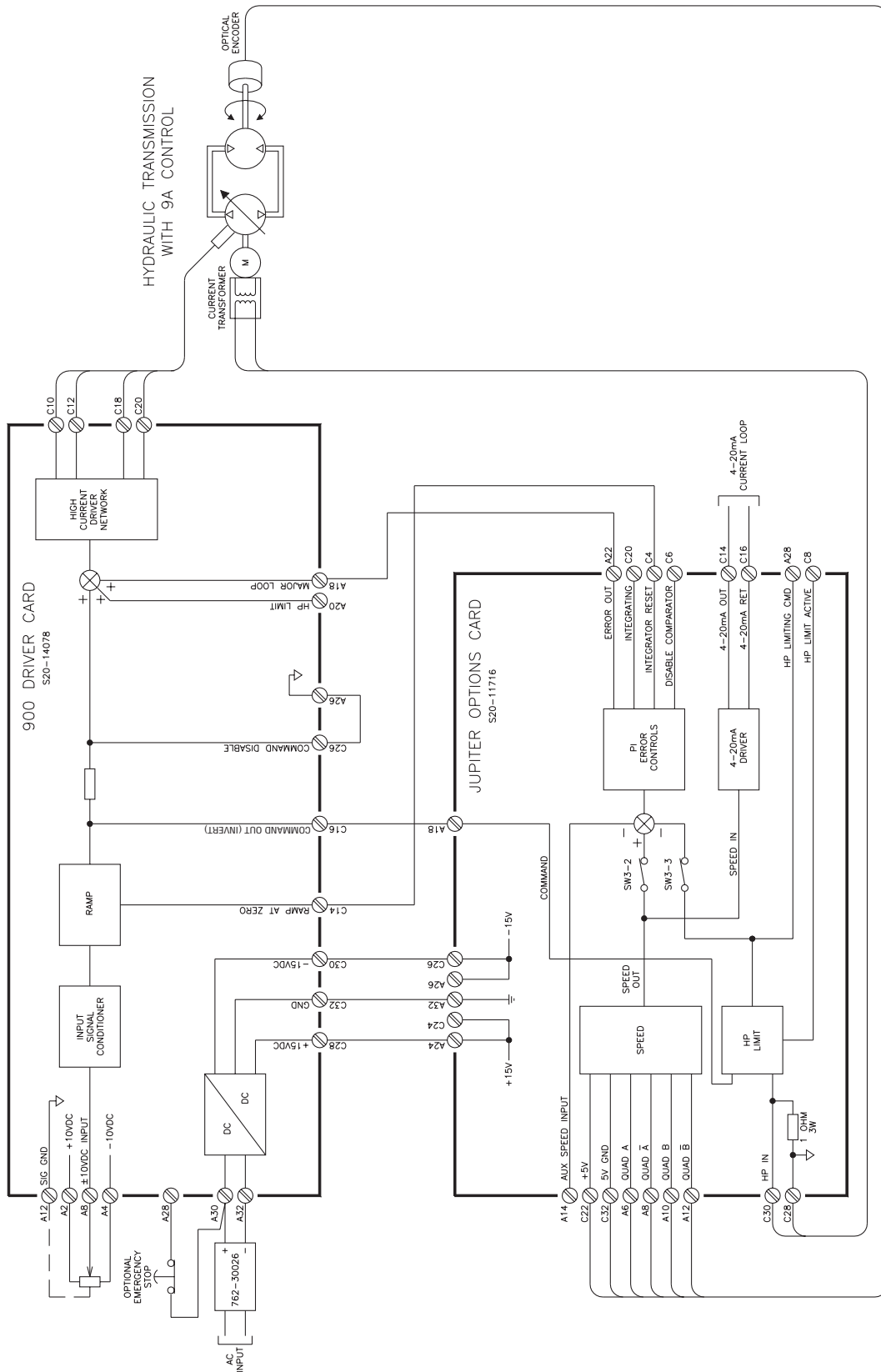

BLOCK DIAGRAM  
 JUPITER 900 DRIVER WITH OPTIONS CARD  
 CLOSED-LOOP SPEED CONTROL WITH  
 PI AND HORSEPOWER LIMITING









**International Distributors****In Europe:**

Cyprus  
 Eastern Europe  
 The Faroe Islands  
 Finland  
 Greece  
 Iceland  
 Norway  
 Portugal  
 Switzerland  
 Turkey

**In Africa:**

Algeria  
 Egypt  
 Ivory Coast  
 Morocco  
 Nigeria  
 South Africa  
 Togo  
 Tunisia

**In Middle East:**

Iran  
 Israel  
 Lebanon  
 Pakistan  
 Qatar  
 Saudi Arabia  
 Syria  
 United Arab Emirates

**In Far East:**

Indonesia  
 Korea  
 Malaysia  
 New Zealand  
 Philippines  
 Thailand

**Australia**

DENISON HYDRAULICS Pty. Ltd.  
 41-43 St. Hillers Road  
 P.O. Box 192  
 Auburn, N.S.W. 2144  
 Tel. (612) 9646 5200  
 Fax (612) 9643 1305  
**Other sales offices:**  
 Queensland  
 South Wantirna Victoria  
 Western Australia

**Austria**

DENISON HYDRAULIK GmbH  
 Zweigniederlassung Linz  
 Haidbachstraße 69  
 A-4061 Pasching  
 Tel. (43) 7229 4887  
 Fax (43) 7229 63092

**Benelux**

DENISON HYDRAULICS  
 BENELUX B. V.  
 Pascalstraat 100  
 3316 Dordrecht  
 Holland  
 Tel. (31) 786179 900  
 Fax (31) 786175 755

**Canada**

DENISON HYDRAULICS  
 CANADA Inc.  
 2320 Bristol Circle, Unit 1  
 Oakville, ON L6H 5S2  
 Tel. (905) 829 5800  
 Fax (905) 829 5805  
**Other sales offices:**  
 Montreal, QC  
 Calgary, AB

**China, P.R.**

DENISON HYDRAULICS Ltd.  
 3F, No. 1, Mao Jia Zhai, Bai Lian Jing  
 Pudong New Area  
 Shanghai 200126,  
 Tel. (86) 21 5886 8991  
 Fax (86) 21 5886 1978

**Denmark**

DENISON HYDRAULIK  
 DENMARK A/S  
 Industriekrogen 2  
 DK-2635 Ishøj  
 Tel. (45) 4371 15 00  
 Fax (45) 4371 15 16

**Finland**

DENISON HYDRAULICS  
 P.O. Box 36  
 FIN-08101 Lohja  
 Tel. (358) 208 33 045  
 Fax (358) 207 33 045

**France**

DENISON HYDRAULICS  
 FRANCE SA  
 14, route du Bois Blanc  
 BP 539  
 18105 Vierzon  
 Tel. (33) 2 48 53 01 20  
 Fax (33) 2 48 75 02 91  
**Other sales offices:**  
 Bordeaux  
 Lyon  
 Paris

**Germany**

DENISON HYDRAULIK GmbH  
 Herderstrasse 26  
 D-40721 Hilden  
 Tel. (49) 2103 940-6  
 Fax (49) 2103 940-880  
**Other sales offices:**  
 Dresden  
 Hanover  
 Stuttgart

**Great Britain**

DENISON HYDRAULICS U.K.  
 Ltd.  
 Kenmore Road  
 Wakefield 41, Industrial Estate  
 Wakefield, WF20XE  
 West Yorkshire  
 England  
 Tel. (44) 19 24 826 021  
 Fax (44) 19 24 826 146  
**Other sales offices:**  
 Burgess Hill

**Hong Kong, N. T.**

DENISON HYDRAULICS Ltd.  
 Unit 3, 25/F Wharf Cable Tower  
 9 Hoi Shing Road  
 Tsuen Wan  
 Tel. (852) 24988381  
 Fax (852) 24991522

**Italy**

DENISON HYDRAULICS S.r.l.  
 Viale Europa 68  
 20090 Cusago  
 Tel. (39) 2 90 33 01  
 Fax (39) 2 90 39 06 94

**Japan**

DENISON JAPAN Inc.  
 4-2-1 Tsujido-Shinmachi  
 Fujisawa 251,  
 Tel. (81) 466 35 3257  
 Fax (81) 466 35 2029  
**Other sales office:**  
 Osaka

**Mexico, Central America, South America and Caribbean**

**Countries Contact**  
 DENISON HYDRAULICS Inc.  
 6167 NW 181 Terrace Circle North  
 Miami, FL 33015, USA  
 Tel. (305) 362 2246  
 Fax (305) 362 6220

**Other European, Middle East and African Countries Contact**

DENISON HYDRAULICS  
 FRANCE SA  
 14, route du Bois Blanc  
 BP 539  
 18105 Vierzon Cedex  
 France  
 Tel. (33) 2 48 53 01 45  
 Fax (33) 2 48 53 01 46

**Singapore**

DENISON HYDRAULICS S.E.A.  
 Pte. Ltd.  
 No. 11 Lorong Tukang Dua  
 2261 Singapore  
 Tel. (65) 2687840  
 Fax (65) 2687847

**Spain**

DENISON HYDRAULICS, S.A.  
 Gomis, 1  
 08023 Barcelona  
 Tel. (34) 3418 46 87  
 Fax (34) 3211 65 07  
**Other sales offices:**  
 San Sebastian

**Sweden**

DENISON HYDRAULICS  
 SVENSKA AB  
 Sporregatan 13  
 213 77 - Malmö  
 Tel. (46) 40 21 04 40  
 Fax (46) 40 21 47 26  
**Other sales offices:**  
 Spånga

**Taiwan, R.O.C.**

DENISON HYDRAULICS Ltd.  
 6F-10, No. 79, Sec. 2, Roosevelt Road  
 Taipei,  
 Tel. (886) 2 3645101 / 3645102  
 Fax (886) 2 3639025

**USA**

DENISON HYDRAULICS Inc.  
 14249 Industrial Parkway  
 Marysville, OH 43040  
 Tel. 937 644 3915  
 Fax 937 642 3738  
 For nearest Distributor:  
 Call toll free 1 800 551 5956  
**Other sales offices:**  
 Fulton, CA  
 Mulberry, FL  
 Moline, IL  
 Rock Island, IL  
 Kentwood, MI  
 Portland, OR  
 Collierville, TN  
 Arlington, TX  
 Houston, TX

Your local DENISON representative

**DENISON** Hydraulics