

KEB COMBIBOX

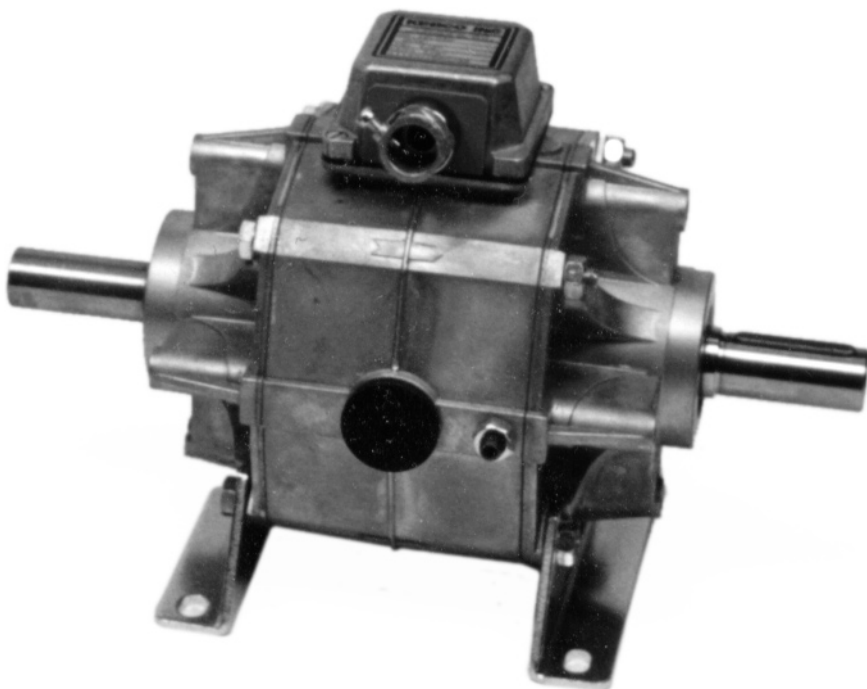

INSTRUCTION MANUAL

00.10.000-101U



12/2005

TABLE OF CONTENTS

DETERMINING UNIT TYPE.....	2
INSTALLATION & WIRING.....	3
PERMISSIBLE SHAFT LOAD.....	4
OPERATION & MAINTENANCE.....	4
ADJUSTING INSTRUCTIONS.....	5
REPLACEMENT & REPAIR PROCEDURE.....	6
ELECTRONIC CONTROLS & ACCESSORIES.....	6
EXPLODED VIEW XX.10.670*.....	7
EXPLODED VIEW OF XX.10.370*.....	8

*XX denotes Size

For further information please contact KEB AMERICA, Inc. at 1-952-224-1400.

DETERMINING UNIT TYPE

In order to properly mount and wire the KEB Combibox, it is necessary to identify the type of the unit. To do this, find the part number of the unit, which is located on top of the terminal box. It should be in the following format:

XX.YY.ZZZ (Example: 06.10.370)

YY indicates Type as follows:

06	Clutch/permanent magnet brake
09	Clutch only
10	Clutch/electric brake
16	Clutch/spring-set brake

The clutch rotor transmits the power from the input to the output by making secure frictional contact with the armature. The armature is fastened to the output shaft. The arrow on the Combibox housing always points from the input (clutch side) to the output (brake side). Mount the unit accordingly!

When direct DC voltage is supplied to the Combibox, the terminal strip shown in Figure 1 will be mounted in the conduit box.

Polarity in the clutch and brake is not relevant when wiring type 09, 10, and 16, but it is relevant when wiring the type 06 Combibox. The green wire with the red stripe is positive and the green wire with the blue stripe is negative.

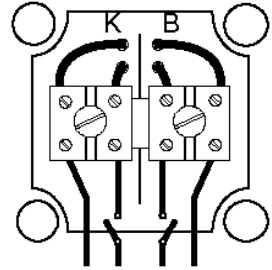

**K = Clutch
B = Brake**

When AC power is supplied to the Combibox, a rectifier will be used in place of the terminal strip. See Figures 2 and 3 for possible wiring configurations for a type 09 or 10 Combibox. See Figure 4 for the wiring configuration for a type 06 or 16 Combibox.

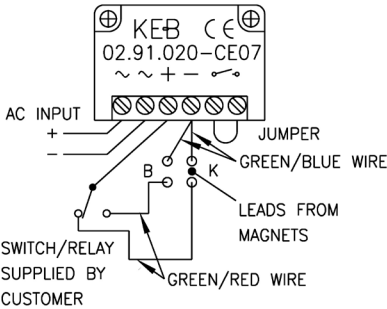

Figure 2

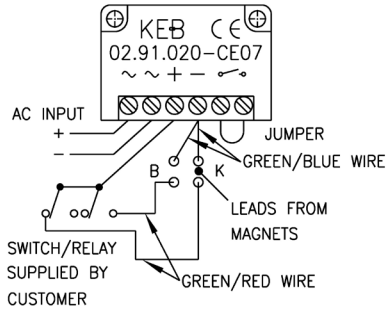

Figure 3

There are two basic rectifiers available for clutch/brake combination:

- 02.91.020-CE07 for 110VAC/ 95VDC, bridge rectifier
- 02.91.010-CE07 for 220VAC/ 95VDC, half wave rectifier.

Relays for switching should be rated at least 250VDC/10A

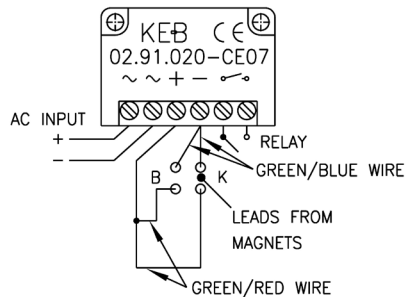
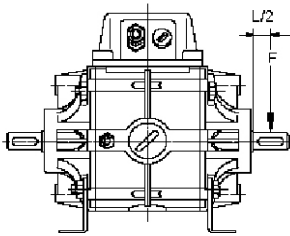
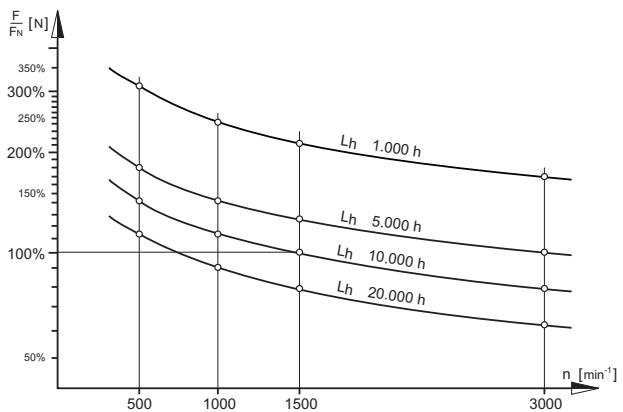

Figure 4

PERMISSIBLE SHAFT LOAD



Size	F_N (N)	$L/2$ (mm)
6	314	15
7	370	20
8	570	25
9	811	30
10	1469	30
11	2200	55



The value F_N refers to the load at the middle of the shaft, distance $L/2$. It is based on a service life of 10,000 h and a speed of 1500 rpm. For other speed and service life values, F_N can be calculated with the aid of the graph shown above. If additional axial forces occur, a recalculation of the bearing load should be performed by the factory.

Example:

$$L_h = 5000 \text{ h}, n = 1000 \text{ rpm}$$

$$F/F_N = 1.5 \text{ therefore } F = 1.5 \times F_N$$

OPERATION & MAINTENANCE

The KEB Combibox is shipped ready for installation with the air gap preadjusted to the nominal value. NEMA, or IEC mounting dimensions on the input and output ends allow for easy assembly to motors and gearboxes. **DO NOT FORCE FIT** when mounting. An antiseize lubricant should be used on the shaft when mounting the Combibox. To avoid contamination of the friction surfaces, do not use excessive amounts of lubricant.

Proper sizing of the Combibox in accordance with the application will minimize wear and reduce maintenance. The air gap should be readjusted according to the instructions when it reaches three times its nominal

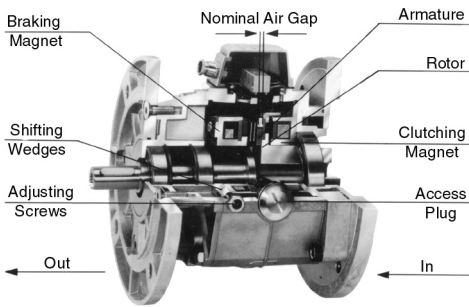

Size	Nominal Air Gap (Inches)
6	0.008
7	0.012
8	0.014
9	0.014
10	0.016
11	0.016

ADJUSTING INSTRUCTIONS

PLEASE NOTE: REFER TO PAGE 2. "DETERMINING UNIT TYPE." BEFORE PROCEEDING.

- **TYPES 09 AND 16 MUST BE RETURNED TO KEB AMERICA FOR ADJUSTMENT.**
1. For type 10, engage the clutch by supplying the proper DC voltage to the clutch magnet. For type 06, power is required to both clutch and brake simultaneously.
 2. Remove the access plugs from each side of the Combibox.
 3. Loosen the two lock nuts (See Figure 5).
 4. Insert the feeler gauge between the brake magnet and the armature. Tighten the adjusting screws (clockwise) until the nominal air gap is reached. The air gap should be equal on each side (See Figure 6).
 5. Tighten the lock nuts.
 6. Screw the plugs back into the access holes.

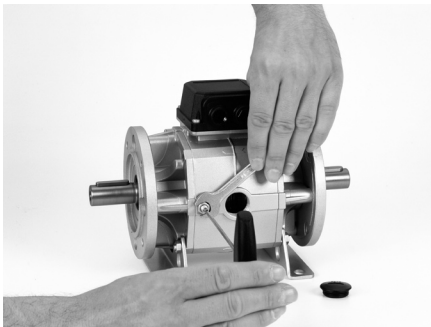

Figure 5



Figure 6

REPLACEMENT & REPAIR PROCEDURE

When the Combibox has reached maximum wear, the wear parts must be replaced. Wear parts include the brake magnet, the armature, and the clutch rotor. To order spare parts, provide the 11 digit part number, or the following information:

1. Size and type of unit
2. Magnet voltage
3. Input style of unit (solid or hollow shaft, and bore size)

In order to replace worn parts with new parts, refer to the next page and proceed as follows:

1. Open the terminal box and loosen all electrical connections to the clutch and the brake.
2. Disassemble the Combibox housing by unscrewing the four bolts.
3. Replace the worn clutch rotor with the new rotor. Avoid any contamination of the friction lining. The clutch rotor is always on the input side of the Combibox, the arrow on the housing points from the input to the output.
4. Replace the armature and the brake magnet with the new parts. Use LOCTITE when tightening all screws. **Clean friction surfaces with pure alcohol before installation.**
5. Wire the clutch and the brake terminals in the conduit box.
6. Assemble the Combibox and adjust the air gap as outlined above.

ELECTRONIC CONTROLS & ACCESSORIES

KEB Combित्रon 33.94 Rapid Switch

The combित्रon 33.94 provides a smooth 24VDC signal to the clutch/brake unit through activation by proximity switches, photocells, mechanical relays, etc. The 33.94 briefly overexcites the coils, which reduces switching times for a given load by approximately 2/3's. Extremely high cycle rates can be achieved while maintaining the absolute accuracy necessary for complex motion control applications.

Rectifiers

KEB rectifiers are the best in the industry and are varistor protected for maximum safety when switching inductive loads. Bridge and half-wave rectifiers are available for AC or DC side switching.

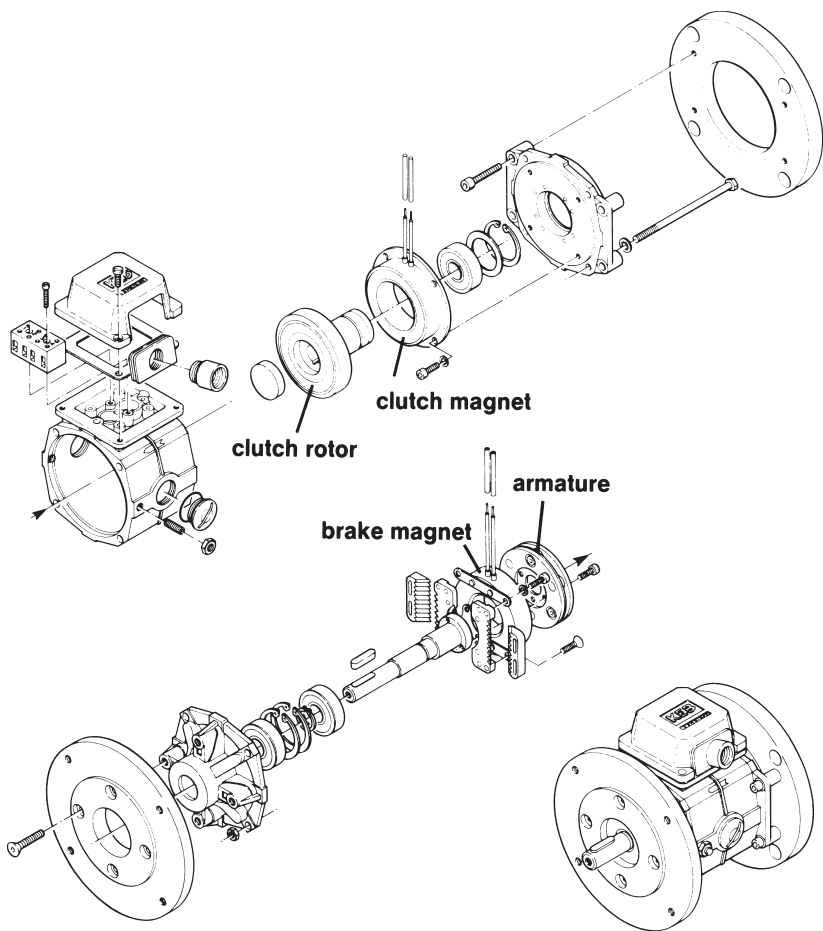

EXPLODED VIEW OF XX.10.370

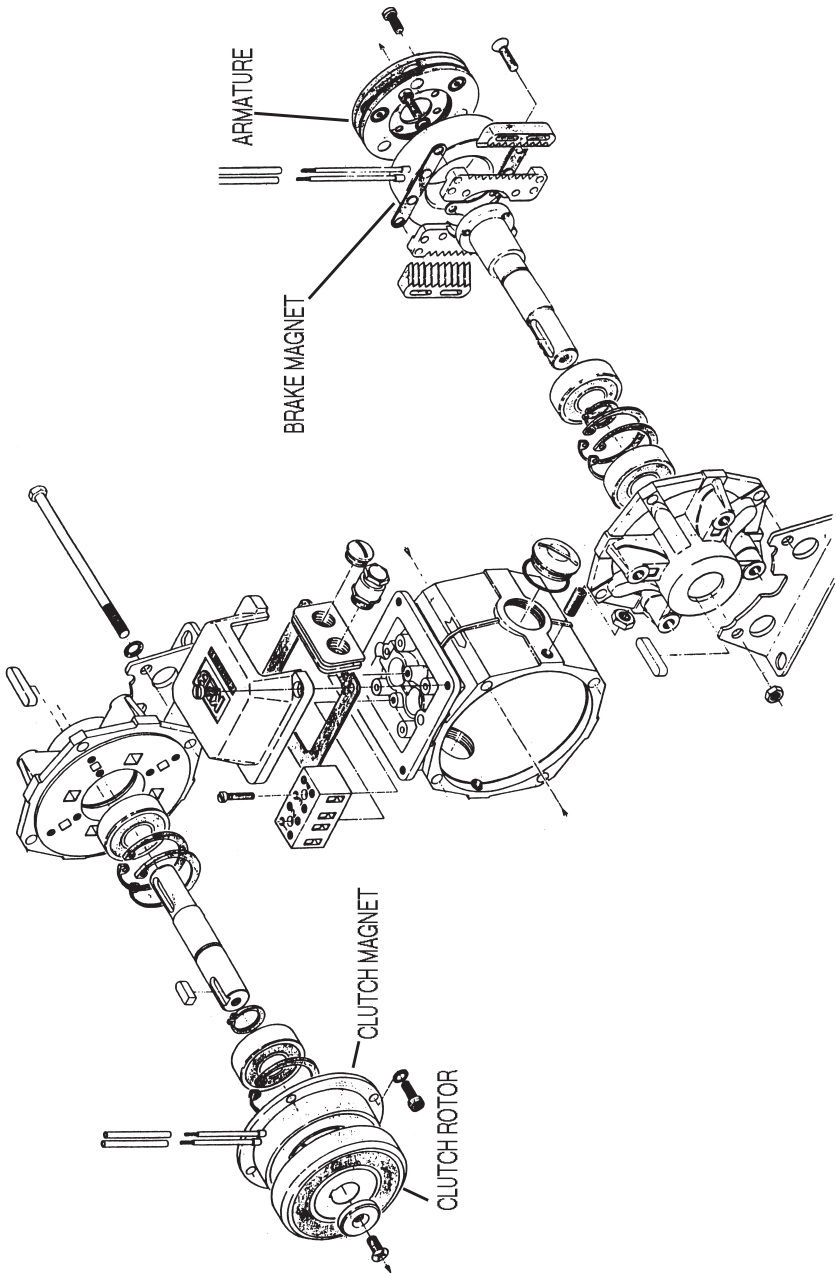

KEB AMERICA, Inc.
5100 Valley Industrial Boulevard South
Shakopee, MN 55379
Tel: 1-952-224-1400 • FAX: 1-952-224-1499
Internet: www.kebamerica.com
E-mail: info@kebamerica.com