

### A-5-3.3 LA Series

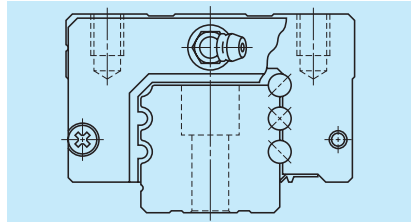
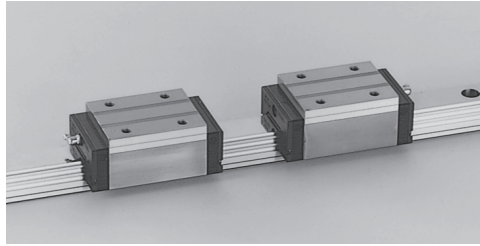

Fig. 1 LA Series

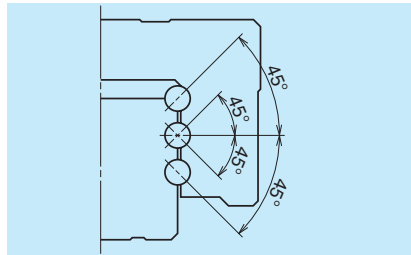

Fig. 2 Super rigidity design

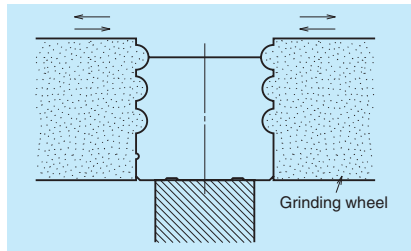

Fig. 3 Rail grinding

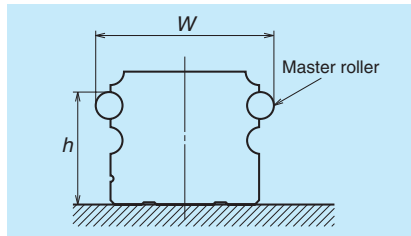

Fig. 4 Measuring groove accuracy

#### 1. Features

##### (1) High rigidity and high load carrying capacity

A set of three ball grooves is made on both sides of ball slide and a rail. This contributes to the increased rigidity and load carrying capacity. The top and bottom groove are formed in the circular arc with a closer radius of ball, which ensures great rigidity and load carrying capacity. With the Gothic arch center groove, rigidity and load carrying capacity are further increased.

##### (2) Moderate friction

A well-balanced combination of 2-point contacts at the top and bottom grooves and 4 points contact at the center groove provides moderate friction while ensuring rigidity by appropriate preload.

##### (3) Four-way equal load distribution

The contact angle of balls is set at 45 degrees in all grooves, thereby dispersing the load equally to four rows irrespective of load direction. This realizes equal rigidity and load carrying capacity in vertical and lateral directions and provides well-balanced design.

##### (4) Strong against shock load

Load from any direction, vertical and lateral, is received by four ball rows at all times. The number of the ball rows which receive the load is larger than in other linear guides, making this series stronger against shock load.

##### (5) High accuracy

As showing in Fig. 4, fixing the measuring rollers is easy thanks to the Gothic arch groove of the central ball groove. This benefits an accurate and measuring of ball groove for a highly precise and stable manufacturing.

##### (6) The dust protection design

The rail's cross section is designed as simple as possible, thereby improving the sealing efficiency combined with the enhanced sealing function. In addition, optional inner seals are available.

#### 2. Ball slide shape

Ball slide Model	Shape/installation method	Type (Upper row, Rating: Lower row, Ball slide length)	
		High-load type	Super-high-load type
		Standard	Long
AN BN		AN 	BN 
AL BL		AL 	BL 
EL GL		EL 	GL 
FL HL		FL 	HL 

#### 3. Accuracy and preload

##### (1) Running parallelism of ball slide

Table 1

Unit:  $\mu\text{m}$

Accuracy grade		Preloaded assembly (not random matching)			
		Ultra precision P3	Super precision P4	High precision P5	Precision grade P6
Rail length(mm)	over				
	or less				
	– 50	2	2	2	4
	50 – 80	2	2	3	4
	80 – 125	2	2	3	4
	125 – 200	2	2	3.5	5
	200 – 250	2	2.5	4.5	6
	250 – 315	2	2.5	5	6.5
	315 – 400	2	3	5.5	7
	400 – 500	2	3	6	7.5
	500 – 630	2	3.5	6.5	8.5
	630 – 800	2	4	7	9.5
	800 – 1 000	2.5	4.5	7.5	10
	1 000 – 1 250	3	5	8.5	12
	1 250 – 1 600	3.5	5.5	9.5	13
	1 600 – 2 000	4	6.5	11	14
	2 000 – 2 500	4.5	7.5	12	16
	2 500 – 3 150	5.5	8.5	13	18
	3 150 – 4 000	6	9.5	14	19

**(2) Accuracy standard**

The LA Series has four accuracy grades: Ultra precision P3, Super precision P4, High precision P5, and Precision grade P6.

**Table 2** Unit:  $\mu\text{m}$

Accuracy grade	Ultra precision P3	Super precision P4	High precision P5	Precision grade P6
Mounting height $H$ Variation of $H$ (All ball slides on a set of rails)	$\pm 8$ 3	$\pm 10$ 5	$\pm 20$ 7	$\pm 40$ 15
Mounting width $W_2$ or $W_3$ Variation of $W_2$ or $W_3$ (All ball slides on reference rail)	$\pm 10$ 3	$\pm 15$ 7	$\pm 25$ 10	$\pm 50$ 20
Running parallelism of surface C to surface A Running parallelism of surface D to surface B	Shown in <b>Table 1</b> and <b>Fig. 5</b>			

**(3) Assembled accuracy**

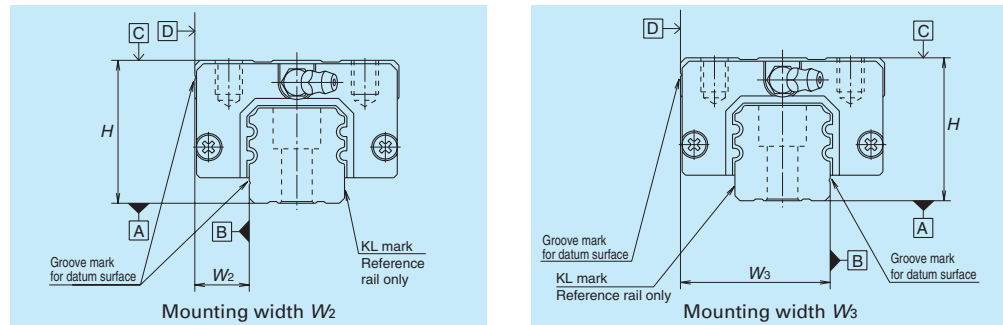

**Fig. 5**

**4. Preload and rigidity**

**Table 3** shows preload and rigidity of LA Series.

The LA Series has two types of preload specification: Medium preload Z3 and Heavy preload Z4.

**Table 3**

	Model No.	Preload (N)		Rigidity (N/ $\mu\text{m}$ )	
		Medium preload Z3	Heavy preload Z4	Medium preload Z3	Heavy preload Z4
High-load type	LA25 AL, AN, EL, FL	1 670	2 110	475	550
	LA30 AL, AN, EL, FL	2 450	3 150	705	835
	LA35 AL, AN, EL, FL	3 450	4 300	825	970
	LA45 AL, AN, EL, FL	5 050	6 350	1 100	1 240
	LA55 AL, AN, EL, FL	8 100	10 200	1 400	1 540
Super-high-load type	LA65 AN, EL, FL	13 800	18 800	1 730	2 030
	LA25 BL, BN, GL, HL	2 260	2 840	700	820
	LA30 BL, BN, GL, HL	3 250	4 050	1 000	1 180
	LA35 BL, BN, GL, HL	4 450	5 650	1 200	1 400
	LA45 BL, BN, GL, HL	6 150	7 750	1 450	1 640
	LA55 BL, BN, GL, HL	9 550	12 100	1 840	2 020
	LA65 BN, GL, HL	18 000	24 400	2 450	2 840

**4. Maximum rail length**

**Table 4** shows the limitations of rail length. However, the limitations vary by accuracy grades.

**Table 4** Length limitations of rails Unit: mm

Series	Size	25	30	35	45	55	65
LA		3 960	4 000	4 000	3 990	3 960	3 900

Note: Rails can be butted if user requirement exceeds the rail length shown in the table. Please consult NSK.

**5. Installation**

**(1) Permissible values of mounting error**

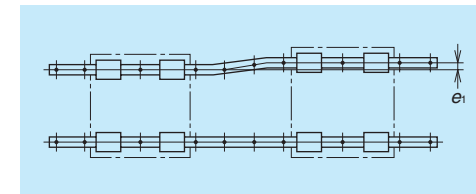

**Fig. 6**

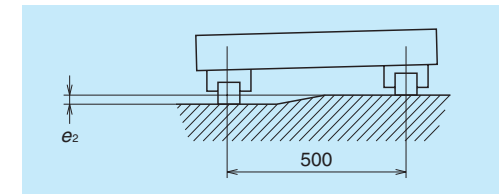

**Fig. 7**

**Table 5**

Unit:  $\mu\text{m}$

Value	Preload	Model No.					
		LA25	LA30	LA35	LA45	LA55	LA65
Permissible values of parallelism in two rails $e_1$	Z3	15	17	20	25	30	40
	Z4	13	15	17	20	25	30
Permissible values of parallelism (height) in two rails $e_2$	Z3, Z4	185 $\mu\text{m}/500\text{ mm}$					

**(2) Shoulder height of the mounting surface and corner radius r**

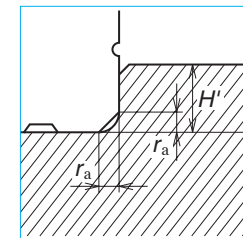

**Fig. 8** Shoulder for the rail datum surface

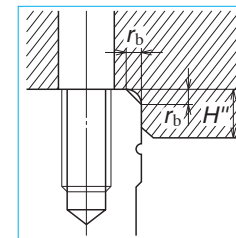

**Fig. 9** Shoulder for the ball slide datum surface

**Table 6**

Unit: mm

Model No.	Corner radius (maximum)		Shoulder height	
	$r_a$	$r_b$	$H'$	$H''$
LA25	0.5	0.5	5	5
LA30	0.5	0.5	6	6
LA35	0.5	0.5	6	6
LA45	0.7	0.7	8	8
LA55	0.7	0.7	10	10
LA65	1	1	11	11

## 6. Lubrication components

Refer to pages A38 and D13 for the lubrication of linear guides.

### (1) Types of lubrication accessories

Fig. 10 and Table 7 show grease fittings and tube fittings.

### (2) Mounting position of lubrication accessories

- The standard position of grease fittings is the end face of ball slide. We mount them on a side of end cap for an option. (Fig. 11).
- Please consult NSK for installation of grease or tube fittings to the ball slide body or side of end cap.
- When using a piping unit with thread of M6 × 1, you require a connector to connect to a grease fitting mounting hole with M6 × 0.75. The connector is available from NSK.

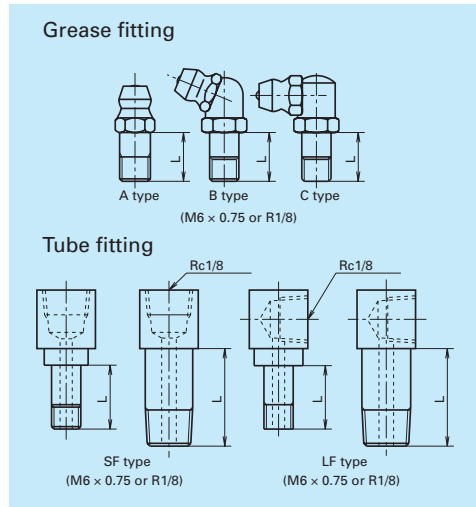

Fig. 10 Grease fitting and tube fitting

**Table 7** Unit: mm

Model No.	Dust-proof specification	Dimension L		
		Grease fitting	Tube fitting	
			SF type	LF type
LA25	Standard	5	5	5
	With NSK K1	14	12	12
	Double seal	10	9	9
LA30	Protector	10	9	9
	Standard	5	6	6
	With NSK K1	14	12	13
LA35	Double seal	12	10	11
	Protector	12	11	11
	Standard	5	6	6
LA45	With NSK K1	14	12	13
	Double seal	12	10	11
	Protector	12	11	11
LA55	Standard	8	13.5	17
	With NSK K1	18	22	21.5
	Double seal	14	18	17
LA65	Protector	14	16	17
	Standard	8	13.5	17
	With NSK K1	22	24	25.5
		16	20	19
		16	16	17

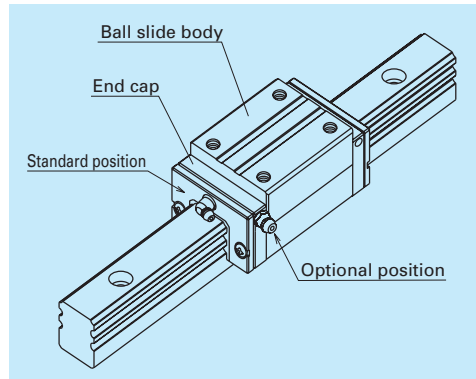

Fig. 11 Mounting position of lubrication accessories

## 7. Dust-proof components

### (1) Standard Specification

The LA Series can be readily used as they have a dust protection means for normal conditions. As the standard equipment, the ball slides have an end seal on both ends, and bottom seals at the bottom.

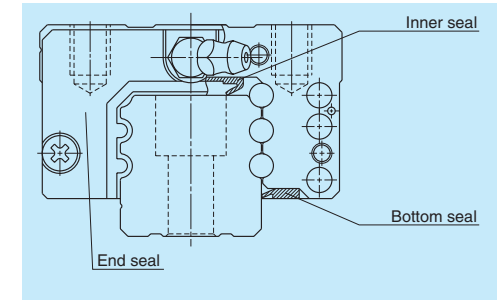

Fig. 12

**Table 8 Seal friction per ball slide (maximum value)** Unit: N

Series	Size	25	30	35	45	55	65
LA		11	11	12	17	17	23

### (2) NSK K1™ lubrication unit

Table 9 shows the dimension of linear guides equipped with the NSK K1 lubrication unit.

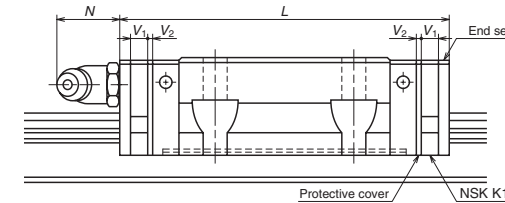

**Table 9** Unit: mm

Model No.	Ball slide length	Ball slide model	Standard ball slide length	Ball slide length installed with two NSK K1 L	Per NSK K1 thickness V <sub>1</sub>	Protective cover thickness V <sub>2</sub>	Protruding area of the grease fitting N
LA25	Standard	AL, AN, EL, FL	79.8	91.8	5.0	1.0	(14)
	Long	BL, BN, GL, HL	107.8	119.8			
LA30	Standard	AL, AN, EL, FL	100.2	113.2	5.5	1.0	(14)
	Long	BL, BN, GL, HL	126.2	139.2			
LA35	Standard	AL, AN, EL, FL	110.6	123.6	5.5	1.0	(14)
	Long	BL, BN, GL, HL	144.6	157.6			
LA45	Standard	AL, AN, EL, FL	141.4	156.4	6.5	1.0	(15)
	Long	BL, BN, GL, HL	173.4	188.4			
LA55	Standard	AL, AN, EL, FL	165.4	180.4	6.5	1.0	(15)
	Long	BL, BN, GL, HL	203.4	218.4			
LA65	Standard	AN, EL, FL	196.2	214.2	8.0	1.0	(16)
	Long	BN, GL, HL	256.2	274.2			

Note: Ball slide length equipped with NSK K1 = (Standard ball slide length) + (Thickness of NSK K1, V<sub>1</sub> × Number of NSK K1) + (Thickness of the protective cover V<sub>2</sub> × 2)

### (3) Double seal and protector

For the LA Series, a double seal and a protector can be installed only before shipping from the factory. Please consult with NSK when the double seal and the protectors are required.

**Table 10** shows the increased thickness of  $V_3$  and  $V_4$  when end seals and protectors are installed (**Fig. 15**).

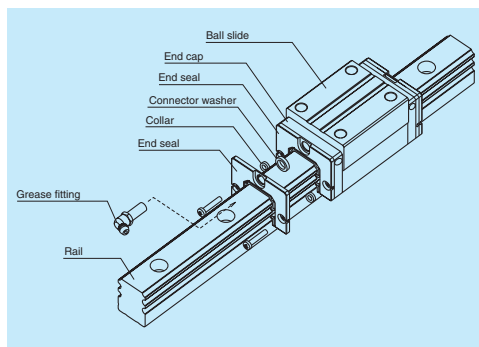

**Fig. 13 Double seal**

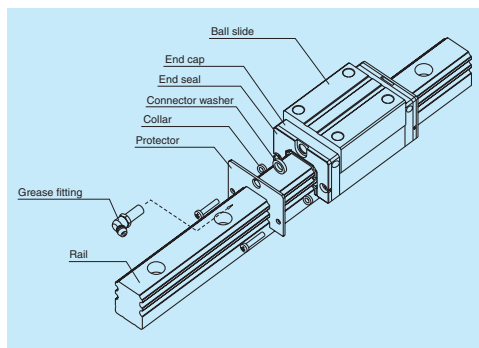

**Fig. 14 Protector**

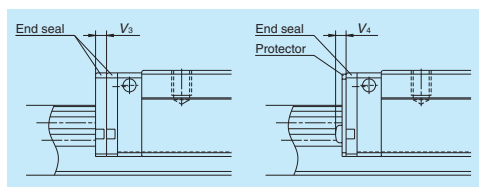

**Fig. 15**

**Table 10**

Unit: mm

Model No.	Thickness of end seal: $V_3$	Thickness of protector: $V_4$
LA25	3.2	3.6
LA30	4.4	4.2
LA35	4.4	4.2
LA45	5.5	4.9
LA55	5.5	4.9
LA65	6.5	5.5

### (4) Cap to plug the rail mounting bolt hole

**Table 11 Caps to plug rail bolt hole**

Model No.	Bolt to secure rail	Cap reference No.	Quantity /case
LA25	M6	LG-CAP/M6	20
LA30, LA35	M8	LG-CAP/M8	20
LA45	M12	LG-CAP/M12	20
LA55	M14	LG-CAP/M14	20
LA65	M16	LG-CAP/M16	20

### (5) Bellows

Make tap holes to the rail end face to fix the bellows mounting plate.

NSK processes tap holes to the rail end face when ordered with a linear guide.

### Dimension tables of bellows LA Series

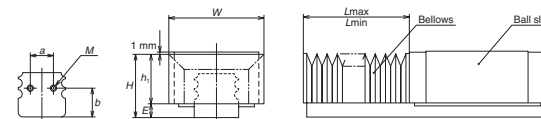

**Fig. 16 Dimensions of bellows**

#### Bellows reference number

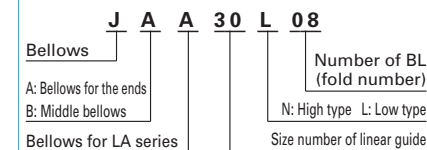

**Table 12 Dimensions of bellows**

Unit: mm

Model No.	H	$h_1$	E	W	P	a	b	Length of BL	Tap (M) × depth
JAA25L	35	29.5	5.5	55	12	12	13.8	17	M3 × 5
JAA25N	39	33.5	5.5	61	15	12	13.8	17	M3 × 5
JAA30L	41	33.5	7.5	60	12	14	17.5	17	M4 × 6
JAA30N	44	36.5	7.5	66	15	14	17.5	17	M4 × 6
JAA35L	47	39.5	7.5	72	15	15	18.8	17	M4 × 6
JAA35N	54	46.5	7.5	82	20	15	18.8	17	M4 × 6
JAA45L	59	49	10	93	20	25	22.5	17	M5 × 8
JAA45N	69	59	10	113	30	25	22.5	17	M5 × 8
JAA55L	69	57	12	101	20	35	27.1	17	M5 × 8
JAA55N	79	67	12	121	30	35	27.1	17	M5 × 8
JAA65N	89	75	14	131	30	40	33.3	17	M6 × 12

**Table 13 Numbers of folds (BL) and length of bellows**

Unit: mm

Type	Model No.	Length of BL	Number of folds (BL)									
			2	4	6	8	10	12	14	16	18	20
Low type	JAA25L	$L_{min}$	34	68	102	136	170	204	238	272	306	340
		Stroke	134	268	402	536	670	804	938	1 072	1 206	1 340
High type	JAA25N	$L_{min}$	176	352	528	704	880	1 056	1 232	1 408	1 584	1 760
		Stroke	210	420	630	840	1 050	1 260	1 470	1 680	1 890	2 100
Low type	JAA30L	$L_{min}$	134	268	402	536	670	804	938	1 072	1 206	1 340
		Stroke	168	336	504	672	840	1 008	1 176	1 344	1 512	1 680
High type	JAA30N	$L_{min}$	176	352	528	704	880	1 056	1 232	1 408	1 584	1 760
		Stroke	210	420	630	840	1 050	1 260	1 470	1 680	1 890	2 100
Low type	JAA35L	$L_{min}$	176	352	528	704	880	1 056	1 232	1 408	1 584	1 760
		Stroke	210	420	630	840	1 050	1 260	1 470	1 680	1 890	2 100
High type	JAA35N	$L_{min}$	246	492	738	984	1 230	1 476	1 722	1 968	2 214	2 460
		Stroke	280	560	840	1 120	1 400	1 680	1 960	2 240	2 520	2 800
Low type	JAA45L	$L_{min}$	246	492	738	984	1 230	1 476	1 722	1 968	2 214	2 460
		Stroke	280	560	840	1 120	1 400	1 680	1 960	2 240	2 520	2 800
High type	JAA45N	$L_{min}$	386	772	1 158	1 544	1 930	2 316	2 702	3 088	3 474	3 860
		Stroke	420	840	1 260	1 680	2 100	2 520	2 940	3 360	3 780	4 200
Low type	JAA55L	$L_{min}$	246	492	738	984	1 230	1 476	1 722	1 968	2 214	2 460
		Stroke	280	560	840	1 120	1 400	1 680	1 960	2 240	2 520	2 800
High type	JAA55N	$L_{min}$	386	772	1 158	1 544	1 930	2 316	2 702	3 088	3 474	3 860
		Stroke	420	840	1 260	1 680	2 100	2 520	2 940	3 360	3 780	4 200
Low/high type	JAA65N*	$L_{min}$	386	772	1 158	1 544	1 930	2 316	2 702	3 088	3 474	3 860
		Stroke	420	840	1 260	1 680	2 100	2 520	2 940	3 360	3 780	4 200

\* Bellows for LA65 is for both low and high types.

**Note** : The values of an odd number BL quantity (3, 5, 7, ...) can be obtained by adding two values of the even number BL on the both sides, then by dividing the sum by 2.

**8. Reference number**

Reference numbers shall be set to individual NSK linear guide when its specifications are finalized, and it is indicated on its specification drawing.

Please specify the reference number, except design serial number, to identify the product when ordering, requiring estimates, or inquiring about specifications from NSK.

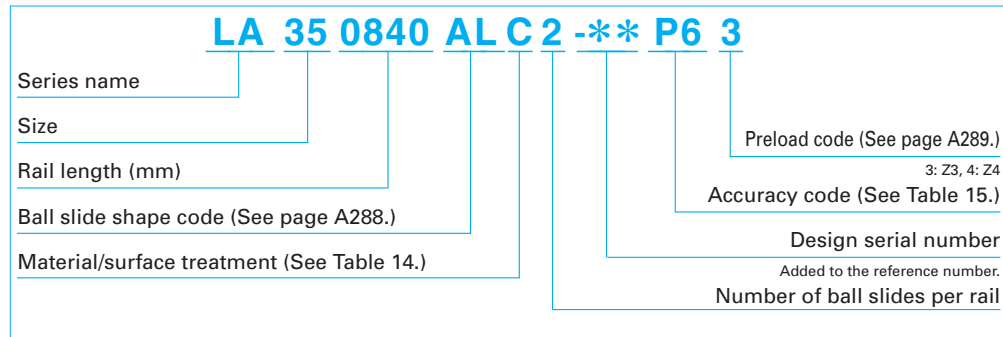

**Table 14 Material/surface treatment code**

Code	Description
C	Special high carbon steel (NSK standard)
D	Special high carbon steel with surface treatment
Z	Other, special

**Table 15 Accuracy code**

Accuracy	Standard (Without NSK K1)	With NSK K1
Ultra precision grade	P3	K3
Super precision grade	P4	K4
High precision grade	P5	K5
Precision grade	P6	K6

Note: Refer to pages A38 for NSK K1 lubrication unit.

9. Dimensions

LA-AL (High-load type / Standard)  
LA-BL (Super-high-load type / Long)

**LA 35 0840 AL C 2 -\*\* P6 3**

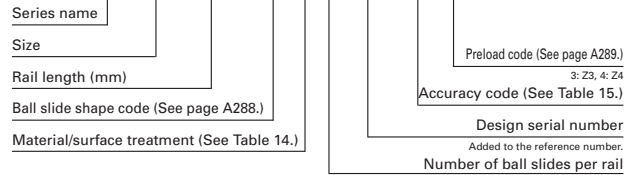

Front view of AL and BL types

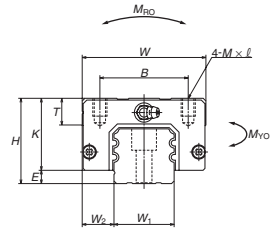

Side view of AL type

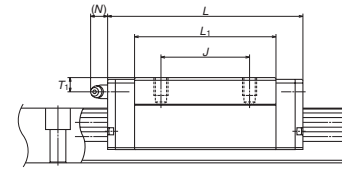

Side view of BL type

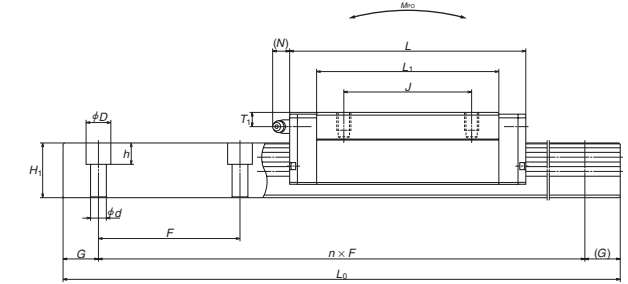

Model No.	Assembly			Ball slide										Width	Height		
	Height	Width	Length	Mounting hole				L <sub>1</sub>	K	T	Grease fitting					W <sub>1</sub>	H <sub>1</sub>
				B	J	M × pitch × ℓ	Hole size				T <sub>1</sub>	N					
<b>LA25AL</b>	36	5.5	12.5	48	79.8	35	35	M6×1×7	58	30.5	8	M6×0.75	6	11	23	22	
<b>LA25BL</b>					107.8	50			86								
<b>LA30AL</b>	42	7.5	16	60	100.2	40	40	M8×1.25×10	72	34.5	11	M6×0.75	6.5	11	28	28	
<b>LA30BL</b>					126.2	60			98								
<b>LA35AL</b>	48	7.5	18	70	110.6	50	50	M8×1.25×10	80	40.5	15	M6×0.75	8	11	34	30.8	
<b>LA35BL</b>					144.6	72			114								
<b>LA45AL</b>	60	10	20.5	86	141.4	60	60	M10×1.5×16	105	50	17	Rc1/8	10	13	45	36	
<b>LA45BL</b>					173.4	80			137								
<b>LA55AL</b>	70	12	23.5	100	165.4	75	75	M12 × 1.75×16	126	58	18	Rc1/8	11	13	53	43.2	
<b>LA55BL</b>					203.4	95			164								

Notes: 1) LA Series does not have a ball retainer. Be aware that balls fall out when the ball slide is withdrawn from the rail.

Unit: mm

Rail				Basic load rating						Weight			
Pitch	Mounting bolt hole	G	Max. length	<sup>2</sup> Dynamic		Static	Static moment (N-m)				Ball slide	Rail	
				[50km]	[100km]		C <sub>0</sub>	M <sub>P0</sub>		M <sub>Y0</sub>			
				C <sub>50</sub> (N)	C <sub>100</sub> (N)	(N)		One slide	Two slides	One slide	Two slides	(kg)	(kg/m)
60	7×11×9	20	3 960	30 000	23 900	50 000	290	410	2 490	410	2 490	0.5	3.7
				40 500	32 500	77 000	445	935	5 000	935	5 000	0.8	
80	9×14×12	20	4 000	47 000	37 000	77 500	535	820	4 800	820	4 800	0.8	5.8
				58 000	46 000	105 000	725	1 470	8 050	1 470	8 050	1.2	
80	9×14×12	20	4 000	61 500	49 000	98 000	845	1 130	6 750	1 130	6 750	1.3	7.7
				80 500	64 000	143 000	1 240	2 330	12 500	2 330	12 500	1.6	
105	14×20×17	22.5	3 990	91 000	72 000	148 000	1 840	2 210	12 900	2 210	12 900	2.5	12.0
				111 000	88 000	197 000	2 460	3 850	20 600	3 850	20 600	3.2	
120	16×23×20	30	3 960	139 000	111 000	215 000	3 150	3 800	22 000	3 800	22 000	3.9	17.2
				172 000	137 000	292 000	4 250	6 800	36 000	6 800	36 000	5.1	

2) The basic load rating comply with the ISO standard. (ISO 14728-1, 14728-2)

C<sub>50</sub>: the basic dynamic load rating for 50 km rated fatigue life  
C<sub>100</sub>: the basic dynamic load rating for 100 km rated fatigue life

LA-AN (High-load type / Standard)  
LA-BN (Super-high-load type / Long)

LA 35 0840 ANC 2 -\*\* P6 3

Series name	Preload code (See page A289.)
Size	3: Z3, 4: Z4
Rail length (mm)	Accuracy code (See Table 15.)
Ball slide shape code (See page A288.)	Design serial number
Material/surface treatment (See Table 14.)	Added to the reference number.
	Number of ball slides per rail

Front view of AN and BN types

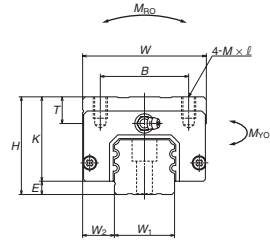

Side view of AN type

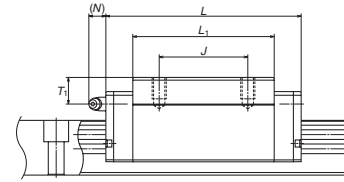

Side view of BN type

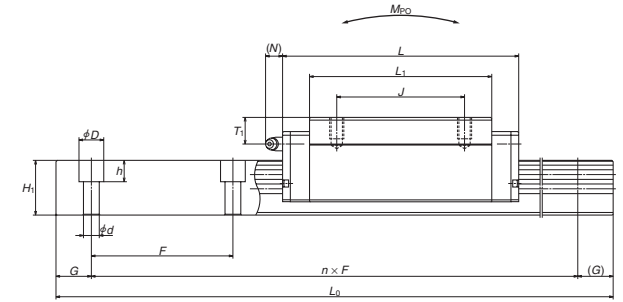

Unit: mm

Model No.	Assembly			Ball slide										Width	Height	
	Height	Width	Length	Mounting hole						Grease fitting						
				H	E	W <sub>2</sub>	W	L	B	J	M × pitch × l	L <sub>1</sub>	K			T
LA25AN	40	5.5	12.5	48	79.8	35	35	M6×1×10	58	34.5	12	M6×0.75	10	11	23	22
LA25BN					107.8		50		86							
LA30AN	45	7.5	16	60	100.2	40	40	M8×1.25×11	72	37.5	14	M6×0.75	9.5	11	28	28
LA30BN					126.2		60		98							
LA35AN	55	7.5	18	70	110.6	50	50	M8×1.25×12	80	47.5	15	M6×0.75	15	11	34	30.8
LA35BN					144.6		72		114							
LA45AN	70	10	20.5	86	141.4	60	60	M10×1.5×16	105	60	17	Rc1/8	20	13	45	36
LA45BN					173.4		80		137							
LA55AN	80	12	23.5	100	165.4	75	75	M12×1.75×18	126	68	18	Rc1/8	21	13	53	43.2
LA55BN					203.4		95		164							
LA65AN	90	14	31.5	126	196.2	76	70	M16×2×19	147	76	22	Rc1/8	19	13	63	55
LA65BN					256.2		120		207							

Notes: 1) LA Series does not have a ball retainer. Be aware that balls fall out when the ball slide is withdrawn from the rail.

Rail				Basic load rating						Weight			
Pitch	Mounting bolt hole	G	Max. length	<sup>2)</sup> Dynamic		Static	Static moment (N·m)				Ball slide	Rail	
				[50km]	[100km]		C <sub>0</sub>	M <sub>P0</sub>		M <sub>V0</sub>			
F	d × D × h	(reference)	L <sub>0max</sub>	C <sub>50</sub> (N)	C <sub>100</sub> (N)	(N)	One slide	Two slides	One slide	Two slides	(kg)	(kg/m)	
60	7×11×9	20	3 960	30 000	23 900	50 000	290	410	2 490	410	2 490	0.6	3.7
				40 500	32 500	77 000	445	935	5 000	935	5 000	0.9	
80	9×14×12	20	4 000	47 000	37 000	77 500	535	820	4 800	820	4 800	0.9	5.8
				58 000	46 000	105 000	725	1 470	8 050	1 470	8 050	1.3	
80	9×14×12	20	4 000	61 500	49 000	98 000	845	1 130	6 750	1 130	6 750	1.5	7.7
				80 500	64 000	143 000	1 240	2 330	12 500	2 330	12 500	2.1	
105	14×20×17	22.5	3 990	91 000	72 000	148 000	1 840	2 210	12 900	2 210	12 900	3.0	12.0
				111 000	88 000	197 000	2 460	3 850	20 600	3 850	20 600	3.9	
120	16×23×20	30	3 960	139 000	111 000	215 000	3 150	3 800	22 000	3 800	22 000	4.7	17.2
				172 000	137 000	292 000	4 250	6 800	36 000	6 800	36 000	6.1	
150	18×26×22	35	3 900	260 000	206 000	420 000	7 300	9 050	51 000	9 050	51 000	7.7	25.9
				340 000	269 000	615 000	10 700	18 700	95 000	18 700	95 000	10.8	

2) The basic load rating comply with the ISO standard. (ISO 14728-1, 14728-2)

C<sub>50</sub>: the basic dynamic load rating for 50 km rated fatigue life  
C<sub>100</sub>: the basic dynamic load rating for 100 km rated fatigue life

LA-EL (High-load type / Standard)  
LA-GL (Super-high-load type / Long)

**LA 35 0840 EL C 2 -\*\* P6 3**

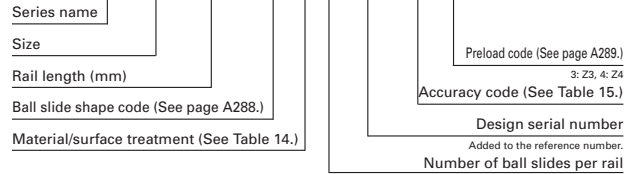

Front view of EL and GL types

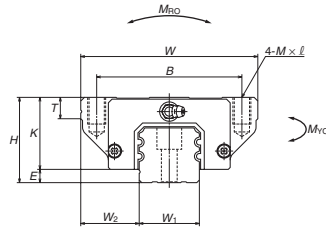

Side view of EL type

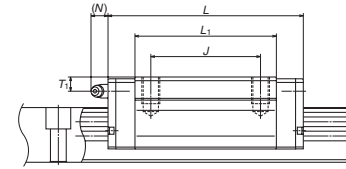

Side view of GL type

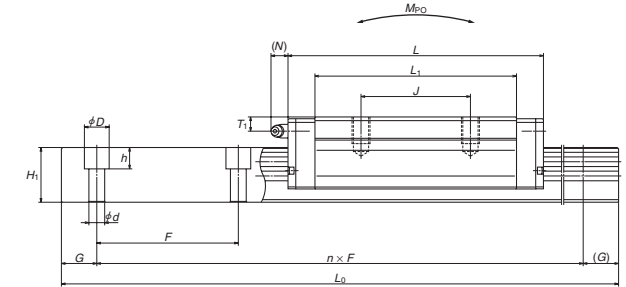

Unit: mm

Model No.	Assembly			Ball slide											Width	Height
	Height	Width	Length	Mounting hole						Grease fitting			Width	Height		
				$H$	$E$	$W_2$	$W$	$L$	$B$	$J$	$M \times \text{pitch} \times l$	$L_1$				
<b>LA25EL</b>	36	5.5	23.5	70	79.8	57	45	M8×1.25×12	58	30.5	11	M6×0.75	6	11	23	22
<b>LA25GL</b>					107.8				86							
<b>LA30EL</b>	42	7.5	31	90	100.2	72	52	M10×1.5×16	72	34.5	11	M6×0.75	6.5	11	28	28
<b>LA30GL</b>					126.2				98							
<b>LA35EL</b>	48	7.5	33	100	110.6	82	62	M10×1.5×15	80	40.5	12	M6×0.75	8	11	34	30.8
<b>LA35GL</b>					144.6				114							
<b>LA45EL</b>	60	10	37.5	120	141.4	100	80	M12×1.75×18	105	50	13	Rc1/8	10	13	45	36
<b>LA45GL</b>					173.4				137							
<b>LA55EL</b>	70	12	43.5	140	165.4	116	95	M14×2×21	126	58	15	Rc1/8	11	13	53	43.2
<b>LA55GL</b>					203.4				164							
<b>LA65EL</b>	90	14	53.5	170	196.2	142	110	M16×2×24	147	76	22	Rc1/8	19	13	63	55
<b>LA65GL</b>					256.2				207							

Notes: 1) LA Series does not have a ball retainer. Be aware that balls fall out when the ball slide is withdrawn from the rail.

Rail				Basic load rating								Weight	
Pitch	Mounting bolt hole	G	Max. length	<sup>2)</sup> Dynamic		Static	Static moment (N·m)				Ball slide	Rail	
				[50km]	[100km]		$C_0$	$M_{P0}$		$M_{Y0}$			
				$C_{50}$ (N)	$C_{100}$ (N)	(N)		One slide	Two slides	One slide	Two slides	(kg)	(kg/m)
60	7×11×9	20	3 960	30 000	23 900	50 000	290	410	2 490	410	2 490	0.8	3.7
				40 500	32 500	77 000	445	935	5 000	935	5 000	1.1	
80	9×14×12	20	4 000	47 000	37 000	77 500	535	820	4 800	820	4 800	1.3	5.8
				58 000	46 000	105 000	725	1 470	8 050	1 470	8 050	1.8	
80	9×14×12	20	4 000	61 500	49 000	98 000	845	1 130	6 750	1 130	6 750	1.9	7.7
				80 500	64 000	143 000	1 240	2 330	12 500	2 330	12 500	2.6	
105	14×20×17	22.5	3 990	91 000	72 000	148 000	1 840	2 210	12 900	2 210	12 900	3.3	12.0
				111 000	88 000	197 000	2 460	3 850	20 600	3 850	20 600	4.3	
120	16×23×20	30	3 960	139 000	111 000	215 000	3 150	3 800	22 000	3 800	22 000	5.5	17.2
				172 000	137 000	292 000	4 250	6 800	36 000	6 800	36 000	7.2	
150	18×26×22	35	3 900	260 000	206 000	420 000	7 300	9 050	51 000	9 050	51 000	11.0	25.9
				340 000	269 000	615 000	10 700	18 700	95 000	18 700	95 000	15.5	

2) The basic load rating comply with the ISO standard. (ISO 14728-1, 14728-2)

$C_{50}$ : the basic dynamic load rating for 50 km rated fatigue life  
 $C_{100}$ : the basic dynamic load rating for 100 km rated fatigue life



LA-FL (High-load type / Standard)  
LA-HL (Super-high-load type / Long)

**LA 35 0840 FL C 2 -\*\* P6 3**

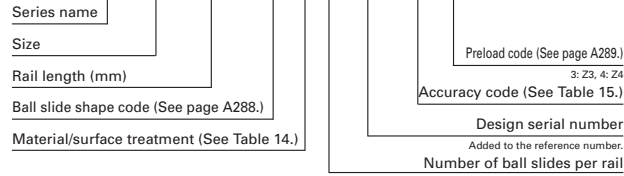

Front view of FL and HL types

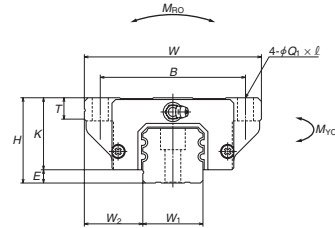

Side view of FL type

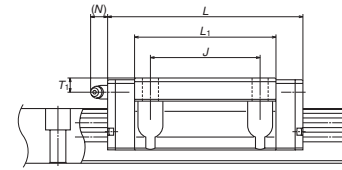

Side view of HL type

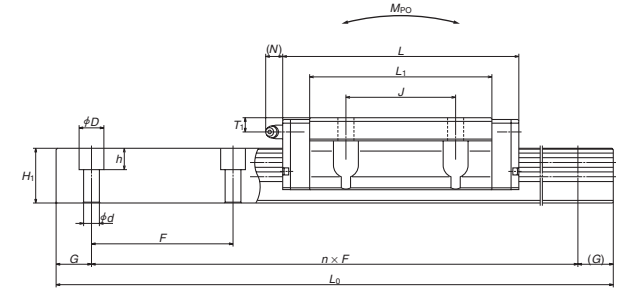

Model No.	Assembly			Ball slide											Width	Height		
	Height	E	W <sub>2</sub>	Width	Length	Mounting hole			L <sub>1</sub>	K	T	Grease fitting					W <sub>1</sub>	H <sub>1</sub>
						B	J	M × pitch × ℓ				Hole size	T <sub>1</sub>	N				
<b>LA25FL</b>	36	5.5	23.5	70	79.8	57	45	7×10	58	30.5	11	M6×0.75	6	11	23	22		
<b>LA25HL</b>					107.8												86	
<b>LA30FL</b>	42	7.5	31	90	100.2	72	52	9×12	72	34.5	11	M6×0.75	6.5	11	28	28		
<b>LA30HL</b>					126.2												98	
<b>LA35FL</b>	48	7.5	33	100	110.6	82	62	9×13	80	40.5	12	M6×0.75	8	11	34	30.8		
<b>LA35HL</b>					144.6												114	
<b>LA45FL</b>	60	10	37.5	120	141.4	100	80	11×15	105	50	13	Rc1/8	10	13	45	36		
<b>LA45HL</b>					173.4												137	
<b>LA55FL</b>	70	12	43.5	140	165.4	116	95	14×18	126	58	15	Rc1/8	11	13	53	43.2		
<b>LA55HL</b>					203.4												164	
<b>LA65FL</b>	90	14	53.5	170	196.2	142	110	16×23	147	76	22	Rc1/8	19	13	63	55		
<b>LA65HL</b>					256.2												207	

Notes: 1) LA Series does not have a ball retainer. Be aware that balls fall out when the ball slide is withdrawn from the rail.

Unit: mm

Rail		Basic load rating								Weight			
Pitch	Mounting bolt hole	G	Max. length	<sup>2)</sup> Dynamic		Static	Static moment (N·m)				Ball slide	Rail	
				[50km]	[100km]		C <sub>0</sub>	M <sub>P0</sub>		M <sub>Y0</sub>			
F	d × D × h	(reference)	L <sub>0max</sub>	C <sub>50</sub> (N)	C <sub>100</sub> (N)	(N)		One slide	Two slides	One slide	Two slides	(kg)	(kg/m)
60	7×11×9	20	3 960	30 000	23 900	50 000	290	410	2 490	410	2 490	0.8	3.7
				40 500	32 500	77 000	445	935	5 000	935	5 000	1.1	
80	9×14×12	20	4 000	47 000	37 000	77 500	535	820	4 800	820	4 800	1.3	5.8
				58 000	46 000	105 000	725	1 470	8 050	1 470	8 050	1.8	
80	9×14×12	20	4 000	61 500	49 000	98 000	845	1 130	6 750	1 130	6 750	1.9	7.7
				80 500	64 000	143 000	1 240	2 330	12 500	2 330	12 500	2.6	
105	14×20×17	22.5	3 990	91 000	72 000	148 000	1 840	2 210	12 900	2 210	12 900	3.3	12.0
				111 000	88 000	197 000	2 460	3 850	20 600	3 850	20 600	4.3	
120	16×23×20	30	3 960	139 000	111 000	215 000	3 150	3 800	22 000	3 800	22 000	5.5	17.2
				172 000	137 000	292 000	4 250	6 800	36 000	6 800	36 000	7.2	
150	18×26×22	35	3 900	260 000	206 000	420 000	7 300	9 050	51 000	9 050	51 000	11.0	25.9
				340 000	269 000	615 000	10 700	18 700	95 000	18 700	95 000	15.5	

2) The basic load rating comply with the ISO standard. (ISO 14728-1, 14728-2)

C<sub>50</sub>: the basic dynamic load rating for 50 km rated fatigue life  
C<sub>100</sub>: the basic dynamic load rating for 100 km rated fatigue life