

Motors

MCA asynchronous servo motors

2 to 1,100 Nm

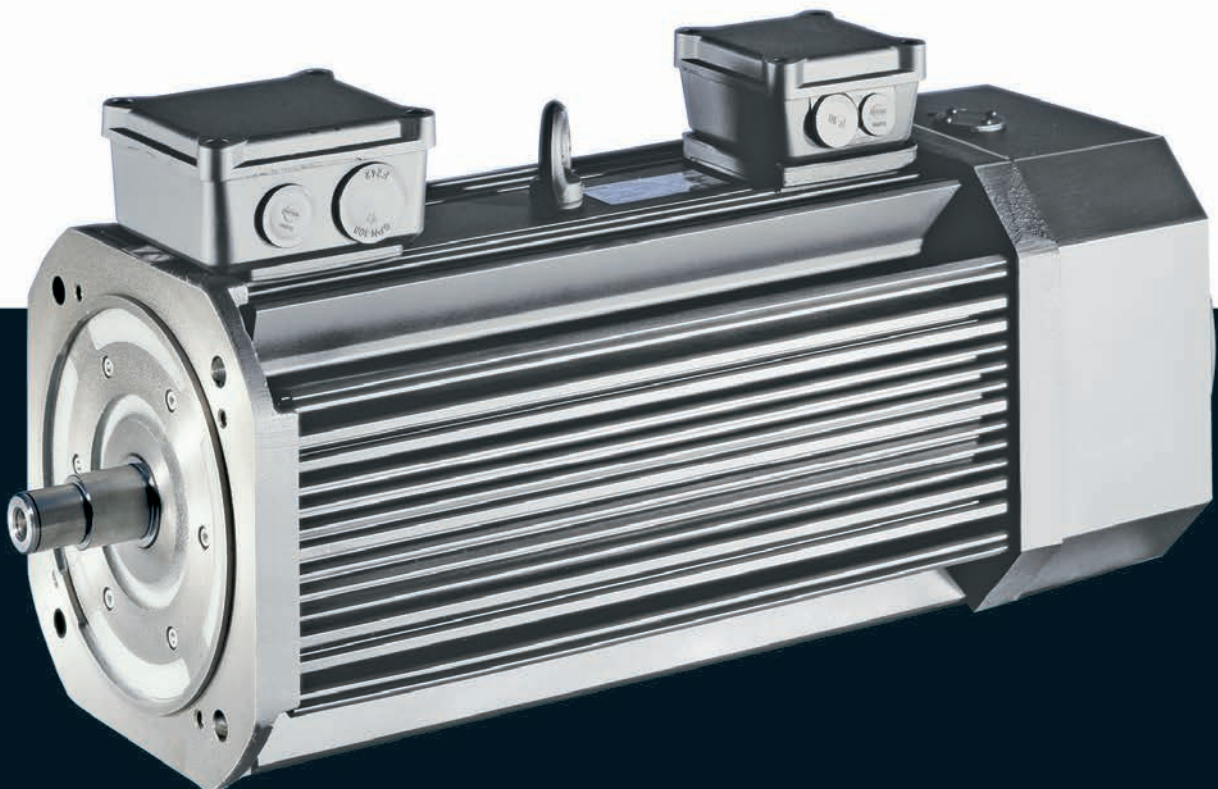

MCA asynchronous servo motors



Contents

General information	List of abbreviations	5.4 - 4
	Product key	5.4 - 6
	Product information	5.4 - 8
	Functions and features	5.4 - 9
	Dimensioning	5.4 - 11
Technical data	Standards and operating conditions	5.4 - 19
	Permissible radial and axial forces	5.4 - 20
	Rated data, non-ventilated	5.4 - 22
	Rated data, IP54 forced ventilated	5.4 - 23
	Rated data, IP23s forced ventilated	5.4 - 24
	Selection tables, Servo Drives 9400 HighLine	5.4 - 25
	Selection tables, Inverter Drives 8400 TopLine	5.4 - 32
	Selection tables, Servo Drives ECS	5.4 - 38
	Selection tables, Servo Inverter 9300	5.4 - 41
	Torque characteristics	5.4 - 47
	Dimensions, self-ventilated	5.4 - 66
	Dimensions, forced ventilated	5.4 - 68
	Accessories	Permanent magnet holding brake
Spring-applied holding brake		5.4 - 78
Resolver		5.4 - 80
Incremental encoder and SinCos absolute value encoder		5.4 - 81
Blowers		5.4 - 83
Temperature monitoring		5.4 - 84
Terminal box		5.4 - 85
ICN connector	5.4 - 87	



List of abbreviations

$\eta_{100\%}$	[%]	Efficiency
$\cos \phi$		Power factor
du/dt	[kV/ μ s]	Insulation resistance
$F_{ax,-}$	[N]	Min. axial force
$F_{ax,+}$	[N]	Max. axial force
$f_{in,max}$	[Hz]	Max. input frequency
f_{max}	[kHz]	Limit frequency
f_{max}	[kHz]	Max. switching frequency
f_N	[Hz]	Rated frequency
F_{rad}	[N]	Max. radial force
H_{max}	[m]	Site altitude
I_0	[A]	Standstill current
I_{max}	[A]	Max. short-time DC-bus current
I_{max}	[A]	Max. current
I_{max}	[A]	Max. current consumption
I_{max}	[A]	Max. current
I_{max}	[A]	Max. DC-bus current
I_N	[A]	Rated current
J	[kgcm ²]	Moment of inertia
J_{MB}	[kgcm ²]	Moment of inertia
$KE_{LL\ 150\ ^\circ C}$	[V / 1000 rp]	Voltage constant
$Kt_{0\ 150\ ^\circ C}$	[Nm/A]	Torque constant
L	[mH]	Mutual inductance
$L_{1\sigma}$	[mH]	Stator leakage inductance
$L_{2\sigma}$	[mH]	Rotor leakage inductance
L_N	[mH]	Rated inductance
m	[kg]	Mass
M_0	[Nm]	Stall torque
$M_{0,max}$	[Nm]	Max. standstill torque
M_{av}	[Nm]	Average dynamic torque
M_{max}	[Nm]	Max. torque
M_N	[Nm]	Rated torque
n_{eto}	[r/min]	Transition speed
n_k	[r/min]	Speed
n_{max}	[r/min]	Max. speed

n_N	[r/min]	Rated speed
P_N	[kW]	Rated power
Q_E	[J]	Maximum switching energy
R	[Ω]	Insulation resistance
R	[Ω]	Min. insulation resistance
R_1	[Ω]	Stator impedance
R_2	[Ω]	Charging resistor
R_2	[Ω]	Rotor impedance
$R_{UV\ 150\ ^\circ C}$	[Ω]	Stator impedance
$R_{UV\ 20\ ^\circ C}$	[Ω]	Stator impedance
$S_{h\u00fc}$	[1/h]	Transition operating frequency
T	[$^\circ C$]	Operating temperature
T	[$^\circ C$]	Rated temperature
T	[$^\circ C$]	Max. ambient temperature of bearing
T	[$^\circ C$]	Max. surface temperature
T	[$^\circ C$]	Max. ambient temperature for transport
T	[$^\circ C$]	Min. ambient storage temperature
T	[$^\circ C$]	Min. ambient temperature for transport
T	[$^\circ C$]	Ambient temperature
t_1	[ms]	Engagement time
t_2	[ms]	Disengagement time
$T_{opr,max}$	[$^\circ C$]	Max. ambient operating temperature
$T_{opr,min}$	[$^\circ C$]	Min. ambient operating temperature
$U_{in,max}$	[V]	Max. input voltage
$U_{in,min}$	[V]	Min. input voltage
U_{max}	[V]	Max. mains voltage
U_{max}	[V]	Min. input voltage
U_{min}	[V]	Min. mains voltage
$U_{N, AC}$	[V]	Rated voltage
$U_{N, DC}$	[V]	Rated voltage
Z_{ro}	[Ω]	Rotor impedance
Z_{rs}	[Ω]	Impedance
Z_{so}	[Ω]	Stator impedance

MCA asynchronous servo motors

General information



List of abbreviations

CE	Communauté Européenne
CSA	Canadian Standards Association
DIN	Deutsches Institut für Normung e.V.
EMC	Electromagnetic compatibility
EN	European standard
GOST	Certificate for Russian Federation
IEC	International Electrotechnical Commission
IM	International Mounting Code
IP	International Protection Code
NEMA	National Electrical Manufacturers Association
UkrSEPRO	Certificate for Ukraine
UL	Underwriters Laboratory Listed Product
UR	Underwriters Laboratory Recognized Product
VDE	Verband deutscher Elektrotechniker (Association of German Electrical Engineers)

MCA asynchronous servo motors

General information



Product key

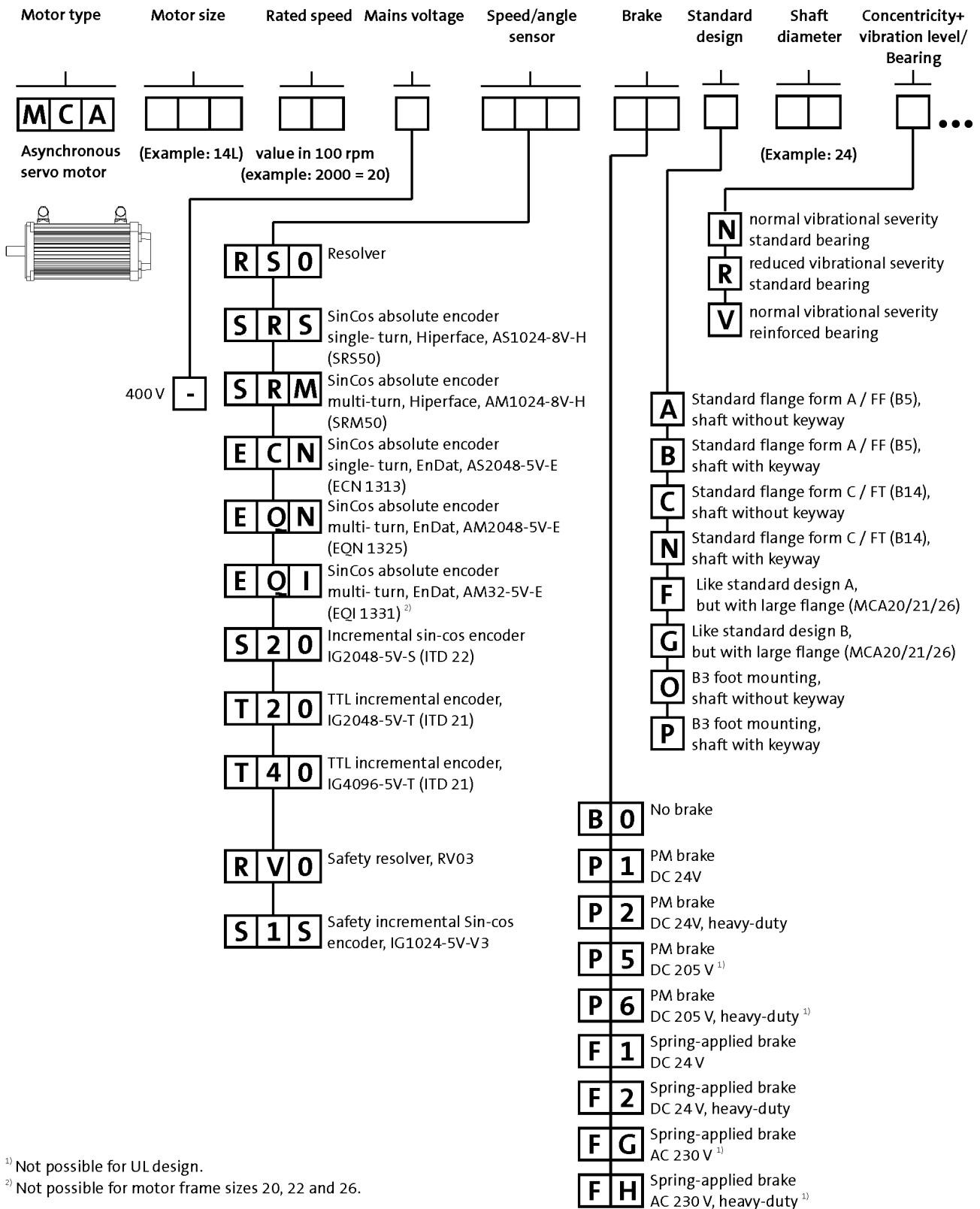

¹⁾ Not possible for UL design.

²⁾ Not possible for motor frame sizes 20, 22 and 26.

MCA asynchronous servo motors

General information



Product key

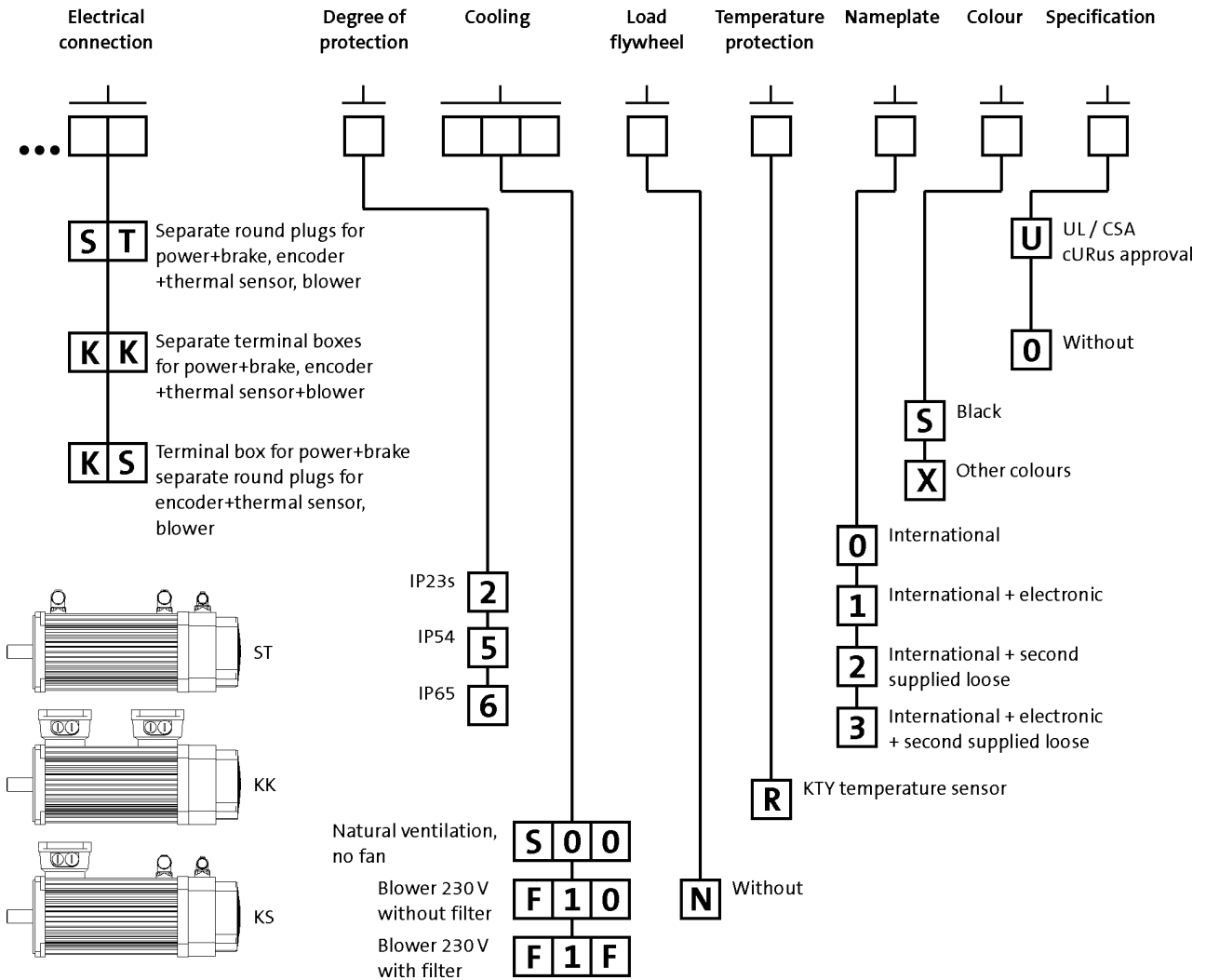

MCA asynchronous servo motors

General information



Product information

An application-oriented structure, low moments of inertia, compact dimensions and a high degree of intrinsic operational reliability characterise these robust and dynamic motors.

The compact design and the low moment of inertia allow these motors to be used in dynamic applications. If your application calls for a broad speed setting range and a robust construction, then the choice is easy: MCA asynchronous servo motors from Lenze.

Whether as a self-ventilated version or with a blower – with a power range from 0.8 to 53.8 kW, the MCA asynchronous servo motors offer rated torque values of up to 280 Nm and peak torque values of up to 1100 Nm. In comparison to standard three-phase AC motors, these servo motors have the edge in terms of lower moments of inertia, lower weight and higher maximum speeds.

Advantages

- High dynamic performance thanks to low moments of inertia
- Compact size with high power density
- Robust regenerative resolver system – alternatively SinCos and incremental encoder for the highest precision
- Easy to install and service friendly thanks to use of SpeedTec connectors
- Terminal box optional up to MCA21 MCA22 and 26 with three-part terminal box
- Protection: IP23, IP54, IP65 optional for naturally ventilated servo motors
- cURus-approved, GOST-certified, CE, RoHS-compliant
- High maximum speeds
- Wide speed setting range
- Field weakening operation usable
- Electronic nameplate

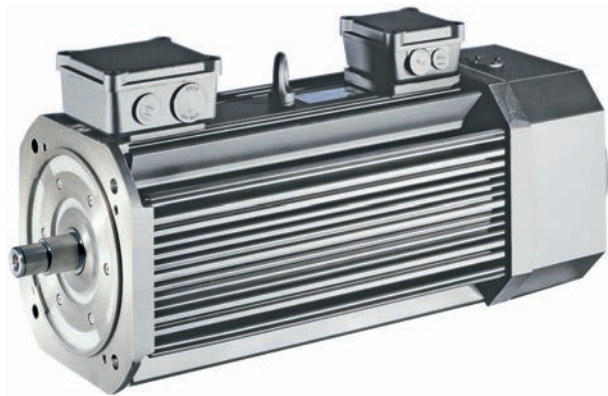

MCA21 asynchronous servo motor

MCA asynchronous servo motors

General information



Functions and features

	MCA10	MCA13	MCA14	MCA17	MCA19
Design					
	B14-FT85 B5-FF100	B14-FT130 B5-FF130	B14-FT130 B5-FF165		B14-FT130 B5-FF215
Shaft end (with and without keyway)					
	14 x 30	19 x 40	24 x 50		28 x 60
A end shield	Oil-tight Not oil-tight				
Brake					
Spring-applied brake					
Permanent magnetic brake	DC 24 V AC 230 V ¹⁾ DC 205 V ¹⁾				
Speed and angle encoder					
	Resolver SinCos single-turn/multi-turn Incremental encoder				
Cooling					
Without blower	Naturally ventilated				
Axial blower, 1 phase	230 V; 50 Hz				
Temperature sensor					
Thermal detector	KTY				
Motor connection: plug connector					
	Power + brake Encoder + thermal sensor Blower				
Motor connection: terminal box					
	Power + brake Encoder + thermal sensor	Power + brake Encoder + thermal sensor + blower			
Motor connection: Terminal box + plug connector					
Terminal box	Power + brake Encoder + thermal sensor				
Plug connector	Blower				
Shaft bearings					
Bearing type	Deep-groove ball bearing with high-temperature resistant grease, sealing disc or cover plate				
Position of the locating bearing	Drive end Standard motors (B3, B5, B14): side B Motors for gearbox direct mounting: side A				
Installation of the locating bearing					
Colour	RAL9005M				

¹⁾ Not possible for UR version.

MCA asynchronous servo motors

General information



Functions and features

	MCA20	MCA21	MCA22	MCA26
Design				
	B3 B35-FF215 B35-FF265	B14-FT130 B5-FF215 B5-FF265	B3 B35-FF265	B3 B35-FF265 B35-FF350
Shaft end (with and without keyway)	38 x 80			55 x 110
A end shield	Oil-tight Not oil-tight			
Brake				
Spring-applied brake	DC 24 V AC 230 V ¹⁾			DC 24 V AC 230 V ¹⁾
Permanent magnetic brake		DC 24 V AC 230 V ¹⁾ DC 205 V ¹⁾		
Speed and angle encoder	Resolver SinCos single-turn/multi-turn Incremental encoder			
Cooling				
Without blower		Naturally ventilated		
Axial blower, 1 phase	230 V; 50 Hz 230 V; 60 Hz	230 V; 50 Hz		230 V; 50 Hz 230 V; 60 Hz
Temperature sensor				
Thermal detector	KTY			
Motor connection: plug connector				
	Power + brake Encoder + thermal sensor Blower			
Motor connection: terminal box				
		Power + brake Encoder + thermal sensor + blower		
Motor connection: Terminal box + plug connector				
Terminal box	Power + brake	Power + brake Encoder + thermal sensor		Power + brake
Plug connector	Encoder + thermal sensor Blower	Blower		Encoder + thermal sensor Blower
Shaft bearings				
Bearing type	Deep-groove ball bearing with high-temperature resistant grease, sealing disc or cover plate			
Position of the locating bearing	Non-drive end	Drive end Standard motors (B3, B5, B14): side B Motors for gearbox direct mounting: side A		Non-drive end
Installation of the locating bearing	insulation			insulation
Colour	RAL9005M			

¹⁾ Not possible for UR version.

MCA asynchronous servo motors



General information

Dimensioning

Speed-dependent safety functions

Single encoder concepts with resolvers

Servo motors can perform speed-dependent safety functions for safe speed and / or safe relative position monitoring in a drive system with the Servo Drives 9400. The SM301 safety module, which can be integrated in the Servo Drives 9400, is used to implement these functions. When planning systems/installations of this kind, the following must always be observed:

When using just one single feedback system in the environment of these safety applications, the applicable safety engineering standard IEC 61800-5-2 [Adjustable speed electrical power drive systems - Part: 5-2: Safety requirements - Functional] stipulates special requirements for the connection between feedback system and motor shaft. This is due to the fact that two-channel safety systems at this point in the mechanical system are actually designed as single-channel systems. If this mechanical connection is designed with considerable overdimensioning, the standard permits exclusion of the fault "encoder-shaft breakage" or "encoder-shaft slip". As such, acceleration limit values must not be exceeded for the individual drive solutions. You can find the limit values in the corresponding feedback data of the individual motor ranges.

Speed-dependent safety functions in connection with the SM301 safety module

For the following speed-dependent safety functions, the motor-feedback system combinations listed in the following table are available:

- Safe stop 1 (SS1)
- Safe operational stop (SOS)
- Safely Limited Speed (SLS)
- Safe Maximum Speed (SMS)
- Safe direction (SDI)
- Operation mode selector (OMS) with confirmation (ES)
- Safe speed monitor (SSM)
- Safely limited increment (SLI).

Encoder type	Encoder type	Product key	Feedback Design	Safe speed monitoring
SinCos incremental	Single-turn	IG1024-5V-V3	2-encoder concept	PL e/SIL 3 up to PL e / SIL 3
Resolver		RV03		

MCA asynchronous servo motors



General information

Dimensioning

Cooling effect of mounting flange

Mounting on a thermally conducting / insulating plate or machine chassis has an influence on heating up the motor, particularly when using naturally ventilated motors.

The motor rating data specified in the catalogue applies when mounting on a steel plate with free convection with the following dimensions:

- MCA10 / 13: 270 x 270 mm
- MCA14 / 17: 330 x 330 mm
- MCA19 to 26: 450 x 450 mm

Vibrational severity

		MCA10	MCA13	MCA14	MCA17	MCA19	MCA20	MCA21	MCA22	MCA26
Vibrational severity										
IEC/EN 60034-14		A			B		A	B		A
Maximum r.m.s. value of the vibration velocity ¹⁾	[mm/s]	1.60			0.70		1.60	0.70		1.60

¹⁾ Free suspension

- ▶ at n = 600 to 3,600 rpm



Dimensioning

Concentricity and axial run-out of the mounting flanges and smooth running of the shaft ends

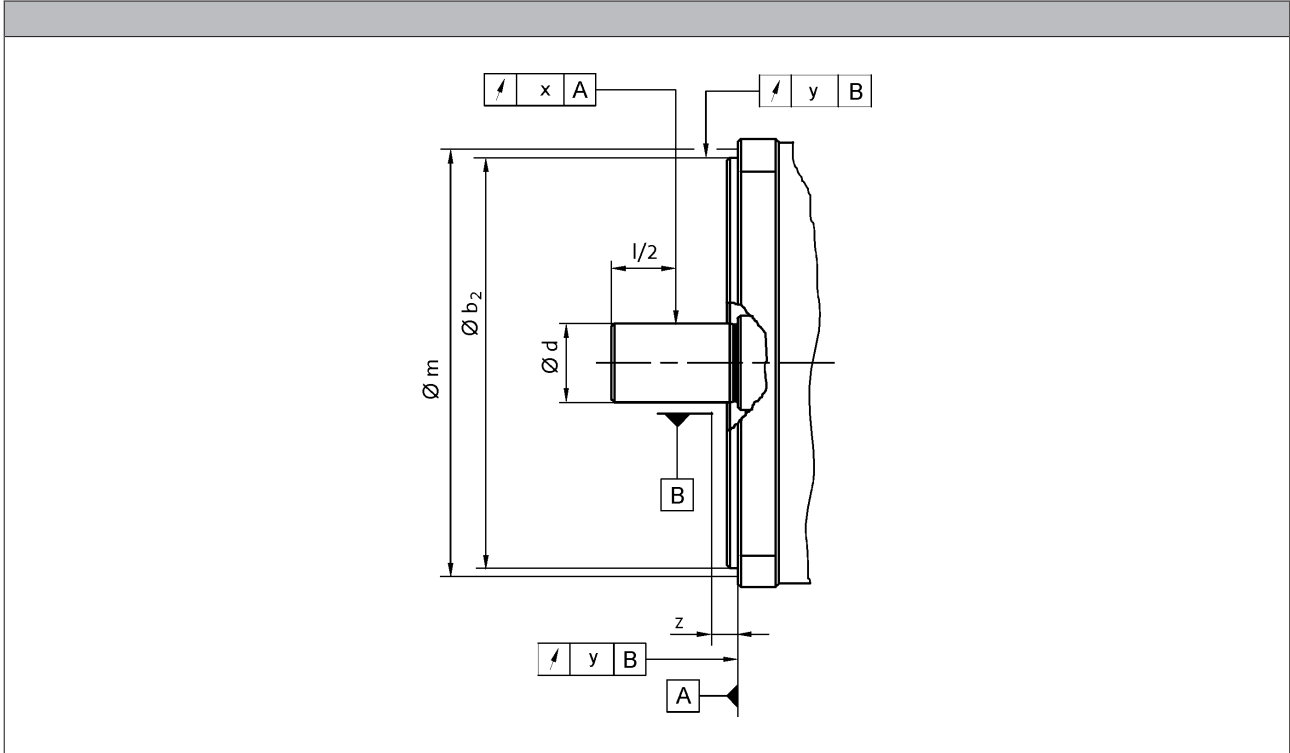

				MCA10		MCA13		MCA14		MCA17		MCA19			
Flange size				FF100	FT85	FF130	FT130	FF165	FT130	FF165	FT130	FF215	FT130		
Dimensions	b_2	j6	[mm]	80	70	110		130	110	130	110	180	110		
	b_2	h6	[mm]												
	d	k6	[mm]	14		19		24				28			
	d	m6	[mm]												
Distance															
Measuring diameter	m		[mm]	113	98.0	149		188	149	188	149	239	149		
Dial gauge holder for flange check	z	+/- 1	[mm]	10.0											
Concentricity															
IEC 60072				Normal class						Precision class					
Value	y		[mm]	0.080		0.10		0.050							
Linear movement															
IEC 60072				Normal class						Precision class					
Value	y		[mm]	0.080		0.10		0.050							
Smooth running															
IEC 60072				Normal class						Precision class					
Value	x		[mm]	0.035		0.040		0.021							

- Limit values for checking the smooth running of the shaft ends as well as the concentricity and axial run-out of the mounting flange to IEC 60072

MCA asynchronous servo motors

General information



Dimensioning

Concentricity and axial run-out of the mounting flanges and smooth running of the shaft ends

				MCA20		MCA21			MCA22	MCA26		
Flange size				FF215	FF265	FF215	FF265	FT130	FF265	FF350		
Dimensions												
	b ₂	j6	[mm]	180	230	180	230	110	230			
	b ₂	h6	[mm]								300	
	d	k6	[mm]	38								
	d	m6	[mm]							55		
Distance												
Measuring diameter	m		[mm]	239	289	239	289	149	289	384		
Dial gauge holder for flange check	z	+/- 1	[mm]	10.0								
Concentricity												
IEC 60072				Normal class		Precision class			Normal class			
Value	y		[mm]	0.10		0.050			0.10			
Linear movement												
IEC 60072				Normal class		Precision class			Normal class			
Value	y		[mm]	0.10		0.050			0.10			
Smooth running												
IEC 60072				Normal class		Precision class			Normal class			
Value	x		[mm]	0.050		0.060			0.050	0.060		

- Limit values for checking the smooth running of the shaft ends as well as the concentricity and axial run-out of the mounting flange to IEC 60072

MCA asynchronous servo motors

General information



Dimensioning

Notes on the selection tables

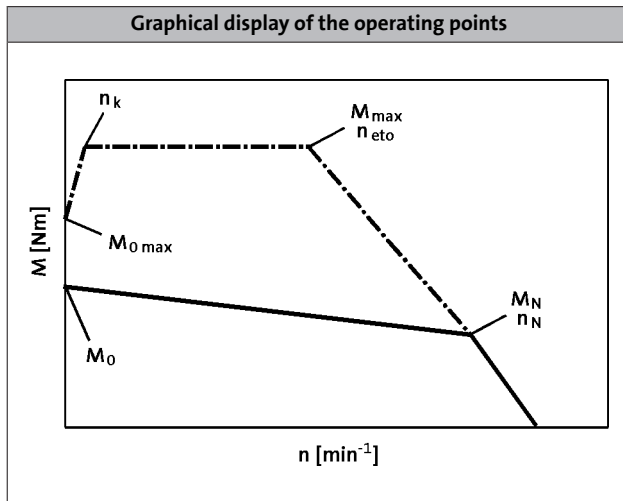

Please note:

- With an active load (e.g. vertical drive axes, hoists, test benches, unwinders), $M_{0\max}$ must be taken into account
- With a passive load (e.g. horizontal drive axes), M_{\max} can generally be used
- At speeds $< n_k$, the inverter-specific torque $M_{0\max}$ that can be achieved is lower than M_{\max}
- On the servo inverters, the switching frequency-dependent overload capacity has been taken into account in the factory settings. For further information, please refer to the Servo-Inverters catalogue.

	n_k [r/min]
MCA	150
MQA	

Further selection tables with different switching frequencies are available with the following codes:

- DS_ZT_MCS_0001
- DS_ZT_MCA_0001
- DS_ZT_MDSKS_0001
- DS_ZT_MDFKS_0001

Simply enter this code (e.g. DS_ZT_MCS_0001) as a search string at Lenze website and you will be given the information immediately in the form of a PDF format.



Dimensioning

Notes on the torque characteristics

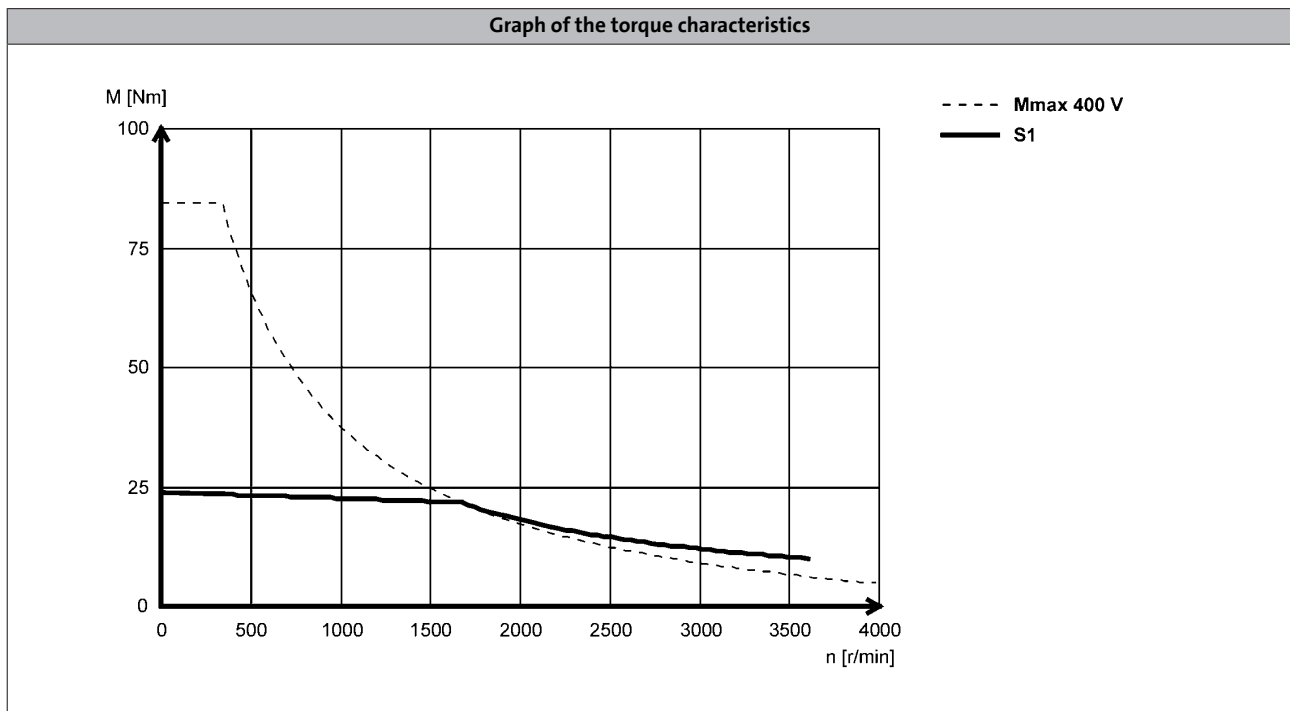

With asynchronous servo motors, two characteristics are shown in each case. The characteristics for continuous operation (S1) show the speed-dependent constant torque of the motor when operating with a servo inverter that itself is operated at a constant switching frequency. The limit torque characteristics correspond to those that come about during operation of the motor with the largest possible 9400 Servo Drive in each case (see selection tables). The servo inverter is set to a variable switching frequency here.

5.4

Characteristics in the Internet

You can find the torque characteristic for inverter-motor combinations on the Internet. This lists all useful combinations with the servo inverters 9400, 9300, ECS and Inverter Drives 8400 TopLine. These characteristics are each determined using the factory default settings of the inverters:

- 9400 with variable switching frequency.
This means that up to 6-fold overcurrent can be applied in borderline cases.
- 9300 and ECS with fixed switching frequency.
- 8400 TopLine with variable switching frequency.

The continuous operation characteristics (S1) show the inverter-independent motor rating values

Further information on the terms switching frequency and factory default settings can be found in the operating manual of the respective servo inverter.

MCA asynchronous servo motors



General information

Dimensioning

Influence of ambient temperature and site altitude

The information relating to the servo motors in the tables and graphs is valid for a maximum ambient temperature (T_{opr}) of 40 °C and a site altitude (H) up to 1000 m above sea level. The torque correction factor (k_{M1}) shall be applied to the S1 torque characteristic ($M_0...M_N$) in the event of differing installation conditions.

- The maximum permissible ambient temperature (T_{opr}) for servo motors with blowers is 40 °C

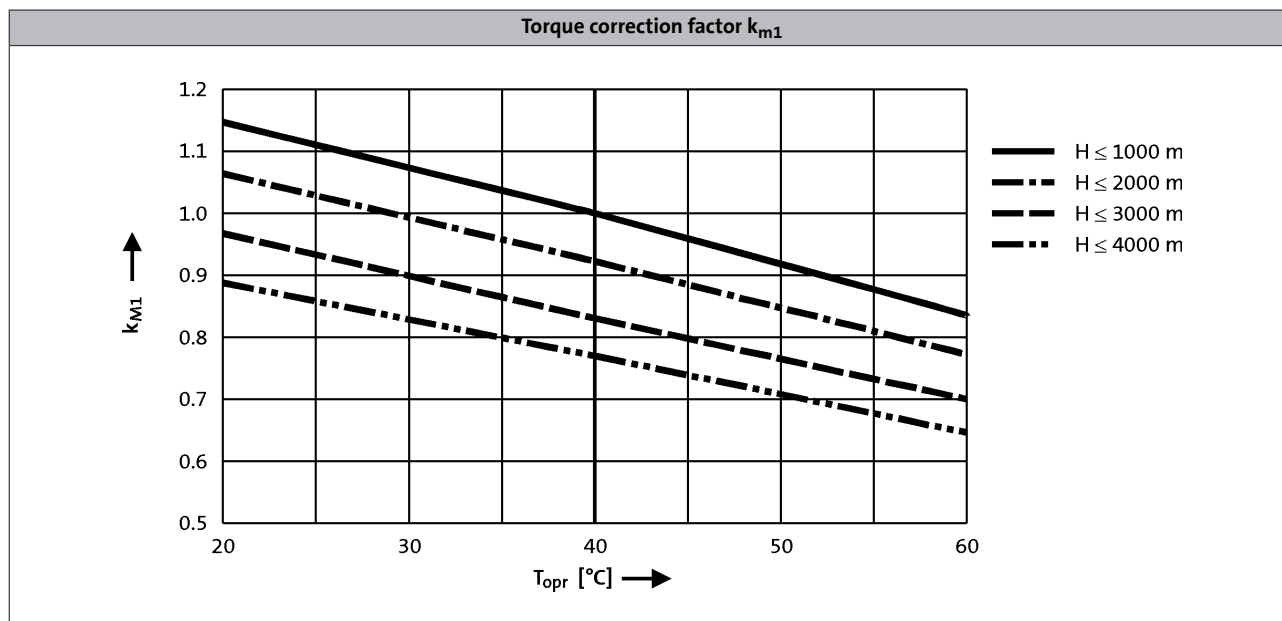

MCA asynchronous servo motors

General information



MCA asynchronous servo motors

Technical data



Standards and operating conditions

			MCA	
Cooling type			Naturally ventilated	Blower
Degree of protection				
EN 60529			IP54 IP65	IP54 IP23s ²⁾
Temperature class				
IEC/EN 60034-1; utilisation			F	
IEC/EN 60034-1; insulation system (enamel-insulated wire)			H	
Approval				
Class			cURus ^{4, 5)} GOST-R UkrSepro	
Max. voltage load				
IEC/TS 60034-25			Pulse voltage limiting curve A	
Smooth running				
IEC 60072			Precision class ¹⁾ Normal class	
Linear movement				
IEC 60072			Precision class ¹⁾ Normal class	
Concentricity				
IEC 60072			Precision class ¹⁾ Normal class	
Mechanical ambient conditions (vibration)				
IEC/EN 60721-3-3			3M6	
Min. ambient operating temperature				
Without brake	T _{opr,min}	[°C]	-20	-15
With brake	T _{opr,min}	[°C]	-10	
Max. ambient temperature for operation				
	T _{opr,max}	[°C]	40	
Max. surface temperature				
	T	[°C]	140	110
Mechanical tolerance				
Flange centring diameter			b ₂ ≤ 230 mm = j6 b ₂ > 230 mm = h6	
Shaft diameter			d ≤ 50 mm = k6 d > 50 mm = m6	
Site altitude				
Amsl	H _{max}	[m]	4000	

¹⁾ MCA14, 17, 19 and 21.

²⁾ MCA20, 22 and 26.

³⁾ Not possible on MCA20.

⁴⁾ Recognized component File No. E 210321.

⁵⁾ MCA20X29, MCA21X35 with circular connector for motor connection only
UR



Permissible radial and axial forces

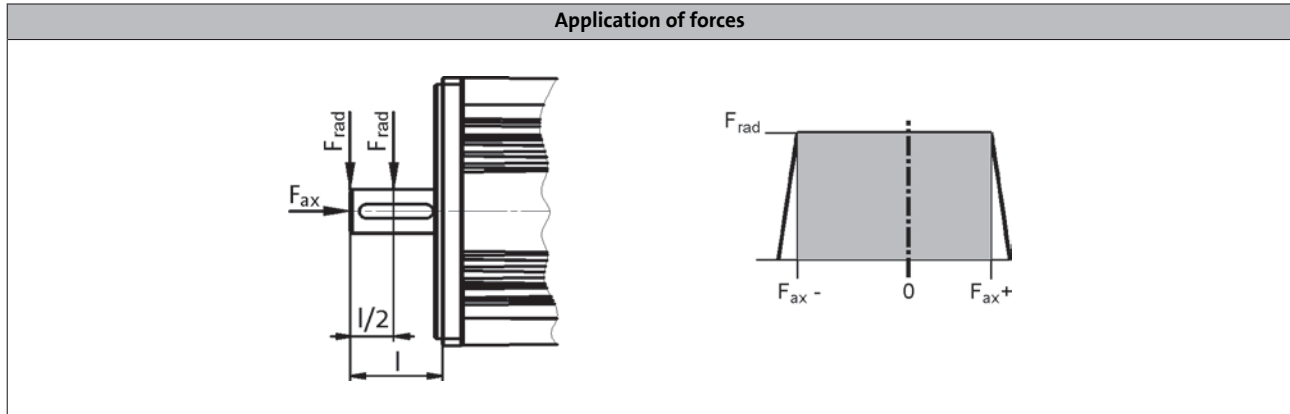

Application of force at l/2

	Bearing service life L_{10}														
	5000 h			10000 h			20000 h			30000 h			50000 h		
	F_{rad}	$F_{ax,-}$	$F_{ax,+}$	F_{rad}	$F_{ax,-}$	$F_{ax,+}$	F_{rad}	$F_{ax,-}$	$F_{ax,+}$	F_{rad}	$F_{ax,-}$	$F_{ax,+}$	F_{rad}	$F_{ax,-}$	$F_{ax,+}$
	[N]	[N]	[N]	[N]	[N]	[N]	[N]	[N]	[N]	[N]	[N]	[N]	[N]	[N]	[N]
MCA10	630	-130	320	500	-60	250	400	-30	210	330	-10	190	230	0	200
MCA13	850	-110	570	700	-10	450	470	0	450		0	450			
MCA14	1000	-140	500	780	-60	420	550	-30	380	400	-10	360	250	0	350
MCA17	1380	-180	790	1040	-70	680	660	-40	650	440	-20	630	280		610
MCA19	1880	-50	1530	1080	-30	1510	500	-100	1490	160	0	1470			
MCA20	3400	-1330	690	2500	-1020	380	1950	-780	140	1700	-690	40			
MCA21	3200	-260	1740	2360	-70	1550	1470	-20	1504	1030	0	1480			
MCA22	3600	-2370	1700	2800	-1740	1090	2200	-1280	640	1900	-1080	440	1600	-880	240
MCA26	6950	-2500	1580	5400	-1800	880	4300	-1300	380	3700	-1090	160			

5.4

Application of force at l

	Bearing service life L_{10}														
	5000 h			10000 h			20000 h			30000 h			50000 h		
	F_{rad}	$F_{ax,-}$	$F_{ax,+}$	F_{rad}	$F_{ax,-}$	$F_{ax,+}$	F_{rad}	$F_{ax,-}$	$F_{ax,+}$	F_{rad}	$F_{ax,-}$	$F_{ax,+}$	F_{rad}	$F_{ax,-}$	$F_{ax,+}$
	[N]	[N]	[N]	[N]	[N]	[N]	[N]	[N]	[N]	[N]	[N]	[N]	[N]	[N]	[N]
MCA10	590	-130	320	470	-60	250	370	-30	210	310	-10	190	220	0	200
MCA13	780	-110	570	640	-10	450	430	0	450	300	0	450			
MCA14	930	-140	500	710	-60	420	490	-30	380	370	-10	360	230	0	350
MCA17	1270	-180	790	960	-70	680	610	-40	650	400	-20	630	260		610
MCA19	1740	-50	1530	1000	-30	1510	420	-100	1490	140	0	1470			
MCA20	3150	-1170	530	2300	-920	280	1800	-710	70	1400	-650	0			
MCA21	2940	-260	1740	2160	-70	1550	1350	-20	1504	950	0	1480			
MCA22	3500	-2240	1600	2600	-1640	1100	2050	-1200	560	1800	-1020	380	1450	-850	200
MCA26	6400	-2080	1150	5000	-1600	680	4000	-1160	230	3400	-1090	50			

- The values for the bearing service life L_{10} relate to an average speed of 4000 r/min. For MCA20/22/26 the speed is 3000 r/min. Depending on the ambient temperatures, the service life of the bearings is also reduced by the grease lifetime.



Permissible radial and axial forces

- Reinforced bearings

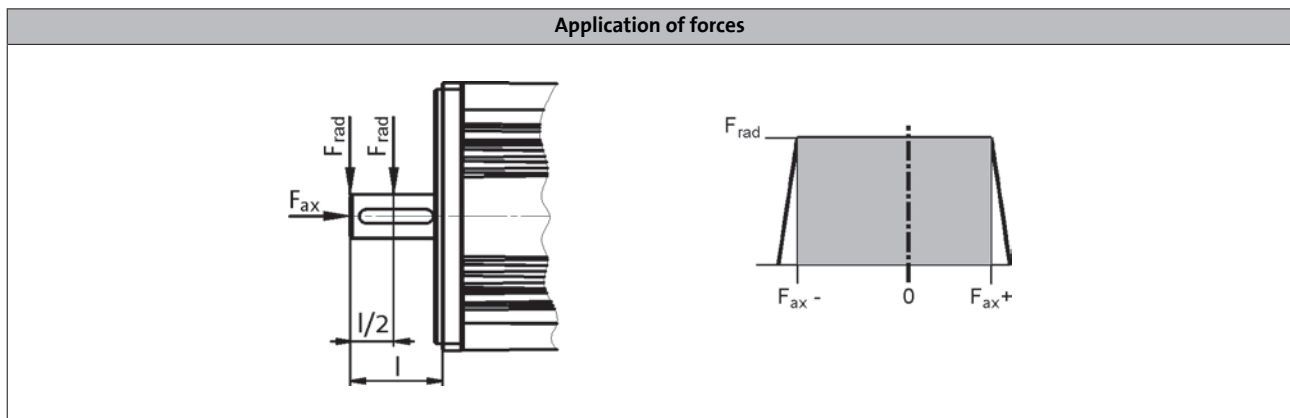

Application of force at l/2

	Bearing service life L_{10}														
	5000 h			10000 h			20000 h			30000 h			50000 h		
	F_{rad}	$F_{ax,-}$	$F_{ax,+}$	F_{rad}	$F_{ax,-}$	$F_{ax,+}$	F_{rad}	$F_{ax,-}$	$F_{ax,+}$	F_{rad}	$F_{ax,-}$	$F_{ax,+}$	F_{rad}	$F_{ax,-}$	$F_{ax,+}$
	[N]	[N]	[N]	[N]	[N]	[N]	[N]	[N]	[N]	[N]	[N]	[N]	[N]	[N]	[N]
MCA20	7100	-970	330	5100	-800	160	3900	-640	0						
MCA22	8500	-1850	1200	7000	-1400	760	5600	-1030	390	4350	-930	290	3200	-800	160
MCA26	10500	-2180	1250	8370	-1530	600	6670	-1130	200	5840	-960	30			

Application of force at l

	Bearing service life L_{10}														
	5000 h			10000 h			20000 h			30000 h			50000 h		
	F_{rad}	$F_{ax,-}$	$F_{ax,+}$	F_{rad}	$F_{ax,-}$	$F_{ax,+}$	F_{rad}	$F_{ax,-}$	$F_{ax,+}$	F_{rad}	$F_{ax,-}$	$F_{ax,+}$	F_{rad}	$F_{ax,-}$	$F_{ax,+}$
	[N]	[N]	[N]	[N]	[N]	[N]	[N]	[N]	[N]	[N]	[N]	[N]	[N]	[N]	[N]
MCA20	6350	-720	80	4100	-680	40	2800	-640	0						
MCA22	7000	-1750	1100	5500	-1300	660	4700	-920	280	3900	-820	180	3000	-700	60
MCA26	9600	-2200	1280	7700	-1280	360	6000	-960	30						

- The values for the bearing service life L_{10} refer to an average speed of 3000 r/min. Depending on the ambient temperatures, the service life of the bearings is also reduced by the grease life-time.

MCA asynchronous servo motors

Technical data



Rated data, non-ventilated

► The data applies to a mains connection voltage of 3 x 400 V.

	n_N [r/min]	M_0 [Nm]	M_N [Nm]	M_{max} [Nm]	P_N [kW]	I_0 [A]	I_N [A]	$U_{N, AC}$ [V]	f_N [Hz]	$J^{1)}$ [kgcm ²]	$\eta_{100\%}$ [%]
MCA10I40	3950	2.30	2.00	10.0	0.80	2.60	2.40	390	140	2.40	0.70
MCA13I41	4050	4.60	4.00	32.0	1.70	4.60	4.40	390	140	8.30	75.0
MCA14L20	2000	8.00	6.70	60.0	1.40	3.90	3.30	390	70	19.2	84.0
MCA14L41	4100	8.00	5.40	60.0	2.30	7.70	5.80	390	140	19.2	78.0
MCA17N23	2300	12.8	10.8	100	2.60	6.00	5.50	390	80	36.0	86.0
MCA17N41	4110	12.8	9.50	100	4.10	12.0	10.2	350	140	36.0	83.0
MCA19S23	2340	22.5	16.3	180	4.00	9.90	8.20	390	80	72.0	90.0
MCA19S42	4150	22.5	12.0	180	5.20	19.7	14.0	330	140	72.0	83.0
MCA21X25	2490	39.0	24.6	300	6.40	15.9	13.5	390	85	180	85.0
MCA21X42	4160	39.0	17.0	300	7.40	31.8	19.8	320	140	180	84.0

	R_1 [Ω]	$R_{UV\ 20\ ^\circ C}$ [Ω]	$R_{UV\ 150\ ^\circ C}$ [Ω]	R_2 [Ω]	$L_{1\sigma}$ [mH]	L [mH]	$L_{2\sigma}$ [mH]	$n_{max}^{2)}$ [r/min]	$m^{1)}$ [kg]
MCA10I40	4.70	9.40	12.7	5.20	9.80	169	10.0	8000	6.40
MCA13I41	1.70	3.40	4.60	1.41	5.40	92.6	4.90		10.4
MCA14L20	3.00	6.00	8.10	3.13	10.0	269	10.0		15.1
MCA14L41	0.75	1.50	2.00	0.78	2.50	65.8	2.50		22.9
MCA17N23	1.52	3.04	4.10	1.37	6.20	176	6.80		
MCA17N41	0.38	0.76	1.00	0.34	1.50	43.4	1.70		
MCA19S23	0.69	1.38	1.90	0.62	3.20	111	3.90		44.7
MCA19S42	0.18	0.35	0.50	0.15	0.80	28.0	1.00		
MCA21X25	0.36	0.72	1.00	0.36	2.30	78.1	2.80		60.0
MCA21X42	0.090	0.18	0.20	0.090	0.60	19.5	0.70		

¹⁾ Without brake.

²⁾ Mechanically permissible maximum speed.

The data in the R_1 , $L_{1\sigma}$, L , R_2' and $L_{2\sigma}'$ columns is based on a single-phase equivalent circuit diagram at 20°C.

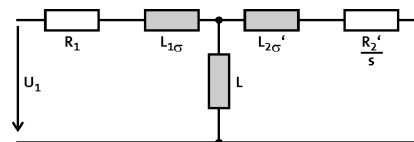

MCA asynchronous servo motors

Technical data



Rated data, IP54 forced ventilated

► The data applies to a mains connection voltage of 3 x 400 V.

	n_N [r/min]	M_0 [Nm]	M_N [Nm]	M_{max} [Nm]	P_N [kW]	I_0 [A]	I_N [A]	$U_{N, AC}$ [V]	f_N [Hz]	$J^{1)}$ [kgcm ²]	$\eta_{100\%}$ [%]
MCA13I34	3410	7.00	6.30	32.0	2.20	6.30	6.00	390	120	8.30	72.0
MCA14L16	1635	13.5	12.0	60.0	2.10	5.30	4.80	390	60	19.2	80.0
MCA14L35	3455	13.5	10.8	60.0	3.90	10.5	9.10	390	120	19.2	79.0
MCA17N17	1680	23.9	21.5	100	3.80	9.10	8.50	390	60	36.0	83.0
MCA17N35	3480	23.9	19.0	100	6.90	18.1	15.8	390	120	36.0	81.0
MCA19S17	1700	40.0	36.3	180	6.40	15.4	13.9	390	60	72.0	82.0
MCA19S35	3510	40.0	36.0	180	13.2	30.8	28.7	390	120	72.0	85.0
MCA21X17	1710	75.0	61.4	300	11.0	25.8	22.5	390	60	180	85.0
MCA21X35	3520	75.0	55.0	300	20.3	49.5	42.5	390	120	180	88.0
MCA22P08...5F□□	760	120	110	500	8.75	23.4	22.1	345	28	487	80.0
MCA22P14...5F□□	1425	120	107	500	16.0	40.5	37.7	350	50	487	87.0
MCA22P17...5F□□	1670	120	106	500	18.5	46.7	42.7	360	58	487	88.0
MCA22P29...5F□□	2935	120	100	500	30.7	80.9	72.1	360	100	487	87.0
MCA26T05...5F□□	550	220	216	1100	12.4	35.4	34.9	350	19	1335	83.0
MCA26T10...5F□□	1030	220	210	1100	22.7	62.9	61.5	350	36	1335	88.0
MCA26T12...5F□□	1200	220	207	1100	26.0	78.4	75.1	350	41	1335	87.0
MCA26T22...5F□□	2235	220	195	1100	45.6	125	113	340	76	1335	92.0

	R_1 [Ω]	$R_{UV\ 20^\circ C}$ [Ω]	$R_{UV\ 150^\circ C}$ [Ω]	R_2 [Ω]	$L_{1\sigma}$ [mH]	L [mH]	$L_{2\sigma}$ [mH]	$n_{max}^{2)}$ [r/min]	$m^{1)}$ [kg]	
MCA13I34	1.70	3.40	4.60	1.41	4.90	76.7	4.40	8000	12.0	
MCA14L16	3.00	6.00	8.10	3.13	9.50	224	9.30		16.9	
MCA14L35	0.75	1.50	2.00	0.78	2.40	56.7	2.30		25.5	
MCA17N17	1.52	3.04	4.10	1.37	5.60	144	6.00		48.2	
MCA17N35	0.38	0.76	1.00	0.34	1.40	36.9	1.50		63.5	
MCA19S17	0.69	1.38	1.90	0.62	2.60	80.9	3.10		6500	105
MCA19S35	0.18	0.35	0.50	0.15	0.70	20.3	0.80			
MCA21X17	0.36	0.72	1.00	0.36	2.10	68.9	2.60			
MCA21X35	0.090	0.18	0.20	0.090	0.50	16.8	0.60			
MCA22P08...5F□□	0.54	1.07	1.62	0.48	3.56	94.9	4.80			
MCA22P14...5F□□		0.36	0.54		3.60	94.2	4.85			
MCA22P17...5F□□	0.13	0.27	0.40	0.12	0.90	23.4	1.21			
MCA22P29...5F□□		0.080	0.12		22.9	1.21				
MCA26T05...5F□□	0.29	0.59	0.89	0.25	2.86	66.8	5.04			
MCA26T10...5F□□		0.20	0.30		2.93	69.2	5.12			
MCA26T12...5F□□	0.080	0.15	0.23	0.062	0.74	18.1	1.29	194		
MCA26T22...5F□□		0.050	0.075		0.78	19.8				

¹⁾ Without brake.

²⁾ Mechanically permissible maximum speed.

The data in the R_1 , $L_{1\sigma}$, L , R_2' and $L_{2\sigma}'$ columns is based on a single-phase equivalent circuit diagram at 20°C.

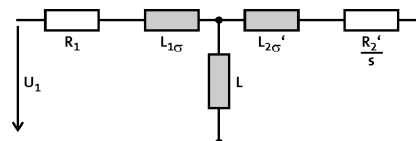

MCA asynchronous servo motors

Technical data



Rated data, IP23s forced ventilated

► The data applies to a mains connection voltage of 3 x 400 V.

	n_N [r/min]	M_0 [Nm]	M_N [Nm]	M_{max} [Nm]	P_N [kW]	I_0 [A]	I_N [A]	$U_{N, AC}$ [V]	f_N [Hz]	$J^{1)}$ [kgcm ²]	$\eta_{100\%}$ [%]
MCA20X14...2F□□	1420	68.0	61.0	250	9.07	26.0	23.0	350	50	171	82.0
MCA20X29...2F□□	2930	68.0	53.5	250	16.4	52.0	42.4	350	100	171	87.0
MCA22P08...2F□□	760	135	120	500	9.55	26.0	23.5	355	28	487	80.0
MCA22P14...2F□□	1425	135	115	500	17.2	45.1	40.0	360	50	487	86.0
MCA22P17...2F□□	1670	135	112	500	19.6	52.1	44.5	360	58	487	88.0
MCA22P29...2F□□	2935	135	110	500	33.8	90.2	77.8	360	100	487	89.0
MCA26T05...2F□□	550	290	280	1100	16.1	44.0	42.4	350	20	1335	81.0
MCA26T10...2F□□	1030	290	260	1100	28.0	78.0	69.6	350	36	1335	87.0
MCA26T12...2F□□	1200	290	255	1100	32.0	101	83.3	350	41	1335	87.0
MCA26T22...2F□□	2235	290	230	1100	53.8	160	127	340	76	1335	92.0

	R_1 [Ω]	$R_{UV\ 20\ ^\circ C}$ [Ω]	$R_{UV\ 150\ ^\circ C}$ [Ω]	R_2 [Ω]	$L_{1\sigma}$ [mH]	L [mH]	$L_{2\sigma}$ [mH]	$n_{max}^{2)}$ [r/min]	$m^{1)}$ [kg]
MCA20X14...2F□□	0.37	0.73	1.10	0.36	2.01	60.2	2.14	6500	64.0
MCA20X29...2F□□	0.090	0.18	0.28	0.090	0.50	14.3	0.54		105
MCA22P08...2F□□	0.54	1.07	1.62	0.48	3.50	91.9	4.74		
MCA22P14...2F□□		0.36	0.54		3.55	90.9	4.79		
MCA22P17...2F□□	0.13	0.27	0.40	0.12	0.90	23.5	1.22	194	
MCA22P29...2F□□		0.080	0.12		22.9	1.21			
MCA26T05...2F□□	0.29	0.59	0.89	0.25	3.11	72.1	5.08		
MCA26T10...2F□□		0.20	0.30		3.17	71.4	5.14		
MCA26T12...2F□□	0.080	0.15	0.23	0.062	0.78	18.6	1.30	194	
MCA26T22...2F□□		0.050	0.077		20.2				

¹⁾ Without brake.

²⁾ Mechanically permissible maximum speed.

The data in the R_1 , $L_{1\sigma}$, L , R_2' and $L_{2\sigma}'$ columns is based on a single-phase equivalent circuit diagram at 20°C.

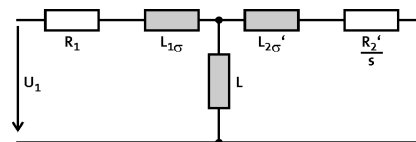

MCA asynchronous servo motors

Technical data



Selection tables, Servo Drives 9400 HighLine

Non-ventilated motors

- The data applies to a mains connection voltage of 3 x 400 V and an inverter switching frequency of 4 kHz.

					E94A□□	E0024	E0034	E0044	E0074	E0094	E0134	E0174	E0244	E0324
					I_N	1.9	3.1	5.0	8.8	11.7	16.3	20.6	29.4	38.4
					$I_{0,max}$	6.0	10.0	16.0	21.0	28.0	39.0	49.5	58.8	76.8
MCA	M_N	n_N	I_N	P_N	I_{max}	6.0	10.0	16.0	21.0	28.0	39.0	49.5	58.8	76.8
10I40	2.0	3950	2.4	0.80	M_0	1.1	2.3							
					M_N	1.0	2.0							
					$M_{0,max}$	6.9	10.0							
					M_{max}	6.9	10.0							
					η_{eto}	-	-							
13I41	4.0	4050	4.4	1.70	M_0			4.6	4.6					
					M_N			4.0	4.0					
					$M_{0,max}$			18.9	20.8					
					M_{max}			18.9	20.8					
					η_{eto}			-	-					
14L20	6.7	2000	3.3	1.40	M_0		5.1	8.0						
					M_N		4.4	6.7						
					$M_{0,max}$		25.0	42.8						
					M_{max}		25.0	42.8						
					η_{eto}		-	-						
14L41	5.4	4100	5.8	2.30	M_0			3.5	8.0	8.0				
					M_N			3.5	5.4	5.4				
					$M_{0,max}$			21.5	27.0	31.3				
					M_{max}			21.5	27.0	31.3				
					η_{eto}			-	-	-				
17N23	10.8	2300	5.5	2.60	M_0			9.5	12.8					
					M_N			9.0	10.8					
					$M_{0,max}$			38.0	50.0					
					M_{max}			38.0	50.0					
					η_{eto}			-	-					
17N41	9.5	4110	10.2	4.10	M_0			7.1	11.5	12.8	12.8			
					M_N			6.7	9.5	9.5	9.5			
					$M_{0,max}$			24.0	33.3	45.8	49.9			
					M_{max}			24.0	33.3	45.8	49.9			
					η_{eto}			-	-	-	-			
19S23	16.3	2340	8.2	4.00	M_0			18.4	22.5	22.5				
					M_N			15.6	16.3	16.3				
					$M_{0,max}$			55.0	73.7	86.0				
					M_{max}			55.0	73.7	86.0				
					η_{eto}			-	-	-				
19S42	12.0	4150	14.0	5.20	M_0					15.0	22.5	22.5		
					M_N					12.0	12.0	12.0		
					$M_{0,max}$					48.8	62.0	70.0		
					M_{max}					48.8	62.0	70.0		
					η_{eto}					-	-	-		
21X25	24.6	2490	13.5	6.40	M_0					21.4	39.0	39.0	39.0	
					M_N					19.6	24.6	24.6	24.6	
					$M_{0,max}$					71.7	96.0	126.0	136.0	
					M_{max}					71.7	96.0	126.0	136.0	
					η_{eto}					-	-	-	-	

- $I...$ [A], $M...$ [Nm], $n...$ [r/min], $P...$ [kW]

MCA asynchronous servo motors

Technical data



Selection tables, Servo Drives 9400 HighLine

Non-ventilated motors

- The data applies to a mains connection voltage of 3 x 400 V and an inverter switching frequency of 4 kHz.

					E94A□□	E0024	E0034	E0044	E0074	E0094	E0134	E0174	E0244	E0324
					I_N	1.9	3.1	5.0	8.8	11.7	16.3	20.6	29.4	38.4
					$I_{0,max}$	6.0	10.0	16.0	21.0	28.0	39.0	49.5	58.8	76.8
MCA	M_N	n_N	I_N	P_N	I_{max}	6.0	10.0	16.0	21.0	28.0	39.0	49.5	58.8	76.8
21X42	17.0	4160	19.8	7.40	M_0								31.3	39.0
					M_N								17.0	17.0
					$M_{0,max}$								71.7	91.0
					M_{max}								71.7	91.0
					η_{eto}									-

- I_N [A], M_N [Nm], n_N [r/min], P_N [kW]

MCA asynchronous servo motors

Technical data



Selection tables, Servo Drives 9400 HighLine

Forced ventilated IP54 motors

- The data applies to a mains connection voltage of 3 x 400 V and an inverter switching frequency of 4 kHz.

					E94A□□	E0044	E0074	E0094	E0134	E0174	E0244	E0324	E0474	E0594	E0864	
					I_N	5.0	8.8	11.7	16.3	20.6	29.4	38.4	47.0	59.0	86.0	
					$I_{0,max}$	16.0	21.0	28.0	39.0	49.5	58.8	76.8	94.0	118.0	172.0	
MCA	M_N	n_N	I_N	P_N	I_{max}	16.0	21.0	28.0	39.0	49.5	58.8	76.8	94.0	118.0	172.0	
13I34	6.3	3410	6.0	2.20	M_0	4.6	7.0	7.0								
					M_N	4.4	6.3	6.3								
					$M_{0,max}$	20.8	26.0	29.2								
					M_{max}	20.8	26.0	29.2								
					η_{eto}	-	-	-								
14L16	12.0	1635	4.8	2.10	M_0	12.0	13.5									
					M_N	12.0	12.0									
					$M_{0,max}$	45.4	52.6									
					M_{max}	45.4	52.6									
					η_{eto}	-	-									
14L35	10.8	3455	9.1	3.90	M_0		10.1	13.5	13.5							
					M_N		9.7	10.8	10.8							
					$M_{0,max}$		32.4	46.0	60.0							
					M_{max}		32.4	46.0	60.0							
					η_{eto}		-	-	-							
17N17	21.5	1680	8.5	3.80	M_0		21.6	23.9	23.9							
					M_N		21.5	21.5	21.5							
					$M_{0,max}$		59.4	81.4	84.5							
					M_{max}		59.4	81.4	84.5							
					η_{eto}		-	-	-							
17N35	19.0	3480	15.8	6.90	M_0				19.4	23.9	23.9					
					M_N				19.0	19.0	19.0					
					$M_{0,max}$				59.2	75.0	90.0					
					M_{max}				59.2	75.0	90.0					
					η_{eto}				-	-	-					
19S17	36.3	1700	13.9	6.40	M_0				40.0	40.0	40.0					
					M_N				36.3	36.3	36.3					
					$M_{0,max}$				105.0	133.0	148.0					
					M_{max}				105.0	133.0	148.0					
					η_{eto}				-	-	-					
19S35	36.0	3510	28.7	13.20	M_0					36.9	40.0	40.0	40.0			
					M_N					36.0	36.0	36.0	36.0			
					$M_{0,max}$					82.0	112.0	132.0	160.0			
					M_{max}					82.0	112.0	132.0	160.0			
					η_{eto}					-	-	-	-			
21X17	61.4	1710	22.5	11.00	M_0				54.4	75.0	75.0	75.0				
					M_N				50.4	61.4	61.4	61.4				
					$M_{0,max}$				134.0	158.0	215.0	246.0				
					M_{max}				134.0	158.0	215.0	246.0				
					η_{eto}				-	-	-	-				
21X35	55.0	3520	42.5	20.30	M_0								63.9	75.0	75.0	
					M_N									55.0	55.0	55.0
					$M_{0,max}$									134.0	167.0	232.0
					M_{max}									134.0	167.0	232.0
					η_{eto}									-	-	-

- $I...$ [A], $M...$ [Nm], $n...$ [r/min], $P...$ [kW]

MCA asynchronous servo motors

Technical data



Selection tables, Servo Drives 9400 HighLine

Forced ventilated IP54 motors

- The data applies to a mains connection voltage of 3 x 400 V and an inverter switching frequency of 8 kHz.

					E94A□□	E0174	E0244	E0324	E0474	E0594	E0864	E1044	E1454	E1724	E2024	E2454	
					I _N	16.5	23.5	32.0	41.0	41.0	73.0	78.0	102.0	120.0	131.0	160.0	
					I _{0,max}	49.5	58.8	76.8	94.0	118.0	172.0	208.0	261.0	310.0	364.0	441.0	
MCA	M _N	n _N	I _N	P _N	I _{max}	49.5	58.8	76.8	94.0	118.0	172.0	208.0	261.0	310.0	364.0	441.0	
22P08- ...5F□□	110.0	760	22.1	8.80	M ₀	64.0	110.0	120.0									
					M _N	64.0	110.0	110.0									
					M _{0,max}	261.0	313.0	402.0									
					M _{max}	261.0	313.0	402.0									
					η _{eto}	-	-	-									
22P14- ...5F□□	107.0	1425	37.7	16.00	M ₀			82.0	120.0	120.0							
					M _N			82.0	107.0	107.0							
					M _{0,max}			242.0	300.0	372.0							
					M _{max}			242.0	300.0	372.0							
					η _{eto}			-	-	-							
22P17- ...5F□□	105.0	1670	42.7	18.50	M ₀					99.0	120.0						
					M _N					99.0	106.0						
					M _{0,max}					325.0	463.0						
					M _{max}					325.0	463.0						
					η _{eto}					-	-						
22P29- ...5F□□	100.0	2935	72.1	30.70	M ₀							110.0	120.0	120.0			
					M _N							100.0	100.0	100.0			
					M _{0,max}							335.0	416.0	465.0			
					M _{max}							335.0	416.0	465.0			
					η _{eto}							-	-	-			
26T05- ...5F□□	216.0	550	34.9	12.40	M ₀			191.0	220.0	220.0	220.0						
					M _N			191.0	216.0	216.0	216.0						
					M _{0,max}			531.0	665.0	826.0	1010.0						
					M _{max}			531.0	665.0	826.0	1010.0						
					η _{eto}			-	-	-	-						
26T10- ...5F□□	210.0	1030	61.5	22.70	M ₀					77.0	220.0	220.0	220.0				
					M _N					77.0	210.0	210.0	210.0				
					M _{0,max}					472.0	713.0	855.0	1044.0				
					M _{max}					472.0	713.0	855.0	1044.0				
					η _{eto}					-	-	-	-				
26T12- ...5F□□	207.0	1200	75.1	26.00	M ₀						204.0	219.0	220.0	220.0			
					M _N						204.0	207.0	207.0	207.0			
					M _{0,max}						502.0	609.0	739.0	819.0			
					M _{max}						502.0	609.0	739.0	819.0			
					η _{eto}						-	-	-	-			
26T22- ...5F□□	195.0	2235	112.9	45.60	M ₀								154.0	211.0	220.0	220.0	
					M _N									154.0	195.0	195.0	195.0
					M _{0,max}									523.0	611.0	711.0	843.0
					M _{max}									523.0	611.0	711.0	843.0
					η _{eto}									-	-	-	-

5.4

- I... [A], M... [Nm], n... [r/min], P... [kW]
- If the motors are operated at a lower switching frequency, please contact your Lenze sales office!
- When operating at 4 kHz, the motor generates just 95 % of its rated torque with increased noise emissions.

MCA asynchronous servo motors

Technical data



Selection tables, Servo Drives 9400 HighLine

Forced ventilated IP23s motors

- The data applies to a mains connection voltage of 3 x 400 V and an inverter switching frequency of 8 kHz.

					E94A□□	E0174	E0244	E0324	E0474	E0594	E0864	E1044	E1454	E1724	E2024	E2454	E2924
					I _N	16.5	23.5	32.0	41.0	41.0	73.0	78.0	102.0	120.0	131.0	160.0	191.0
					I _{0,max}	49.5	58.8	76.8	94.0	118.0	172.0	208.0	261.0	310.0	364.0	441.0	526.0
MCA	M _N	n _N	I _N	P _N	I _{max}	49.5	58.8	76.8	94.0	118.0	172.0	208.0	261.0	310.0	364.0	441.0	526.0
20X14-...2F□□	61.0	1420	23.0	9.10	M ₀	32.5	66.0										
					M _N	32.5	61.0										
					M _{0,max}	154.2	190.0										
					M _{max}	154.2	190.0										
					η _{eto}	-	-										
20X29-...2F□□	53.5	2930	42.4	16.40	M ₀			28.0	51.6	51.6							
					M _N			28.0	51.6	51.6							
					M _{0,max}			116.0	148.2	192.8							
					M _{max}			116.0	148.2	192.8							
					η _{eto}			-	-	-							
22P08-...2F□□	120.0	760	23.5	9.60	M ₀		120.0	135.0									
					M _N		120.0	120.0									
					M _{0,max}		313.0	402.0									
					M _{max}		313.0	402.0									
					η _{eto}		-	-									
22P14-...2F□□	115.0	1425	40.0	17.20	M ₀				118.0	118.0							
					M _N				115.0	115.0							
					M _{0,max}				300.0	372.0							
					M _{max}				300.0	372.0							
					η _{eto}				-	-							
22P17-...2F□□	112.0	1670	44.5	19.60	M ₀					99.0	135.0						
					M _N					99.0	112.0						
					M _{0,max}					325.0	463.0						
					M _{max}					325.0	463.0						
					η _{eto}					-	-						
22P29-...2F□□	110.0	2935	77.8	33.80	M ₀							110.0	135.0	135.0			
					M _N							110.0	110.0	110.0			
					M _{0,max}							335.0	416.0	486.0			
					M _{max}							335.0	416.0	486.0			
					η _{eto}							-	-	-			
26T05-...2F□□	280.0	550	42.4	16.10	M ₀				268.0	268.0	290.0						
					M _N				268.0	268.0	280.0						
					M _{0,max}				665.0	826.0	1100.0						
					M _{max}				665.0	826.0	1100.0						
					η _{eto}				-	-	-						
26T10-...2F□□	260.0	1030	69.6	28.00	M ₀						270.0	290.0	290.0				
					M _N						260.0	260.0	260.0				
					M _{0,max}						713.0	855.0	1044.0				
					M _{max}						713.0	855.0	1044.0				
					η _{eto}						-	-	-				

- I... [A], M... [Nm], n... [r/min], P... [kW]
- If the motors are operated at a lower switching frequency, please contact your Lenze sales office!
- When operating at 4 kHz, the motor generates just 95 % of its rated torque with increased noise emissions.

MCA asynchronous servo motors

Technical data



Selection tables, Servo Drives 9400 HighLine

Forced ventilated IP23s motors

- ▶ The data applies to a mains connection voltage of 3 x 400 V and an inverter switching frequency of 8 kHz.

					E94A□□	E0174	E0244	E0324	E0474	E0594	E0864	E1044	E1454	E1724	E2024	E2454	E2924	
					I_N	16.5	23.5	32.0	41.0	41.0	73.0	78.0	102.0	120.0	131.0	160.0	191.0	
					$I_{0,max}$	49.5	58.8	76.8	94.0	118.0	172.0	208.0	261.0	310.0	364.0	441.0	526.0	
MCA	M_N	n_N	I_N	P_N	I_{max}	49.5	58.8	76.8	94.0	118.0	172.0	208.0	261.0	310.0	364.0	441.0	526.0	
26T12- ...2F□□	255.0	1200	83.3	32.00	M_0						204.0	219.0	290.0	290.0				
					M_N						204.0	219.0	255.0	255.0	255.0			
					$M_{0,max}$						502.0	609.0	739.0	840.0	896.0			
					M_{max}						502.0	609.0	739.0	840.0	896.0			
					η_{eto}											-	-	-
26T22- ...2F□□	230.0	2235	126.7	53.80	M_0									211.0	242.0	290.0	290.0	
					M_N									211.0	230.0	230.0	230.0	
					$M_{0,max}$									611.0	711.0	843.0	1001.0	
					M_{max}									611.0	711.0	843.0	1001.0	
					η_{eto}													-

- ▶ I... [A], M... [Nm], n... [r/min], P... [kW]
- ▶ If the motors are operated at a lower switching frequency, please contact your Lenze sales office!
- ▶ When operating at 4 kHz, the motor generates just 95 % of its rated torque with increased noise emissions.

MCA asynchronous servo motors

Technical data



MCA asynchronous servo motors

Technical data



Selection tables, Inverter Drives 8400 TopLine

Non-ventilated motors

- The data applies to a mains connection voltage of 3 x 400 V and an inverter switching frequency of 8 kHz.

					E84AVTC	□5514	□7514	□1124	□1524	□2224	□3024	□4024	□5524	□7524	□1134	□1534	□1834				
					I_N	1.8	2.4	3.2	3.9	5.9	7.3	9.5	13.0	16.5	23.5	32.0	39.0				
					$I_{0,max}$	2.7	3.6	4.8	5.9	8.4	11.0	14.3	19.5	26.4	32.9	43.2	60.0				
MCA	M_N	n_N	I_N	P_N	I_{max}	3.6	4.8	6.4	7.8	11.8	14.6	19.0	26.0	33.0	47.0	64.0	78.0				
10I40	2.0	3950	2.4	0.80	M_0	-	2.3	2.3	2.3	2.3											
					M_N	-	1.9	1.9	1.9	1.9											
					$M_{0,max}$	4.2	5.8	8.0	9.8	10.0											
					M_{max}	4.2	5.8	8.0	9.8	10.0											
					η_{eto}	-	-	-	-	-											
13I41	4.0	4050	4.4	1.70	M_0			-	-	4.6	4.6	4.6									
					M_N			-	-	4.0	4.0	4.0									
					$M_{0,max}$			7.6	9.6	14.3	18.9	22.9									
					M_{max}			7.6	9.6	14.3	18.9	22.9									
					η_{eto}			-	-	-	-	-									
14L20	6.7	2000	3.3	1.40	M_0		-	-	8.0	8.0	8.0										
					M_N		-	-	6.7	6.7	6.7										
					$M_{0,max}$		11.6	16.2	20.1	29.4	34.7										
					M_{max}		11.6	16.2	20.1	29.4	34.7										
					η_{eto}		-	-	-	-	-										
14L41	5.4	4100	5.8	2.30	M_0				-	8.0	8.0	8.0									
					M_N				-	5.4	5.4	5.4									
					$M_{0,max}$				14.1	19.0	25.1	31.0									
					M_{max}				14.1	19.0	25.1	31.0									
					η_{eto}				-	-	-	-									
17N23	10.8	2300	5.5	2.60	M_0			-	12.8	12.8	12.8	12.8									
					M_N			-	10.8	10.8	10.8	10.8									
					$M_{0,max}$			17.1	25.3	33.3	43.8	51.1									
					M_{max}			17.1	25.3	33.3	43.8	51.1									
					η_{eto}			-	-	-	-	-									
17N41	9.5	4110	10.2	4.10	M_0					-	-	12.8	12.8	12.8							
					M_N					-	-	9.5	9.5	9.5							
					$M_{0,max}$					16.5	22.3	31.1	39.9	49.5							
					M_{max}					16.5	22.3	31.1	39.9	49.5							
					η_{eto}					-	-	-	-	-							
19S23	16.3	2340	8.2	4.00	M_0						-	22.5	22.5	22.5							
					M_N					-	16.3	16.3	16.3								
					$M_{0,max}$					32.8	43.6	60.9	77.5								
					M_{max}					32.8	43.7	61.0	77.5								
					η_{eto}					-	-	-	-								
19S42	12.0	4150	14.0	5.20	M_0								-	22.5	22.5	22.5					
					M_N								-	12.0	12.0	12.0					
					$M_{0,max}$								28.5	37.0	53.7	64.7					
					M_{max}								28.5	37.0	53.8	64.7					
					η_{eto}								-	-	-	-					
21X25	24.6	2490	13.5	6.40	M_0								-	39.0	39.0	39.0					
					M_N								-	24.5	24.5	24.5					
					$M_{0,max}$								33.6	46.7	59.3	85.9	97.3				
					M_{max}								33.6	46.7	59.3	85.9	97.6				
					η_{eto}								-	-	-	-					

- I... [A], M... [Nm], n... [r/min], P... [kW]

MCA asynchronous servo motors

Technical data



Selection tables, Inverter Drives 8400 TopLine

Non-ventilated motors

- The data applies to a mains connection voltage of 3 x 400 V and an inverter switching frequency of 8 kHz.

					E84AVTC	□5514	□7514	□1124	□1524	□2224	□3024	□4024	□5524	□7524	□1134	□1534	□1834	
					I_N	1.8	2.4	3.2	3.9	5.9	7.3	9.5	13.0	16.5	23.5	32.0	39.0	
					$I_{0,max}$	2.7	3.6	4.8	5.9	8.4	11.0	14.3	19.5	26.4	32.9	43.2	60.0	
MCA	M_N	n_N	I_N	P_N	I_{max}	3.6	4.8	6.4	7.8	11.8	14.6	19.0	26.0	33.0	47.0	64.0	78.0	
21X42	17.0	4160	19.8	7.40	M_0									-	39.0	39.0	39.0	
					M_N									-	17.0	17.0	17.0	
					$M_{0,max}$										35.3	52.2	72.1	88.5
					M_{max}										35.3	52.2	72.1	88.5
					η_{eto}													-

- I_N [A], M_N [Nm], n_N [r/min], P_N [kW]

MCA asynchronous servo motors

Technical data



Selection tables, Inverter Drives 8400 TopLine

Forced ventilated IP54 motors

- The data applies to a mains connection voltage of 3 x 400 V and an inverter switching frequency of 8 kHz.

					E84AVTC	□1524	□2224	□3024	□4024	□5524	□7524
					I_N	3.9	5.9	7.3	9.5	13.0	16.5
					$I_{0,max}$	5.9	8.4	11.0	14.3	19.5	26.4
MCA	M_N	n_N	I_N	P_N	I_{max}	7.8	11.8	14.6	19.0	26.0	33.0
13I34	6.3	3410	6.0	2.20	M_0	-	-	7.0	7.0	7.0	-
					M_N	-	-	6.2	6.2	6.2	-
					$M_{0,max}$	-	16.0	21.4	28.2	32.0	-
					M_{max}	-	16.0	21.4	28.2	32.0	-
					η_{eto}	-	-	-	-	-	-
14L16	12.0	1635	4.8	2.10	M_0	-	13.5	13.5	13.5	-	-
					M_N	-	12.3	12.3	12.3	-	-
					$M_{0,max}$	23.4	34.7	45.5	50.8	-	-
					M_{max}	23.4	34.7	45.5	50.8	-	-
					η_{eto}	-	-	-	-	-	-
14L35	10.8	3455	9.1	3.90	M_0	-	-	-	13.5	13.5	13.5
					M_N	-	-	-	10.8	10.8	10.8
					$M_{0,max}$	-	-	21.1	28.4	39.8	51.1
					M_{max}	-	-	21.1	28.4	39.8	51.1
					η_{eto}	-	-	-	-	-	-
17N17	21.5	1680	8.5	3.80	M_0	-	-	-	23.9	23.9	23.9
					M_N	-	-	-	21.6	21.6	21.6
					$M_{0,max}$	-	-	42.1	55.9	77.5	93.3
					M_{max}	-	-	42.2	56.0	77.5	93.3
					η_{eto}	-	-	-	-	-	-
17N35	19.0	3480	15.8	6.90	M_0	-	-	-	-	-	23.9
					M_N	-	-	-	-	-	18.9
					$M_{0,max}$	-	-	-	-	38.0	49.5
					M_{max}	-	-	-	-	38.0	49.5
					η_{eto}	-	-	-	-	-	-
19S17	36.3	1700	13.9	6.40	M_0	-	-	-	-	-	40.0
					M_N	-	-	-	-	-	36.0
					$M_{0,max}$	-	-	-	-	71.6	94.7
					M_{max}	-	-	-	-	71.6	94.7
					η_{eto}	-	-	-	-	-	-
19S35	36.0	3510	28.7	13.20	M_0	-	-	-	-	-	-
					M_N	-	-	-	-	-	-
					$M_{0,max}$	-	-	-	-	-	-
					M_{max}	-	-	-	-	-	-
					η_{eto}	-	-	-	-	-	-
21X17	61.4	1710	22.5	11.00	M_0	-	-	-	-	-	-
					M_N	-	-	-	-	-	-
					$M_{0,max}$	-	-	-	-	-	99.0
					M_{max}	-	-	-	-	-	99.0
					η_{eto}	-	-	-	-	-	-
21X35	55.0	3520	42.5	20.30	M_0	-	-	-	-	-	-
					M_N	-	-	-	-	-	-
					$M_{0,max}$	-	-	-	-	-	-
					M_{max}	-	-	-	-	-	-
					η_{eto}	-	-	-	-	-	-

- I... [A], M... [Nm], n... [r/min], P... [kW]

MCA asynchronous servo motors

Technical data



Selection tables, Inverter Drives 8400 TopLine

Forced ventilated IP54 motors

- The data applies to a mains connection voltage of 3 x 400 V and an inverter switching frequency of 8 kHz.

□1134	□1534	□1834	□2234	□3034	□3734	□4534	E84AVTC							
23.5	32.0	39.0	47.0	61.0	76.0	89.0	I_N	2.20	6.0	3410	6.3	13134		
32.9	43.2	60.0	70.5	91.5	114.0	133.5	$I_{0,max}$							
47.0	64.0	78.0	94.0	122.0	152.0	178.0	I_{max}							
							M_0							
							M_N							
							$M_{0,max}$	2.10	4.8	1635	12.0	14L16		
							M_{max}							
							n_{eto}							
							M_0							
							M_N							
13.5							$M_{0,max}$	3.90	9.1	3455	10.8	14L35		
10.8							M_{max}							
56.5							n_{eto}							
56.6							M_0							
-							M_N							
							$M_{0,max}$	3.80	8.5	1680	21.5	17N17		
							M_{max}							
							n_{eto}							
							M_0							
							M_N							
23.9	23.9						$M_{0,max}$	6.90	15.8	3480	19.0	17N35		
18.9	18.9						M_{max}							
72.5	97.8						n_{eto}							
72.5	97.8						M_0							
-	-						M_N							
40.0	40.0						$M_{0,max}$	6.40	13.9	1700	36.3	19S17		
36.0	36.0						M_{max}							
138.9	165.2						n_{eto}							
139.0	165.3						M_0							
-	-						M_N							
-	40.0	40.0	40.0	40.0			$M_{0,max}$	13.20	28.7	3510	36.0	19S35		
-	35.9	35.9	35.9	35.9			M_{max}							
55.1	78.8	97.8	112.8	146.2			n_{eto}							
55.1	78.8	97.8	112.9	146.2			M_0							
-	-	-	-	-			M_N							
75.0	75.0	75.0	75.0				$M_{0,max}$	11.00	22.5	1710	61.4	21X17		
61.4	61.4	61.4	61.4				M_{max}							
143.7	198.5	242.2	277.2				n_{eto}							
144.0	198.7	242.3	277.2				M_0							
-	-	-	-				M_N							
			75.0	75.0	75.0	75.0	$M_{0,max}$	20.30	42.5	3520	55.0	21X35		
			55.1	55.1	55.1	55.1	M_{max}							
	97.5	120.6	138.5	177.5	216.7	267.8	n_{eto}							
	97.5	120.6	138.6	178.0	217.5	269.8	M_0							
	-	-	-	-	-	-	M_N							

- $I...$ [A], $M...$ [Nm], $n...$ [r/min], $P...$ [kW]

MCA asynchronous servo motors

Technical data



Selection tables, Inverter Drives 8400 TopLine

Forced ventilated IP54 motors

- The data applies to a mains connection voltage of 3 x 400 V and an inverter switching frequency of 8 kHz.

					E84AVTC	□7524	□1134	□1534	□1834	□2234	□3034	□3734	□4534	
					I_N	16.5	23.5	32.0	39.0	47.0	61.0	76.0	89.0	
					$I_{0,max}$	26.4	32.9	43.2	60.0	70.5	91.5	114.0	133.5	
MCA	M_N	n_N	I_N	P_N	I_{max}	33.0	47.0	64.0	78.0	94.0	122.0	152.0	178.0	
22P08- ...5F□□	110.0	760	22.1	8.80	M_0	-	120.0	120.0	120.0	120.0				
					M_N	-	110.6	110.6	110.6	110.6				
					$M_{0,max}$	157.8	233.4	323.3	396.6	394.3				
					M_{max}	157.8	233.5	323.3	396.6	394.3				
					η_{eto}	-	-	-	-	-				
22P14- ...5F□□	107.0	1425	37.7	16.00	M_0			-	120.0	120.0	120.0	120.0	120.0	
					M_N				-	107.2	107.2	107.2	107.2	107.2
					$M_{0,max}$				186.5	232.5	268.8	345.7	422.7	458.8
					M_{max}				186.7	232.7	269.0	346.3	423.7	460.9
					η_{eto}				-	-	-	-	-	-
22P17- ...5F□□	105.0	1670	42.7	18.50	M_0				-	120.0	120.0	120.0	120.0	
					M_N				-	-	105.8	105.8	105.8	105.8
					$M_{0,max}$				162.7	204.2	236.9	307.8	374.9	461.2
					M_{max}				162.7	204.2	237.1	308.3	377.0	462.4
					η_{eto}				-	-	-	-	-	-
22P29- ...5F□□	100.0	2935	72.1	30.70	M_0						-	120.0	120.0	
					M_N							-	99.9	99.9
					$M_{0,max}$							180.5	224.5	270.5
					M_{max}							180.8	226.0	271.4
					η_{eto}							-	-	-

5.4

- $I...$ [A], $M...$ [Nm], $n...$ [r/min], $P...$ [kW]
- If the motors are operated at a lower switching frequency, please contact your Lenze sales office!

MCA asynchronous servo motors

Technical data



Selection tables, Inverter Drives 8400 TopLine

Forced ventilated IP23s motors

- The data applies to a mains connection voltage of 3 x 400 V and an inverter switching frequency of 8 kHz.

					E84AVTC	□7524	□1134	□1534	□1834	□2234	□3034	□3734	□4534
					I_N	16.5	23.5	32.0	39.0	47.0	61.0	76.0	89.0
					$I_{0,max}$	26.4	32.9	43.2	60.0	70.5	91.5	114.0	133.5
MCA	M_N	n_N	I_N	P_N	I_{max}	33.0	47.0	64.0	78.0	94.0	122.0	152.0	178.0
20X14- ...2F□□	61.0	1420	23.0	9.10	M_0	-	67.0	68.0	68.0	68.0			
					M_N	-	61.2	61.2	61.2	61.2			
					$M_{0,max}$	94.8	139.9	192.6	235.5	250.0			
					M_{max}	94.9	139.9	192.8	235.7	250.0			
					η_{eto}	-	-	-	-	-			
20X29- ...2F□□	53.5	2930	42.4	16.40	M_0			-	-	57.0	68.0	68.0	68.0
					M_N			-	-	53.4	53.4	53.4	53.4
					$M_{0,max}$			96.8	121.2	140.3	182.5	222.1	250.0
					M_{max}			96.8	121.2	140.4	182.6	223.0	250.0
					η_{eto}			-	-	-	-	-	-
22P08- ...2F□□	120.0	760	23.5	9.60	M_0	-	135.0	135.0	135.0	135.0			
					M_N	-	120.6	120.6	120.6	120.6			
					$M_{0,max}$	157.8	234.2	325.4	401.4	400.9			
					M_{max}	157.8	234.8	325.8	401.4	400.9			
					η_{eto}	-	-	-	-	-			
22P14- ...2F□□	115.0	1425	40.0	17.20	M_0			-	-	135.0	135.0	135.0	135.0
					M_N			-	-	115.3	115.3	115.3	115.3
					$M_{0,max}$			188.4	235.1	270.8	350.2	425.8	493.6
					M_{max}			188.7	235.1	271.0	350.3	428.1	496.1
					η_{eto}			-	-	-	-	-	-
22P17- ...2F□□	112.0	1670	44.5	19.60	M_0			-	-	135.0	135.0	135.0	135.0
					M_N			-	-	112.1	112.1	112.1	112.1
					$M_{0,max}$			163.1	204.6	237.9	309.7	376.9	463.1
					M_{max}			163.1	204.6	238.2	310.6	379.0	465.2
					η_{eto}			-	-	-	-	-	-
22P29- ...2F□□	110.0	2935	77.8	33.80	M_0					-	-	-	135.0
					M_N					-	-	-	110.0
					$M_{0,max}$					180.0	224.4	268.2	
					M_{max}					180.7	225.0	269.4	
					η_{eto}					-	-	-	

- $I...$ [A], $M...$ [Nm], $n...$ [r/min], $P...$ [kW]
- If the motors are operated at a lower switching frequency, please contact your Lenze sales office!

MCA asynchronous servo motors

Technical data



Selection tables, Servo Drives ECS

Non-ventilated motors

- The data applies to a mains connection voltage of 3 x 400 V and an inverter switching frequency of 4 kHz.

					ECS□□	008C□B	016C□B	032C□B	048C□B	064C□B
					I_N	4.0	8.0	12.7	17.0	20.0
					$I_{0,max}$	4.6	9.1	18.1	27.2	36.3
MCA	M_N	n_N	I_N	P_N	I_{max}	8.0	16.0	32.0	48.0	64.0
10I40	2.0	3950	2.4	0.80	M_0	2.3				
					M_N	2.0				
					$M_{0,max}$	5.6				
					M_{max}	8.1				
					η_{eto}	-				
13I41	4.0	4050	4.4	1.70	M_0	3.0	4.6			
					M_N	3.0	4.0			
					$M_{0,max}$	4.3	11.0			
					M_{max}	9.4	18.2			
					η_{eto}	-	-			
14L20	6.7	2000	3.3	1.40	M_0	8.0	8.0			
					M_N	6.7	6.7			
					$M_{0,max}$	10.7	25.3			
					M_{max}	21.6	42.8			
					η_{eto}	-	-			
14L41	5.4	4100	5.8	2.30	M_0		8.0	8.0		
					M_N		5.4	5.4		
					$M_{0,max}$		11.0	24.0		
					M_{max}		20.7	29.1		
					η_{eto}		-	-		
17N23	10.8	2300	5.5	2.60	M_0		12.8	12.8		
					M_N		10.8	10.8		
					$M_{0,max}$		20.5	43.5		
					M_{max}		40.2	63.7		
					η_{eto}		-	-		
17N41	9.5	4110	10.2	4.10	M_0		6.1	12.8	12.8	
					M_N		6.1	9.5	9.5	
					$M_{0,max}$		7.8	21.5	33.5	
					M_{max}		17.4	29.6	57.7	
					η_{eto}		-	-	-	
19S23	16.3	2340	8.2	4.00	M_0		15.1	22.5		
					M_N		15.1	16.3		
					$M_{0,max}$		18.7	43.5		
					M_{max}		38.5	67.9		
					η_{eto}		-	-		
19S42	12.0	4150	14.0	5.20	M_0			9.8	16.7	
					M_N			9.8	12.0	
					$M_{0,max}$			18.4	31.9	
					M_{max}			29.9	58.2	
					η_{eto}			-	-	
21X25	24.6	2490	13.5	6.40	M_0			21.0	39.0	
					M_N			21.0	24.6	
					$M_{0,max}$			41.0	64.5	
					M_{max}			64.4	120.5	
					η_{eto}			-	-	

- $I...$ [A], $M...$ [Nm], $n...$ [r/min], $P...$ [kW]

MCA asynchronous servo motors

Technical data



Selection tables, Servo Drives ECS

Non-ventilated motors

- The data applies to a mains connection voltage of 3 x 400 V and an inverter switching frequency of 4 kHz.

					ECS□□	008C□B	016C□B	032C□B	048C□B	064C□B
					I_N	4.0	8.0	12.7	17.0	20.0
					$I_{0,max}$	4.6	9.1	18.1	27.2	36.3
MCA	M_N	n_N	I_N	P_N	I_{max}	8.0	16.0	32.0	48.0	64.0
21X42	17.0	4160	19.8	7.40	M_0				13.0	17.0
					M_N				13.0	17.0
					$M_{0,max}$				30.0	45.0
					M_{max}				59.4	83.0
					η_{eto}				-	-

- $I...$ [A], $M...$ [Nm], $n...$ [r/min], $P...$ [kW]

MCA asynchronous servo motors

Technical data



Selection tables, Servo Drives ECS

Forced ventilated IP54 motors

- The data applies to a mains connection voltage of 3 x 400 V and an inverter switching frequency of 4 kHz.

					ECS□□	008C□B	016C□B	032C□B	048C□B	064C□B
					I_N	4.0	8.0	12.7	17.0	20.0
					$I_{0,max}$	4.6	9.1	18.1	27.2	36.3
MCA	M_N	n_N	I_N	P_N	I_{max}	8.0	16.0	32.0	48.0	64.0
13I34	6.3	3410	6.0	2.20	M_0		7.0			
					M_N		6.3			
					$M_{0,max}$		10.7			
					M_{max}		20.8			
					η_{eto}		-			
14L16	12.0	1635	4.8	2.10	M_0	8.9	13.5			
					M_N	8.9	12.0			
					$M_{0,max}$	11.5	25.4			
					M_{max}	21.6	46.7			
					η_{eto}	-	-			
14L35	10.8	3455	9.1	3.90	M_0		8.3	13.5	13.5	
					M_N		8.3	10.8	10.8	
					$M_{0,max}$		11.0	27.0	41.0	
					M_{max}		22.2	42.0	60.0	
					η_{eto}		-	-	-	
17N17	21.5	1680	8.5	3.80	M_0		19.5	23.9		
					M_N		19.5	21.5		
					$M_{0,max}$		23.0	53.0		
					M_{max}		44.8	80.0		
					η_{eto}		-	-		
17N35	19.0	3480	15.8	6.90	M_0			12.7	23.0	
					M_N			12.7	19.0	
					$M_{0,max}$			23.0	37.5	
					M_{max}			37.7	64.4	
					η_{eto}			-	-	
19S17	36.3	1700	13.9	6.40	M_0			28.3	40.0	40.0
					M_N			28.3	36.3	36.3
					$M_{0,max}$			46.5	72.0	98.0
					M_{max}			75.4	130.8	158.9
					η_{eto}			-	-	-
21X17	61.4	1710	22.5	11.00	M_0					52.5
					M_N					52.5
					$M_{0,max}$					107.0
					M_{max}					190.0
					η_{eto}					-

- I... [A], M... [Nm], n... [r/min], P... [kW]

MCA asynchronous servo motors

Technical data



Selection tables, Servo Inverter 9300

Non-ventilated motors

- The data applies to a mains connection voltage of 3 x 400 V and an inverter switching frequency of 8 kHz.

					EVS	9322-E□	9323-E□	9324-E□	9325-E□	9326-E□	9327-E□	9328-E□	9329-E□
					I_N	2.5	3.9	7.0	13.0	23.5	32.0	47.0	59.0
					$I_{0,max}$	3.8	5.9	10.5	19.5	23.5	32.0	47.0	52.0
MCA	M_N	n_N	I_N	P_N	I_{max}	3.8	5.9	10.5	19.5	35.3	48.0	70.5	88.5
10I40	2.0	3950	2.4	0.80	M_0	2.2	2.3						
					M_N	2.0	2.0						
					$M_{0,max}$	4.4	7.3						
					M_{max}	4.4	7.3						
					η_{eto}	-	-						
13I41	4.0	4050	4.4	1.70	M_0			4.6	4.6				
					M_N			4.0	4.0				
					$M_{0,max}$			12.6	19.5				
					M_{max}			12.6	19.5				
					η_{eto}			-	-				
14L20	6.7	2000	3.3	1.40	M_0		8.0	8.0					
					M_N		6.7	6.7					
					$M_{0,max}$		15.1	29.3					
					M_{max}		15.1	29.3					
					η_{eto}		-	-					
14L41	5.4	4100	5.8	2.30	M_0			7.0	8.0				
					M_N			5.4	5.4				
					$M_{0,max}$			13.2	26.0				
					M_{max}			13.2	26.0				
					η_{eto}			-	-				
17N23	10.8	2300	5.5	2.60	M_0			12.8	12.8				
					M_N			10.8	10.8				
					$M_{0,max}$			24.4	46.2				
					M_{max}			24.4	46.2				
					η_{eto}			-	-				
17N41	9.5	4110	10.2	4.10	M_0				12.8	12.8	12.8		
					M_N				9.5	9.5	9.5		
					$M_{0,max}$				23.4	37.0	54.0		
					M_{max}				23.4	43.7	59.4		
					η_{eto}				-	-	-		
19S23	16.3	2340	8.2	4.00	M_0				22.5	22.5			
					M_N				16.3	16.3			
					$M_{0,max}$				47.2	78.0			
					M_{max}				47.2	88.2			
					η_{eto}				-	-			
19S42	12.0	4150	14.0	5.20	M_0				10.0	22.5	22.5		
					M_N				10.0	12.0	12.0		
					$M_{0,max}$				20.7	33.5	51.0		
					M_{max}				20.7	43.3	60.7		
					η_{eto}				-	-	-		
21X25	24.6	2490	13.5	6.40	M_0				23.7	39.0	39.0		
					M_N				23.7	24.6	24.6		
					$M_{0,max}$				46.2	66.0	84.0		
					M_{max}				46.2	78.0	92.4		
					η_{eto}				-	-	-		

- $I...$ [A], $M...$ [Nm], $n...$ [r/min], $P...$ [kW]

MCA asynchronous servo motors

Technical data



Selection tables, Servo Inverter 9300

Non-ventilated motors

- The data applies to a mains connection voltage of 3 x 400 V and an inverter switching frequency of 8 kHz.

					EVS	9322-E□	9323-E□	9324-E□	9325-E□	9326-E□	9327-E□	9328-E□	9329-E□
					I_N	2.5	3.9	7.0	13.0	23.5	32.0	47.0	59.0
					$I_{0,max}$	3.8	5.9	10.5	19.5	23.5	32.0	47.0	52.0
MCA	M_N	n_N	I_N	P_N	I_{max}	3.8	5.9	10.5	19.5	35.3	48.0	70.5	88.5
21X42	17.0	4160	19.8	7.40	M_0					24.0	39.0	39.0	39.0
					M_N					17.0	17.0	17.0	17.0
					$M_{0,max}$					24.0	47.0	84.0	94.0
					M_{max}					43.9	63.3	96.8	123.0
					η_{eto}					-	-	-	-

- I_N [A], M_N [Nm], n_N [r/min], P_N [kW]

MCA asynchronous servo motors

Technical data



Selection tables, Servo Inverter 9300

Forced ventilated IP54 motors

- The data applies to a mains connection voltage of 3 x 400 V and an inverter switching frequency of 8 kHz.

					EVS	9324-E□	9325-E□	9326-E□	9327-E□	9328-E□	9329-E□	9330-E□	9331-E□
					I_N	7.0	13.0	23.5	32.0	47.0	59.0	89.0	110.0
					$I_{0,max}$	10.5	19.5	23.5	32.0	47.0	52.0	80.0	110.0
MCA	M_N	n_N	I_N	P_N	I_{max}	10.5	19.5	35.3	48.0	70.5	88.5	133.5	165.0
13I34	6.3	3410	6.0	2.20	M_0	7.0	7.0						
					M_N	6.3	6.3						
					$M_{0,max}$	13.0	25.0						
					M_{max}	13.0	25.0						
					η_{eto}	-	-						
14L16	12.0	1635	4.8	2.10	M_0	13.5							
					M_N	12.0							
					$M_{0,max}$	29.6							
					M_{max}	29.6							
					η_{eto}	-							
14L35	10.8	3455	9.1	3.90	M_0		13.5	13.5					
					M_N		10.8	10.8					
					$M_{0,max}$		29.3	47.0					
					M_{max}		29.3	53.8					
					η_{eto}		-	-					
17N17	21.5	1680	8.5	3.80	M_0		23.9						
					M_N		21.5						
					$M_{0,max}$		57.2						
					M_{max}		57.2						
					η_{eto}		-						
17N35	19.0	3480	15.8	6.90	M_0			23.9	23.9	23.9			
					M_N			19.0	19.0	19.0			
					$M_{0,max}$			27.5	57.0	89.0			
					M_{max}			50.7	69.2	100.2			
					η_{eto}			-	-	-			
19S17	36.3	1700	13.9	6.40	M_0		34.0	40.0	40.0				
					M_N		34.0	36.3	36.3				
					$M_{0,max}$		50.1	76.0	112.0				
					M_{max}		50.1	95.9	130.8				
					η_{eto}		-	-	-				
19S35	36.0	3510	28.7	13.20	M_0			21.0	39.0	40.0	40.0	40.0	
					M_N			21.0	36.0	36.0	36.0	36.0	
					$M_{0,max}$			21.0	39.0	73.0	80.0	161.5	
					M_{max}			45.7	67.6	104.3	132.9	180.0	
					η_{eto}			-	-	-	-	-	
21X17	61.4	1710	22.5	11.00	M_0			65.5	75.0	75.0	75.0		
					M_N			61.4	61.4	61.4	61.4		
					$M_{0,max}$			65.5	102.0	178.0	200.0		
					M_{max}			104.1	143.3	210.7	257.3		
					η_{eto}			-	-	-	-		
21X35	55.0	3520	42.5	20.30	M_0					68.0	75.0	75.0	75.0
					M_N					55.0	55.0	55.0	55.0
					$M_{0,max}$					68.0	88.0	156.0	219.0
					M_{max}					107.7	135.9	205.0	250.1
					η_{eto}					-	-	-	-

- $I...$ [A], $M...$ [Nm], $n...$ [r/min], $P...$ [kW]

MCA asynchronous servo motors



Technical data

Selection tables, Servo Inverter 9300

Forced ventilated IP54 motors

- The data applies to a mains connection voltage of 3 x 400 V and an inverter switching frequency of 8 kHz.

					EVS	9326-E□	9327-E□	9328-E□	9329-E□	9330-E□	9331-E□	9332-E□
					I_N	23.5	32.0	47.0	59.0	89.0	110.0	145.0
					$I_{0,max}$	23.5	32.0	47.0	52.0	80.0	110.0	126.0
MCA	M_N	n_N	I_N	P_N	I_{max}	35.3	48.0	70.5	88.5	133.5	165.0	217.5
22P08-...5F□□	110.0	760	22.1	8.80	M_0	115.0	120.0	120.0	120.0			
					M_N	108.0	110.0	110.0	110.0			
					$M_{0,max}$	115.0	166.0	242.0	267.0			
					M_{max}	185.0	247.0	338.8	345.8			
					η_{eto}	-	-	-	-			
22P14-...5F□□	107.0	1425	37.7	16.00	M_0			120.0	120.0	120.0		
					M_N			107.0	107.0	107.0		
					$M_{0,max}$			146.0	160.0	264.0		
					M_{max}			230.1	292.9	341.8		
					η_{eto}			-	-	-		
22P17-...5F□□	105.0	1670	42.7	18.50	M_0			120.0	120.0	120.0	120.0	
					M_N			106.0	106.0	106.0	106.0	
					$M_{0,max}$			124.0	140.0	240.0	335.0	
					M_{max}			180.5	227.7	342.1	378.3	
					η_{eto}			-	-	-	-	
22P29-...5F□□	100.0	2935	72.1	30.70	M_0					118.0	120.0	120.0
					M_N					100.0	100.0	100.0
					$M_{0,max}$					122.0	171.0	200.0
					M_{max}					215.6	273.1	355.1
					η_{eto}					-	-	-
26T05-...5F□□	216.0	550	34.9	12.40	M_0		191.0	220.0	220.0	220.0		
					M_N		191.0	216.0	216.0	216.0		
					$M_{0,max}$		191.0	303.0	333.0	615.0		
					M_{max}		313.0	482.0	612.0	751.0		
					η_{eto}			-	-	-		
26T10-...5F□□	210.0	1030	61.5	22.70	M_0				159.0	220.0	220.0	
					M_N				197.0	210.0	210.0	
					$M_{0,max}$				159.0	300.0	440.0	
					M_{max}				343.0	552.0	671.0	
					η_{eto}					-	-	-
26T12-...5F□□	207.0	1200	75.1	26.00	M_0					207.0	220.0	220.0
					M_N					255.0	207.0	207.0
					$M_{0,max}$					258.0	327.0	397.0
					M_{max}					424.0	512.0	663.0
					η_{eto}					-	-	-
26T22-...5F□□	195.0	2235	112.9	45.60	M_0						177.0	220.0
					M_N						177.0	195.0
					$M_{0,max}$						203.0	220.0
					M_{max}						315.0	432.0
					η_{eto}						-	-

- $I...$ [A], $M...$ [Nm], $n...$ [r/min], $P...$ [kW]
- If the motors are operated at a lower switching frequency, please contact your Lenze sales office!

MCA asynchronous servo motors

Technical data



Selection tables, Servo Inverter 9300

Forced ventilated IP23s motors

- The data applies to a mains connection voltage of 3 x 400 V and an inverter switching frequency of 8 kHz.

					EVS	9326-E□	9327-E□	9328-E□	9329-E□	9330-E□	9331-E□	9332-E□
					I _N	23.5	32.0	47.0	59.0	89.0	110.0	145.0
					I _{0,max}	23.5	32.0	47.0	52.0	80.0	110.0	126.0
MCA	M _N	n _N	I _N	P _N	I _{max}	35.3	48.0	70.5	88.5	133.5	165.0	217.5
20X14-...2F□□	61.0	1420	23.0	9.10	M ₀	61.0	68.0	68.0				
					M _N	61.0	61.0	61.0				
					M _{0,max}	61.0	93.0	153.0				
					M _{max}	109.3	156.7	232.1				
					η _{eto}	-	-	-				
20X29-...2F□□	53.5	2930	42.4	16.40	M ₀		28.0	66.3	68.0	68.0		
					M _N		28.0	53.5	53.5	53.5		
					M _{0,max}		28.0	66.3	72.0	129.0		
					M _{max}		68.5	112.5	146.4	226.7		
					η _{eto}		-	-	-	-		
22P08-...2F□□	120.0	760	23.5	9.60	M ₀	115.0	135.0	135.0	135.0			
					M _N	115.0	120.0	120.0	120.0			
					M _{0,max}	115.0	166.0	242.0	267.0			
					M _{max}	185.0	247.0	338.8	345.8			
					η _{eto}	-	-	-	-			
22P14-...2F□□	115.0	1425	40.0	17.20	M ₀			135.0	135.0	135.0		
					M _N			115.0	115.0	115.0		
					M _{0,max}			146.0	160.0	264.0		
					M _{max}			230.1	292.9	341.8		
					η _{eto}			-	-	-		
22P17-...2F□□	112.0	1670	44.5	19.60	M ₀			124.0	134.0	135.0	135.0	
					M _N			112.0	112.0	112.0	112.0	
					M _{0,max}			124.0	140.0	240.0	335.0	
					M _{max}			180.5	227.7	342.1	378.3	
					η _{eto}			-	-	-	-	
22P29-...2F□□	110.0	2935	77.8	33.80	M ₀					118.0	135.0	135.0
					M _N					110.0	110.0	110.0
					M _{0,max}					122.0	171.0	200.0
					M _{max}					215.6	273.1	355.1
					η _{eto}					-	-	-
26T05-...2F□□	280.0	550	42.4	16.10	M ₀		191.0	290.0	290.0	290.0		
					M _N		191.0	280.0	280.0	280.0		
					M _{0,max}		191.0	303.0	333.0	615.0		
					M _{max}		313.0	482.0	612.0	751.0		
					η _{eto}		-	-	-	-		
26T10-...2F□□	260.0	1030	69.6	28.00	M ₀				159.0	290.0	290.0	
					M _N				197.0	260.0	260.0	
					M _{0,max}				159.0	300.0	440.0	
					M _{max}				343.0	552.0	671.0	
					η _{eto}				-	-	-	

- I... [A], M... [Nm], n... [r/min], P... [kW]
- If the motors are operated at a lower switching frequency, please contact your Lenze sales office!

MCA asynchronous servo motors

Technical data



Selection tables, Servo Inverter 9300

Forced ventilated IP23s motors

- The data applies to a mains connection voltage of 3 x 400 V and an inverter switching frequency of 8 kHz.

					EVS	9326-E□	9327-E□	9328-E□	9329-E□	9330-E□	9331-E□	9332-E□
					I_N	23.5	32.0	47.0	59.0	89.0	110.0	145.0
					$I_{0,max}$	23.5	32.0	47.0	52.0	80.0	110.0	126.0
MCA	M_N	n_N	I_N	P_N	I_{max}	35.3	48.0	70.5	88.5	133.5	165.0	217.5
26T12- ...2F□□	255.0	1200	83.3	32.00	M_0					232.0	290.0	290.0
					M_N					255.0	255.0	255.0
					$M_{0,max}$					258.0	327.0	397.0
					M_{max}					424.0	512.0	663.0
					η_{eto}					-	-	-
26T22- ...2F□□	230.0	2235	126.7	53.80	M_0						177.0	222.0
					M_N						177.0	230.0
					$M_{0,max}$						203.0	220.0
					M_{max}						315.0	432.0
					η_{eto}						-	-

- $I...$ [A], $M...$ [Nm], $n...$ [r/min], $P...$ [kW]
- If the motors are operated at a lower switching frequency, please contact your Lenze sales office!

MCA asynchronous servo motors

Technical data



Torque characteristics

- ▶ The data applies to a mains connection voltage of 3 x 400 V.
- ▶ You can find further torque characteristics at [Lenze website](#).

MCA10140 (non-ventilated)

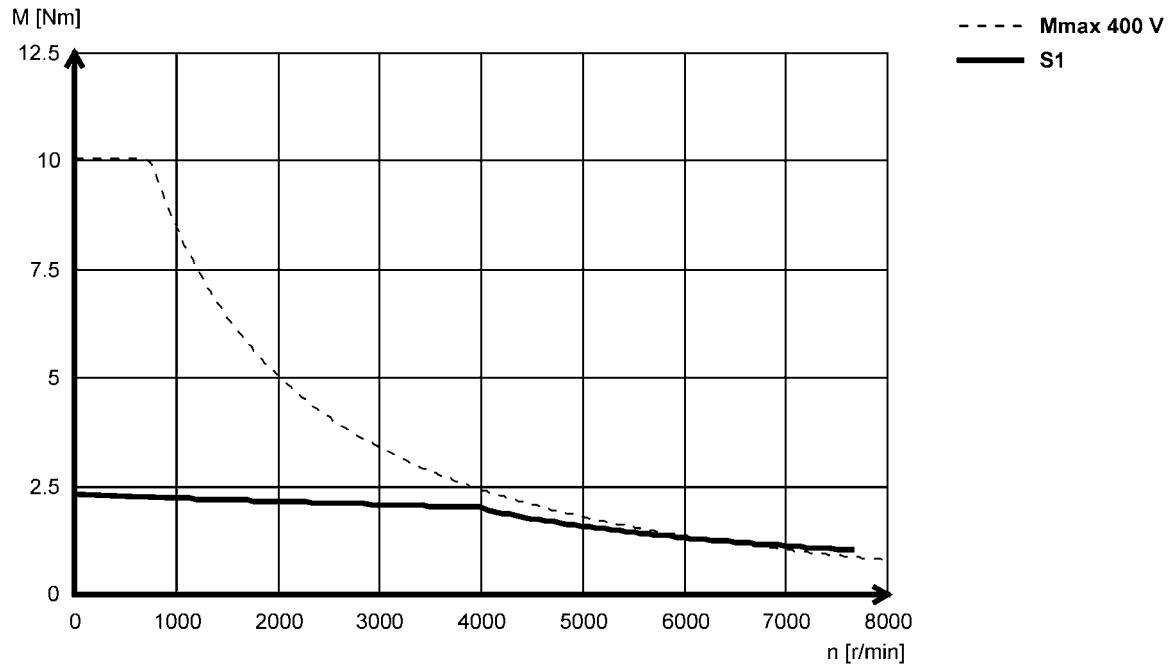

MCA asynchronous servo motors

Technical data



Torque characteristics

- ▶ The data applies to a mains connection voltage of 3 x 400 V.
- ▶ You can find further torque characteristics at Lenze website.

MCA13134 (forced ventilated)

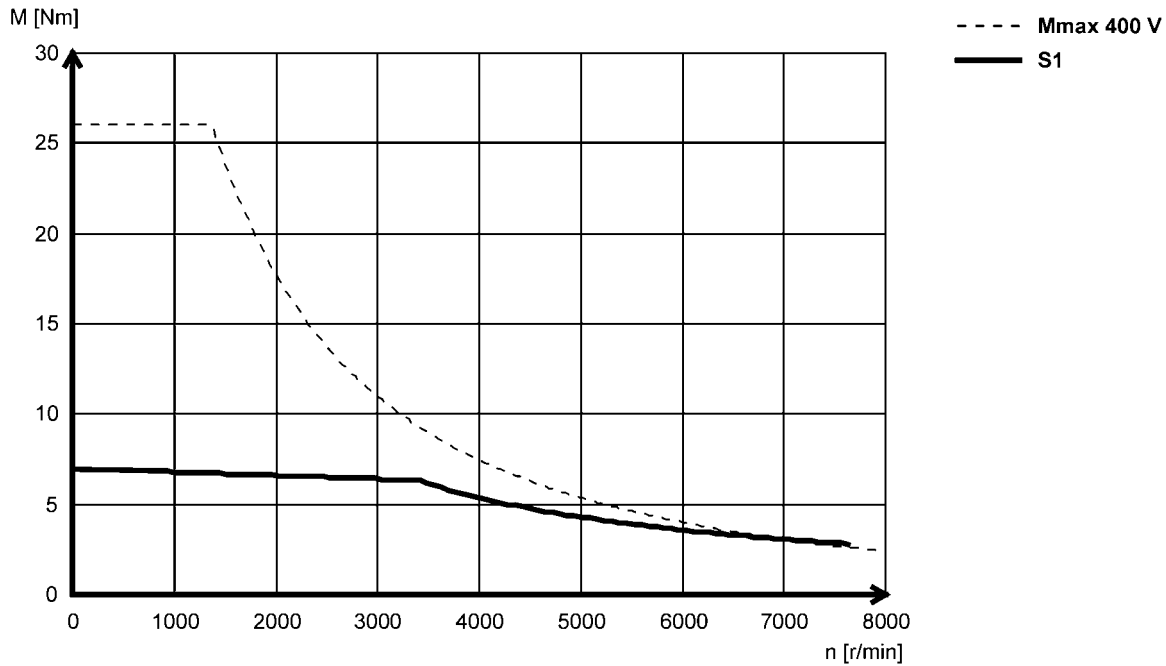

5.4

MCA13141 (non-ventilated)

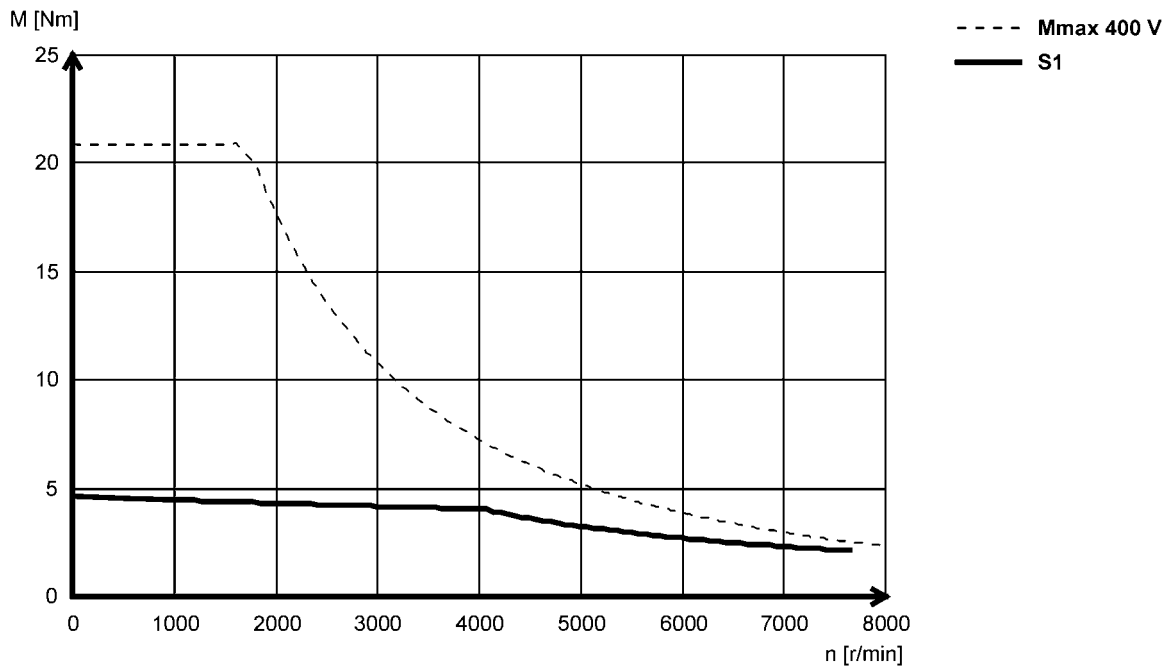

MCA asynchronous servo motors



Technical data

Torque characteristics

- ▶ The data applies to a mains connection voltage of 3 x 400 V.
- ▶ You can find further torque characteristics at [Lenze website](#).

MCA14L16 (forced ventilated)

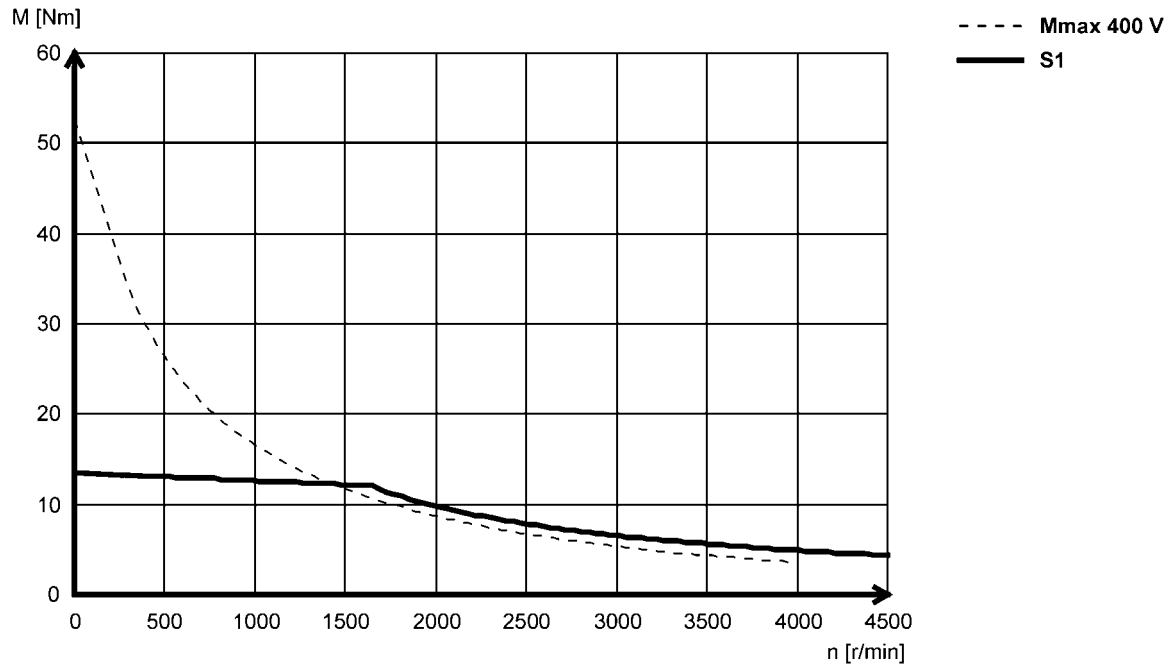

5.4

MCA14L20 (non-ventilated)

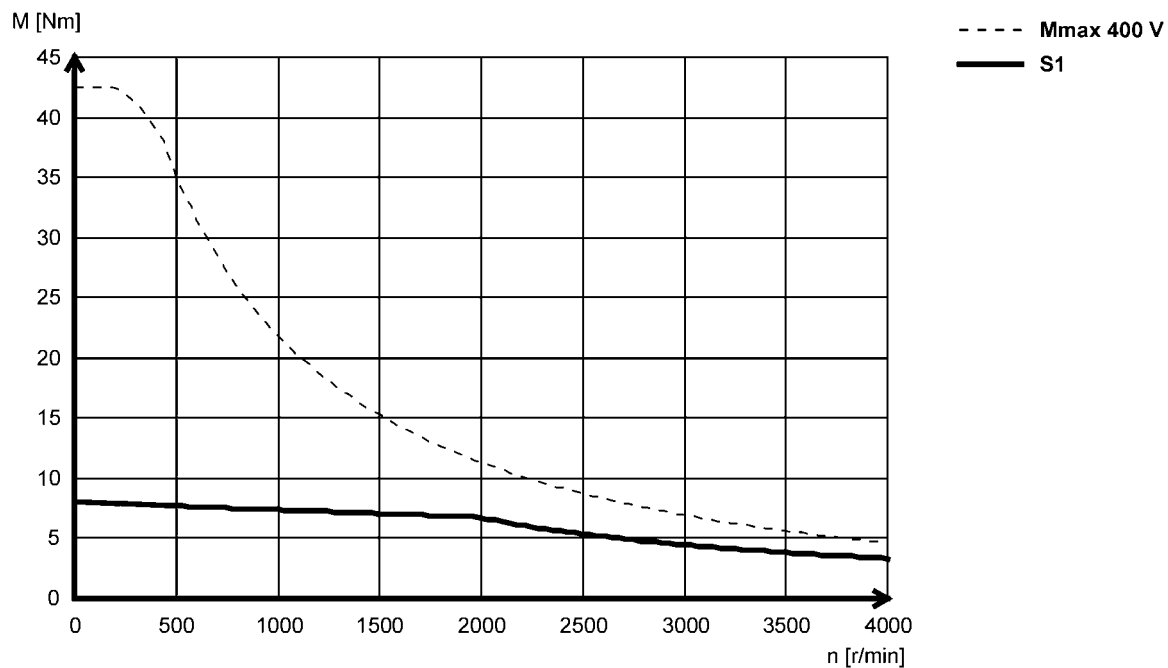

MCA asynchronous servo motors

Technical data



Torque characteristics

- ▶ The data applies to a mains connection voltage of 3 x 400 V.
- ▶ You can find further torque characteristics at Lenze website.

MCA14L35 (forced ventilated)

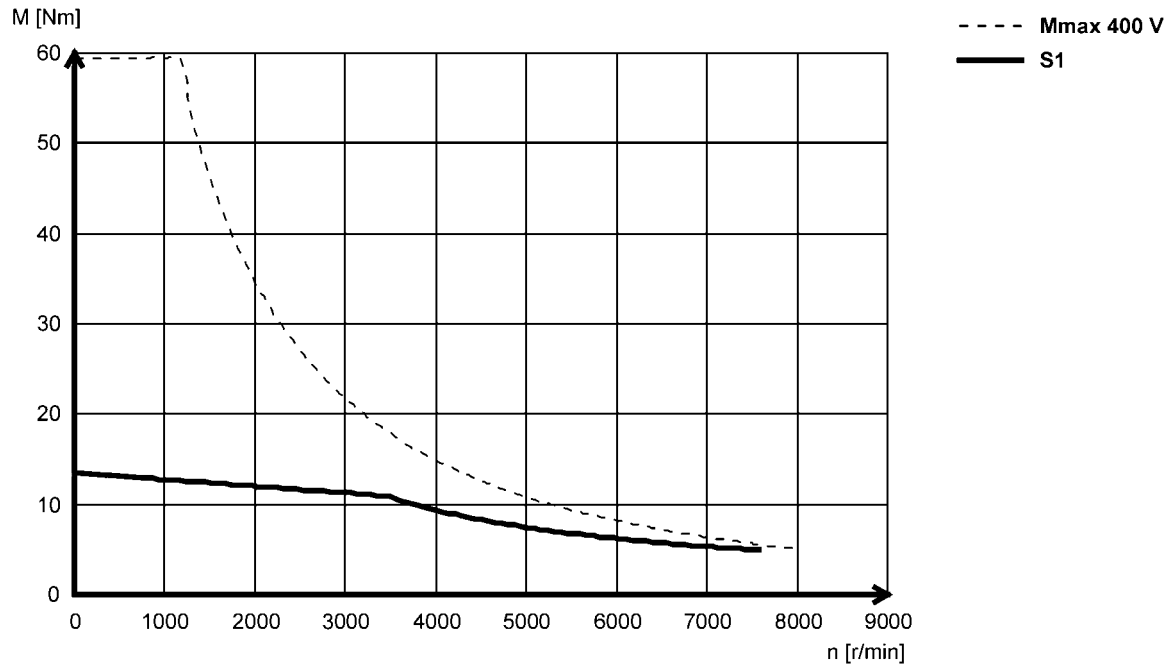

5.4

MCA14L41 (non-ventilated)

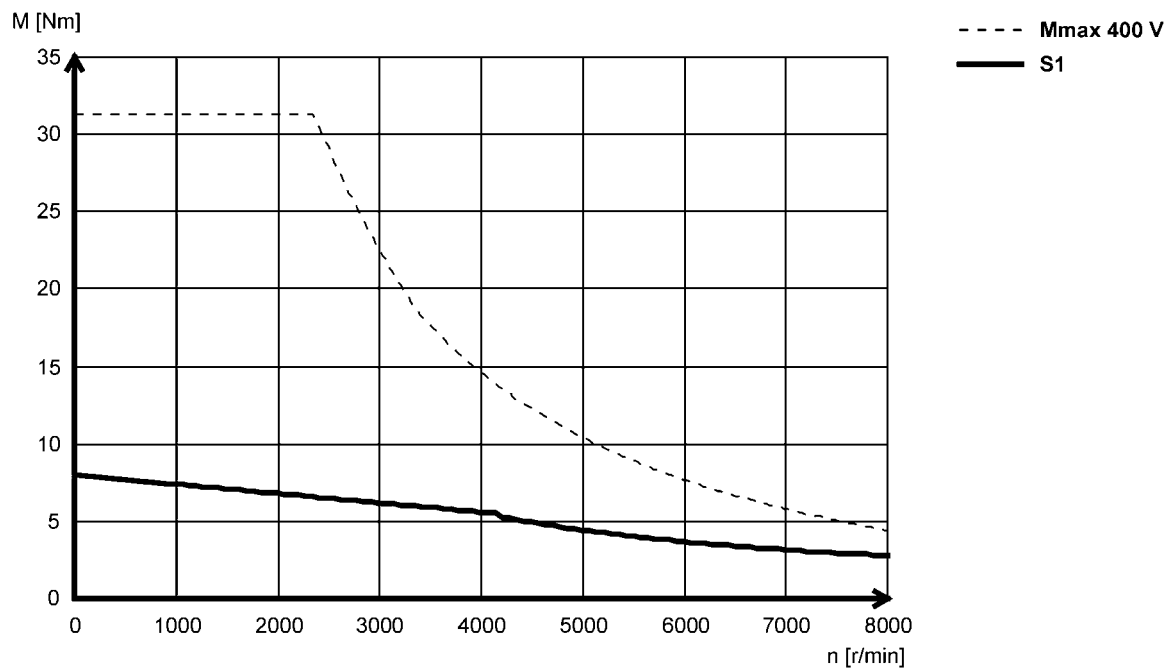

MCA asynchronous servo motors

Technical data



Torque characteristics

- ▶ The data applies to a mains connection voltage of 3 x 400 V.
- ▶ You can find further torque characteristics at [Lenze website](#).

MCA17N17 (forced ventilated)

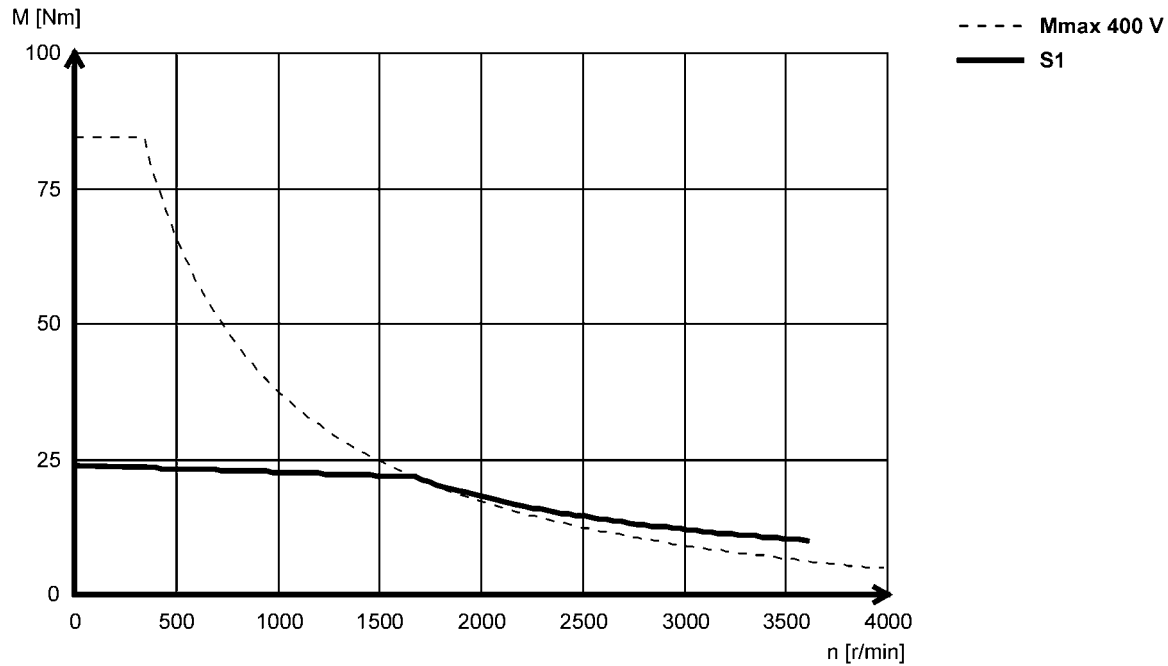

5.4

MCA17N23 (non-ventilated)

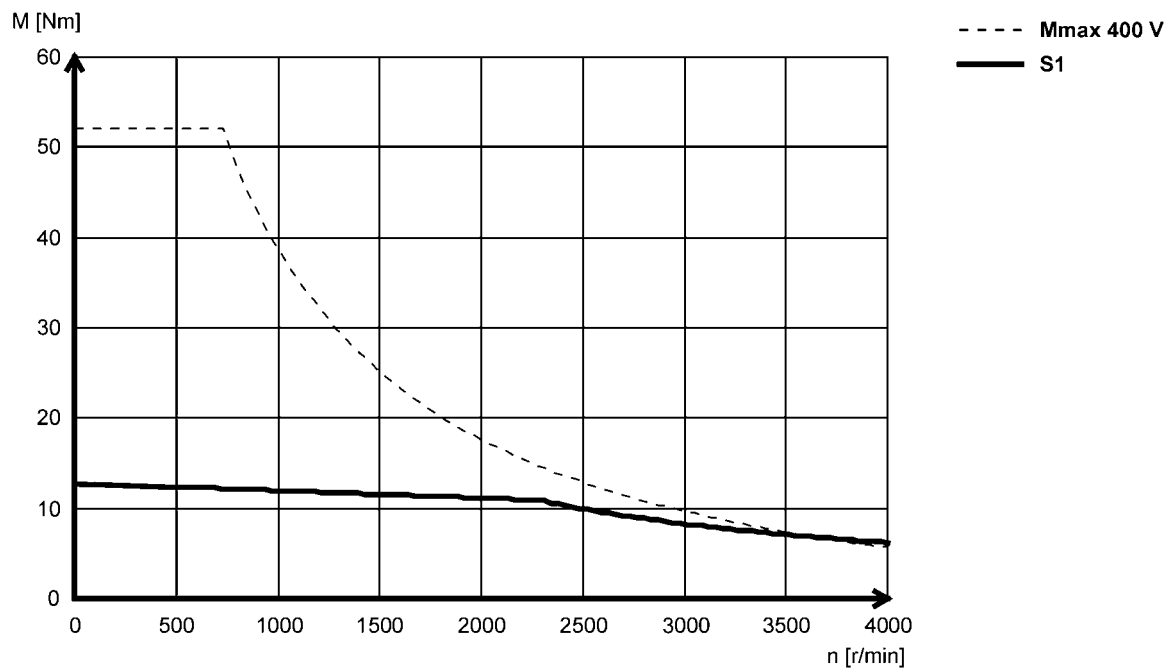

MCA asynchronous servo motors

Technical data



Torque characteristics

- ▶ The data applies to a mains connection voltage of 3 x 400 V.
- ▶ You can find further torque characteristics at [Lenze website](#).

MCA17N35 (forced ventilated)

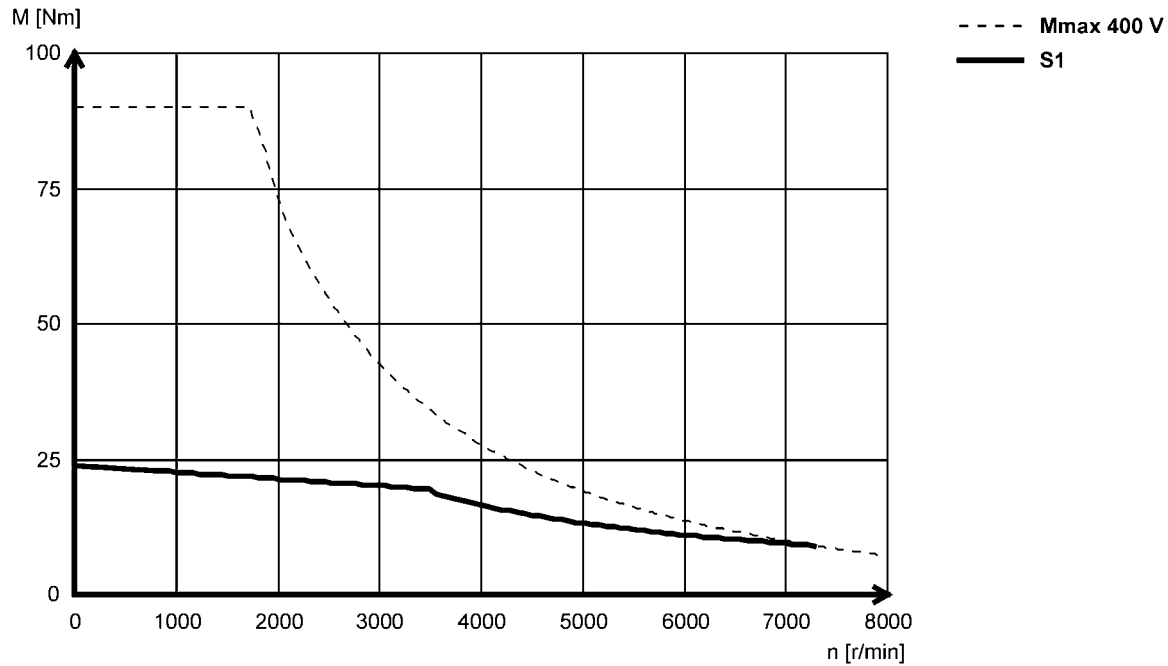

5.4

MCA17N41 (non-ventilated)

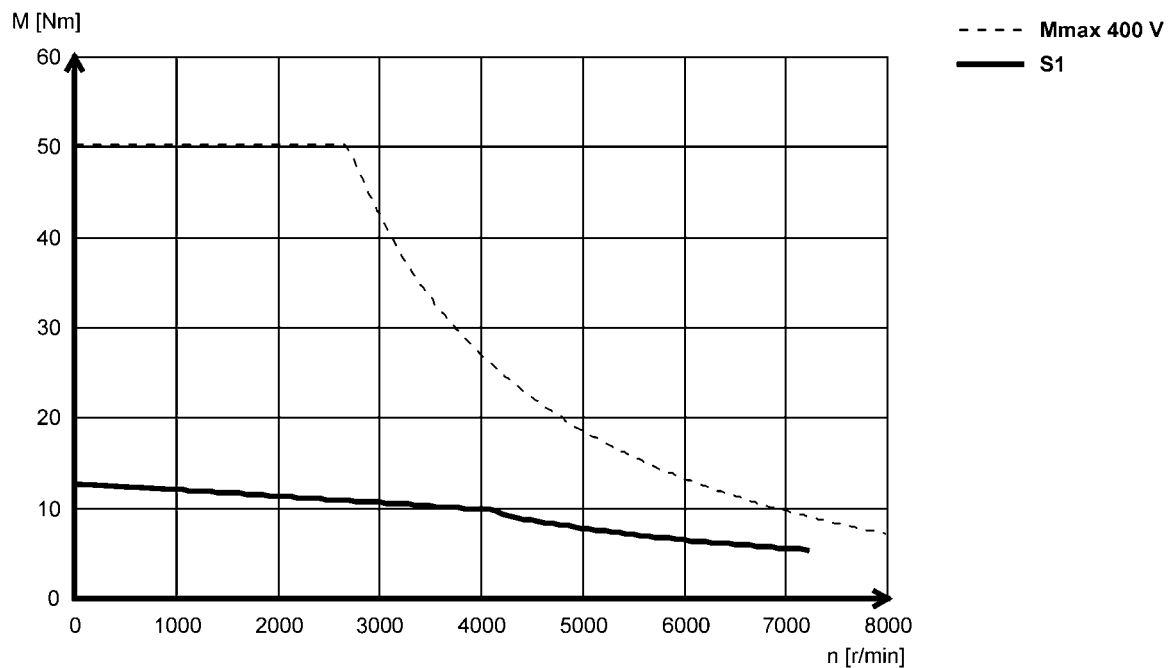

MCA asynchronous servo motors

Technical data



Torque characteristics

- ▶ The data applies to a mains connection voltage of 3 x 400 V.
- ▶ You can find further torque characteristics at [Lenze website](#).

MCA19S17 (forced ventilated)

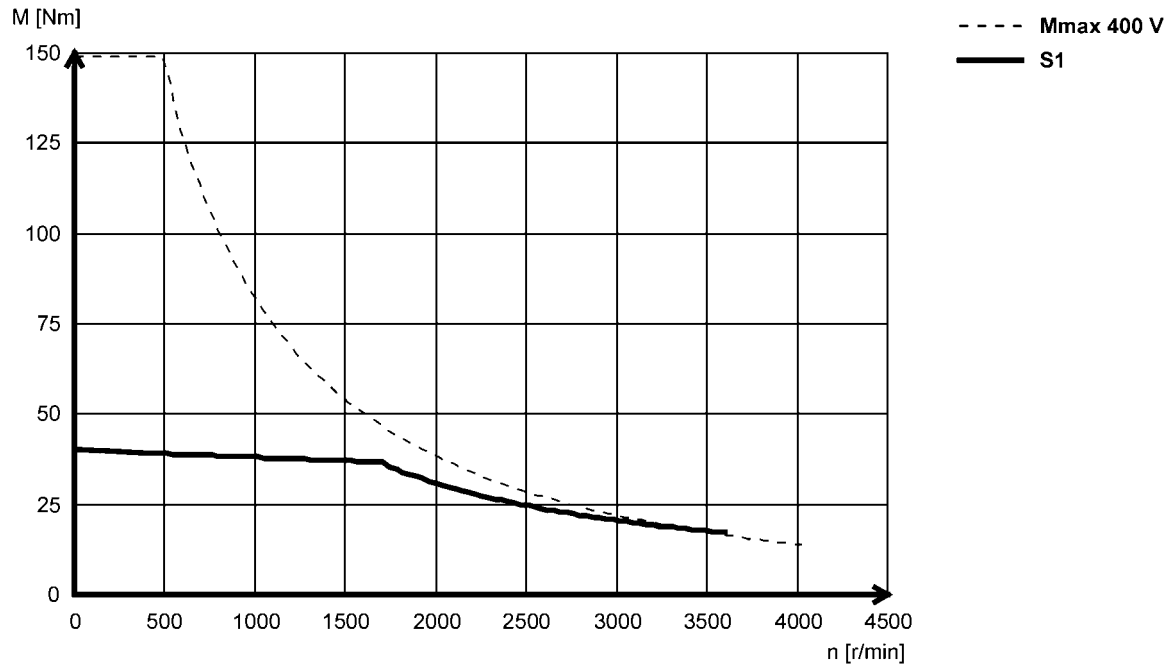

5.4

MCA19S23 (non-ventilated)

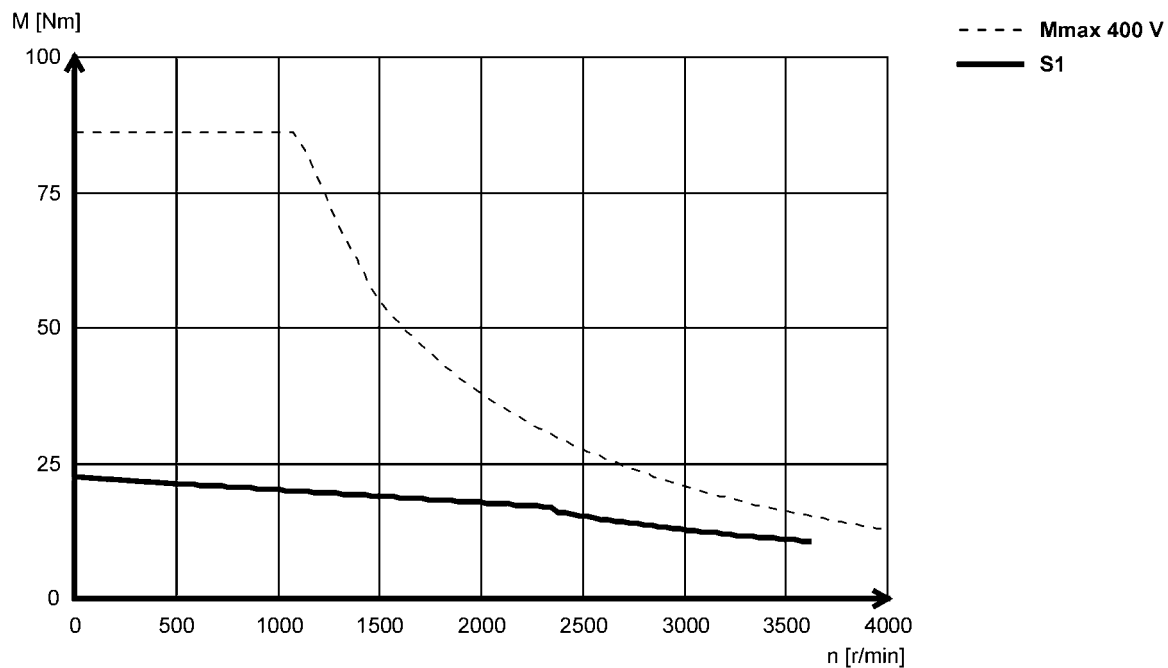

MCA asynchronous servo motors



Technical data

Torque characteristics

- ▶ The data applies to a mains connection voltage of 3 x 400 V.
- ▶ You can find further torque characteristics at Lenze website.

MCA19S35 (forced ventilated)

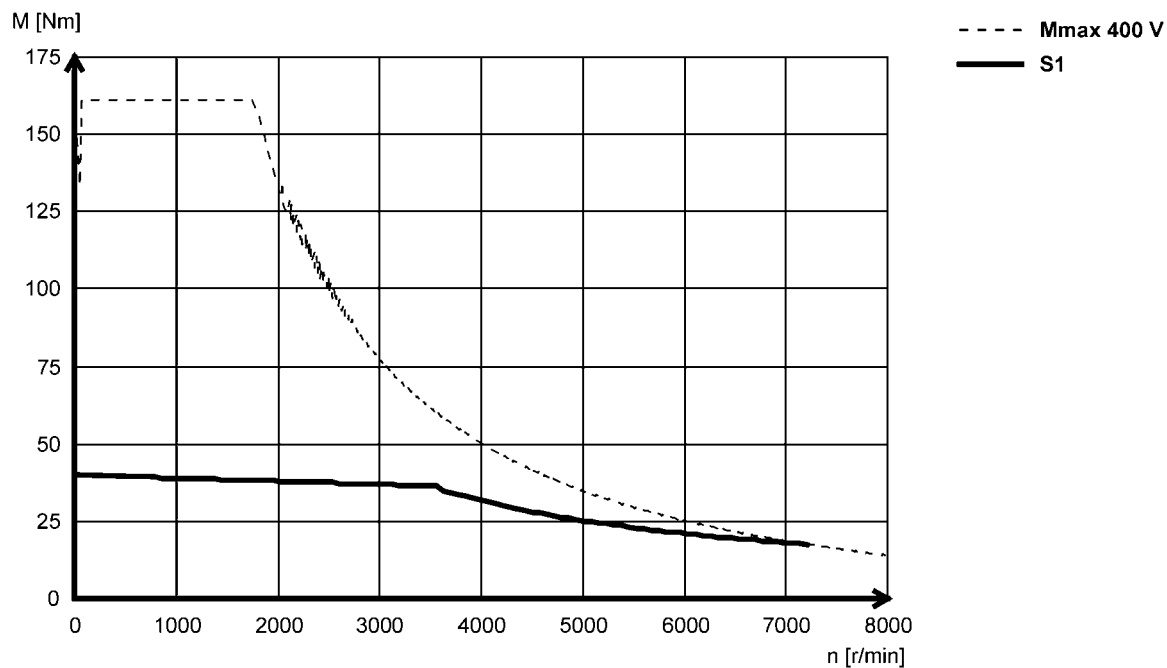

5.4

MCA19S42 (non-ventilated)

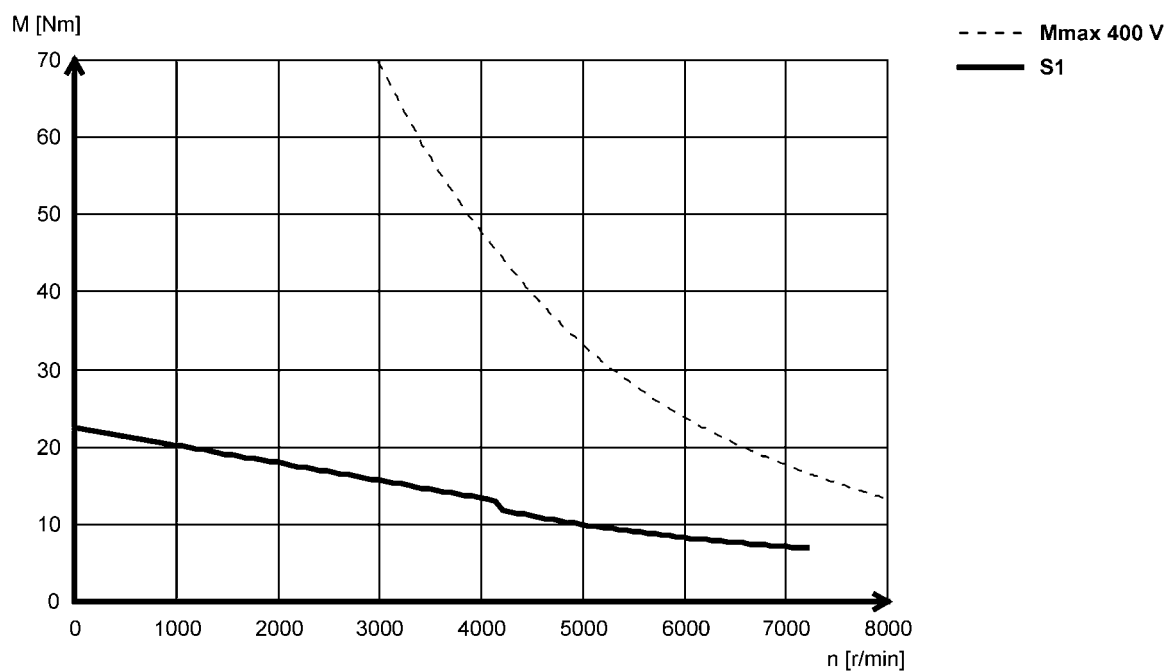

MCA asynchronous servo motors

Technical data



Torque characteristics

- ▶ The data applies to a mains connection voltage of 3 x 400 V.
- ▶ You can find further torque characteristics at Lenze website.

MCA20X14...2F□□ (forced ventilated)

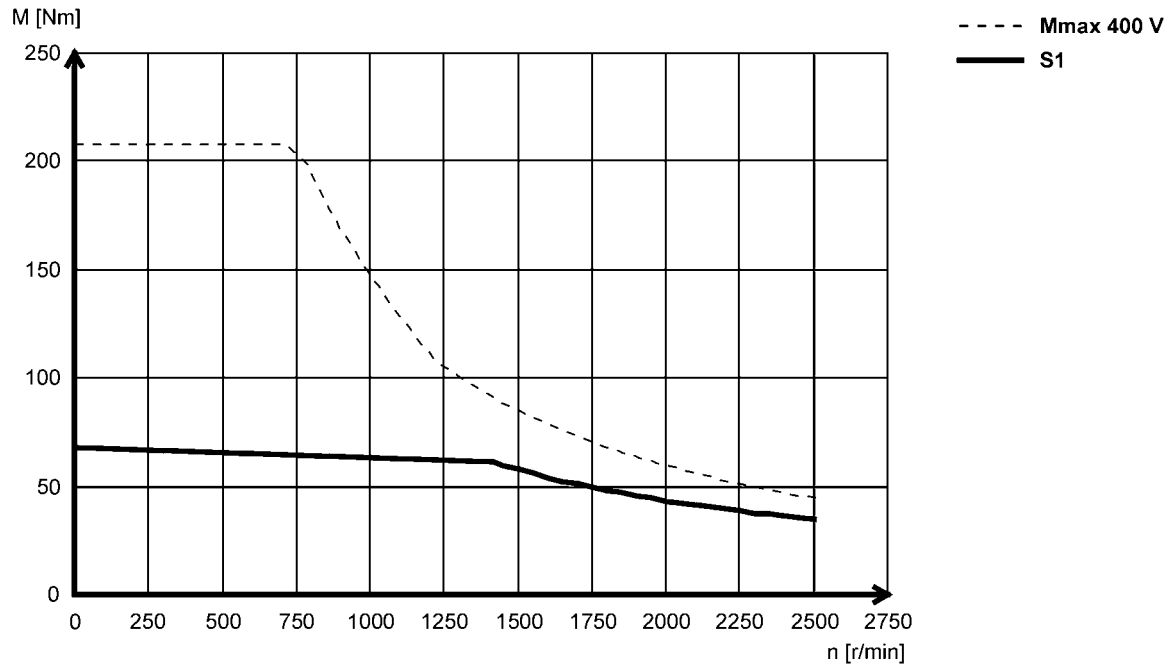

5.4

MCA20X29...2F□□ (forced ventilated)

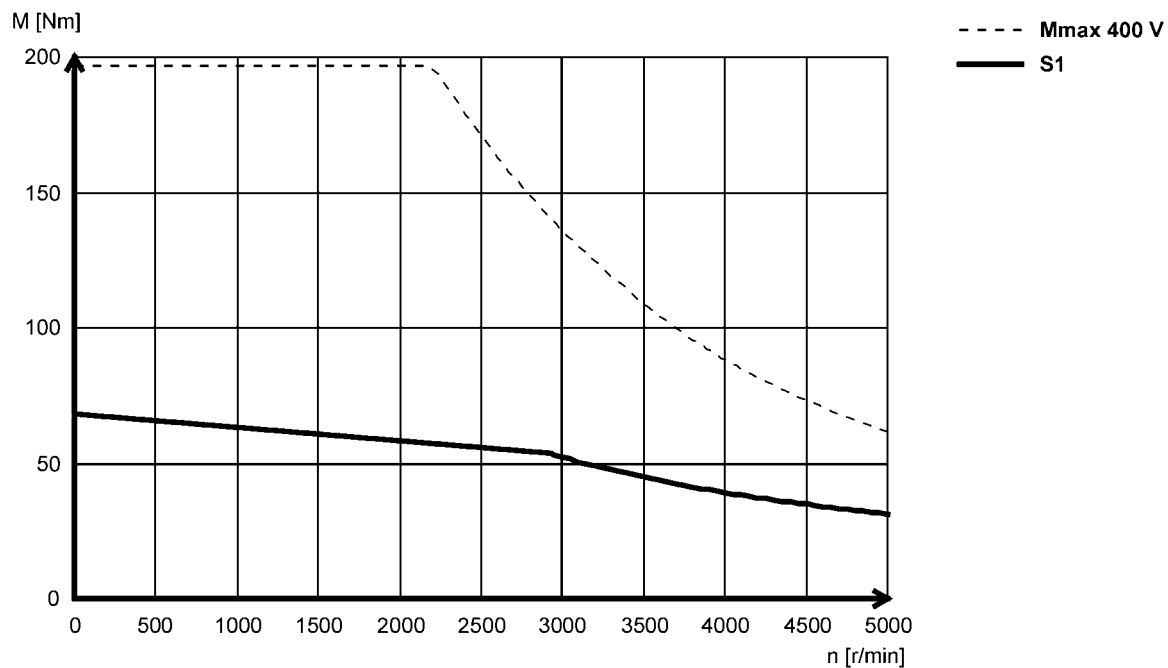

MCA asynchronous servo motors

Technical data



Torque characteristics

- ▶ The data applies to a mains connection voltage of 3 x 400 V.
- ▶ You can find further torque characteristics at Lenze website.

MCA21X17 (forced ventilated)

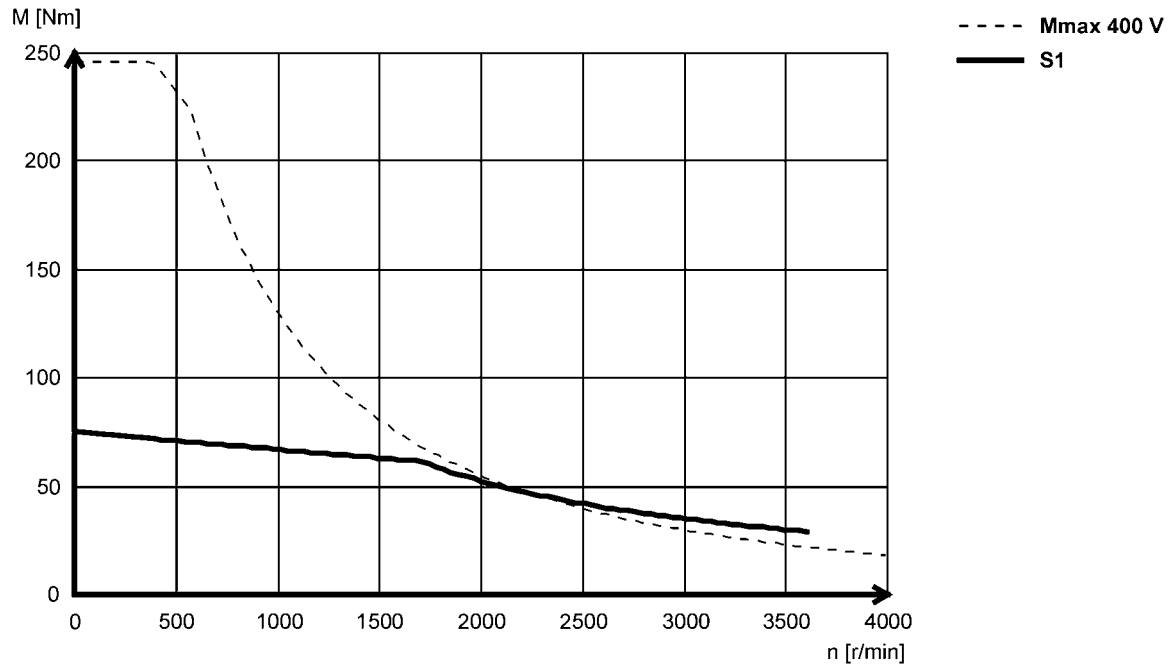

5.4

MCA21X25 (non-ventilated)

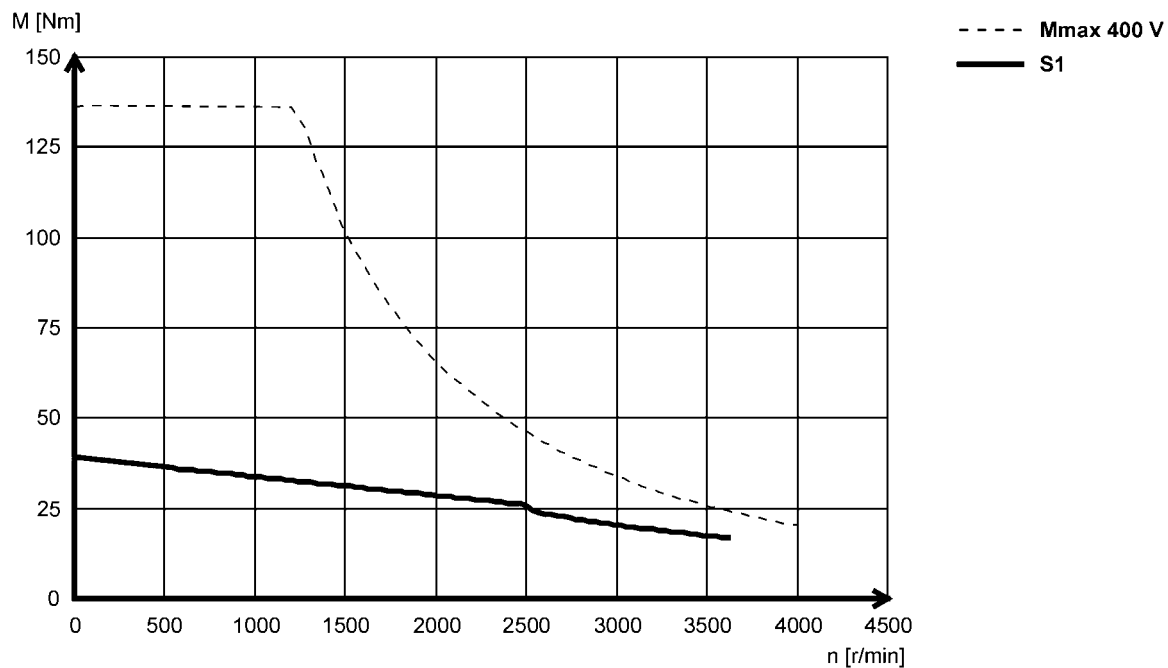

MCA asynchronous servo motors

Technical data



Torque characteristics

- ▶ The data applies to a mains connection voltage of 3 x 400 V.
- ▶ You can find further torque characteristics at Lenze website.

MCA21X35 (forced ventilated)

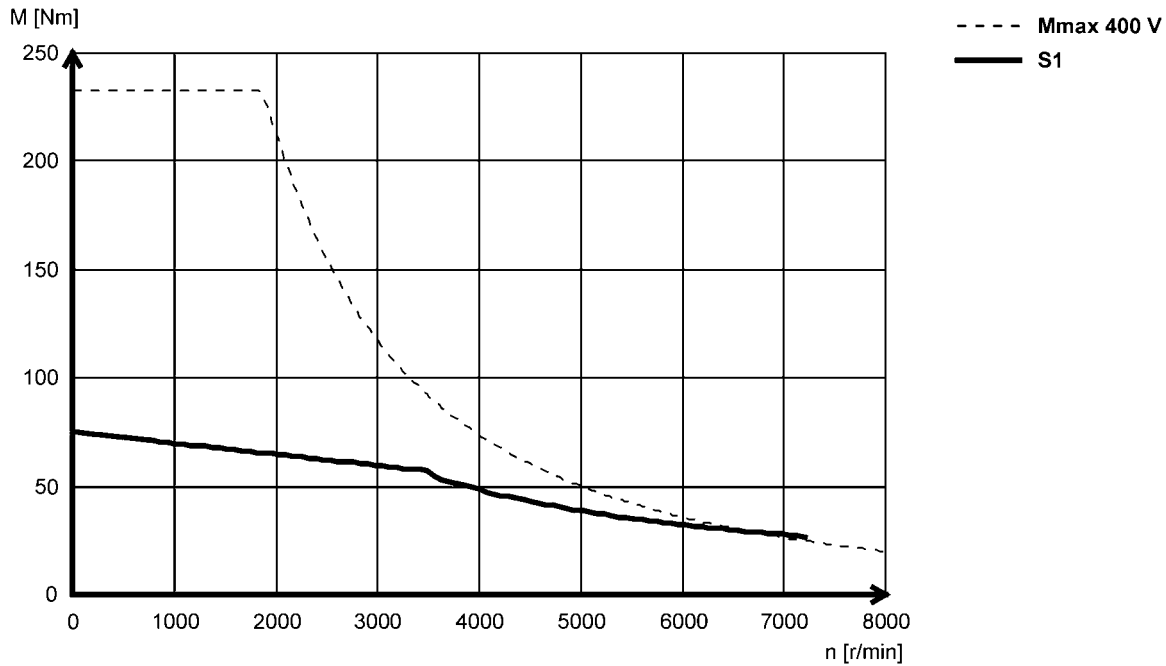

5.4

MCA21X42 (non-ventilated)

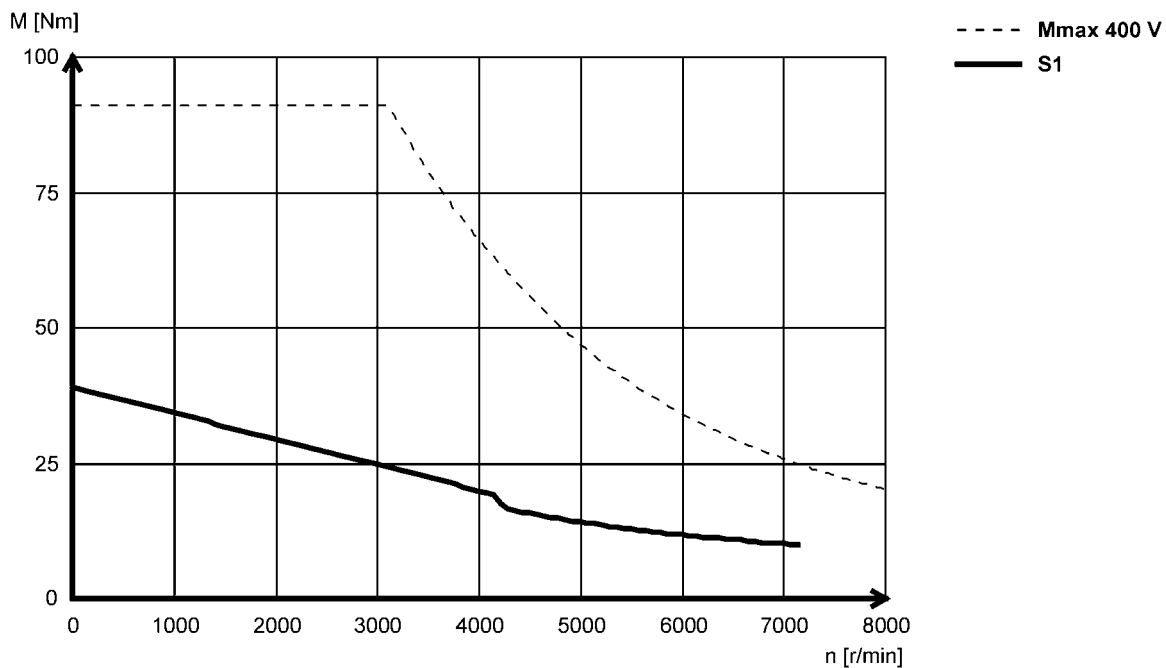

MCA asynchronous servo motors



Technical data

Torque characteristics

- ▶ The data applies to a mains connection voltage of 3 x 400 V.
- ▶ You can find further torque characteristics at Lenze website.

MCA22P08...5F□□ (forced ventilated)

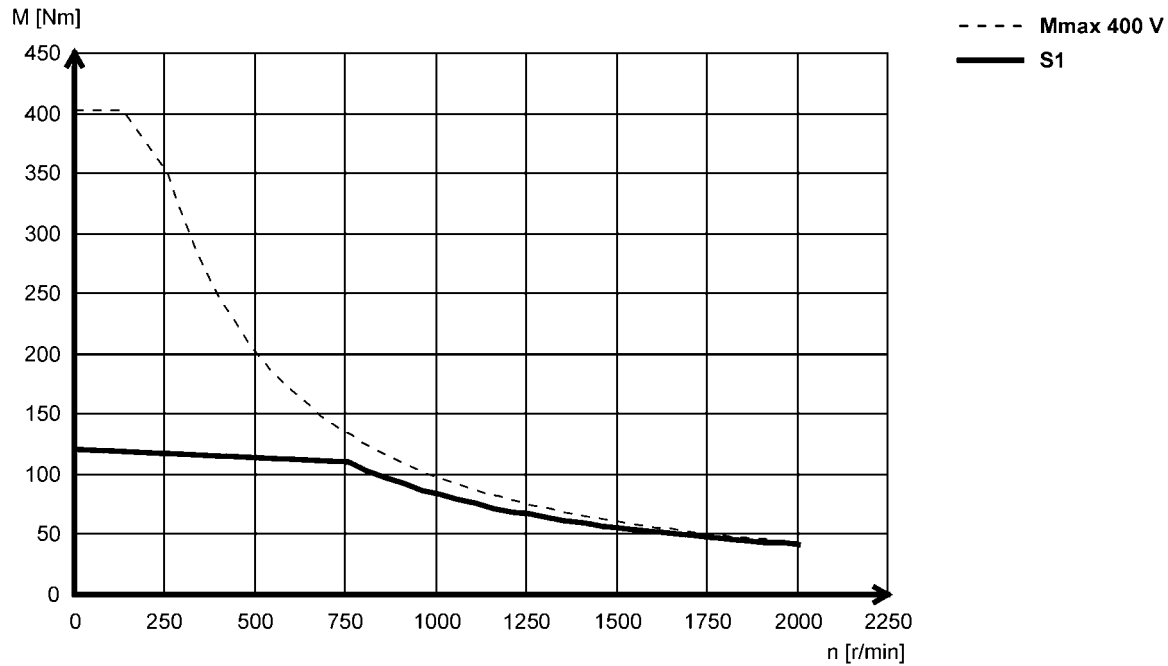

5.4

MCA22P08...2F□□ (forced ventilated)

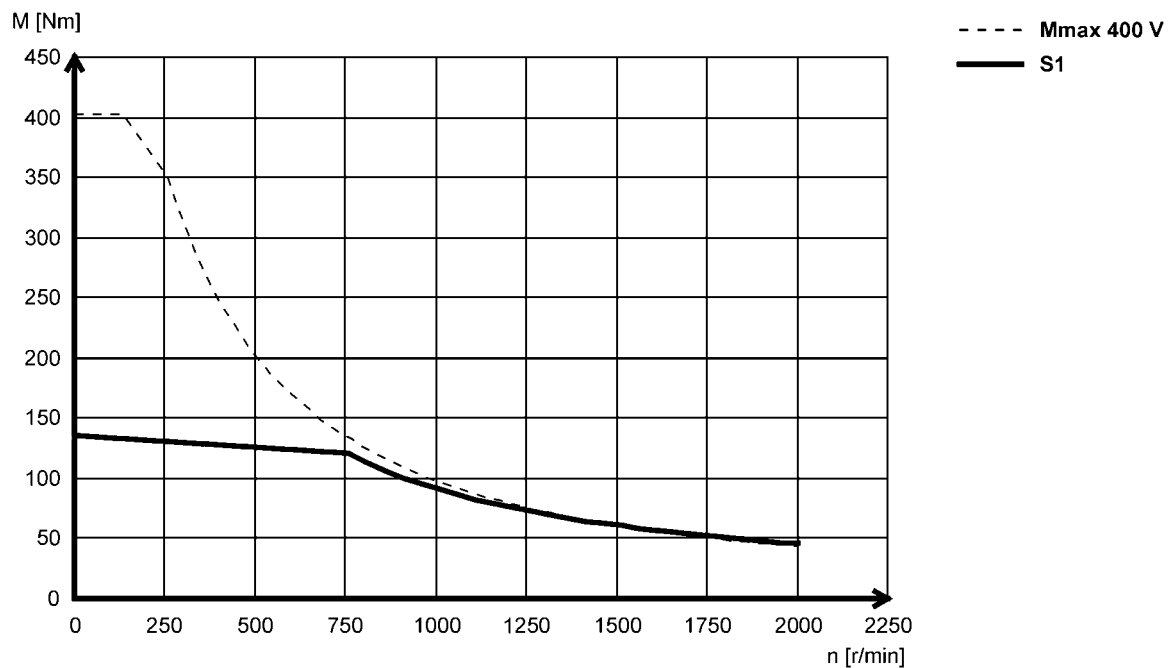

MCA asynchronous servo motors

Technical data



Torque characteristics

- ▶ The data applies to a mains connection voltage of 3 x 400 V.
- ▶ You can find further torque characteristics at Lenze website.

MCA22P14...5F□□ (forced ventilated)

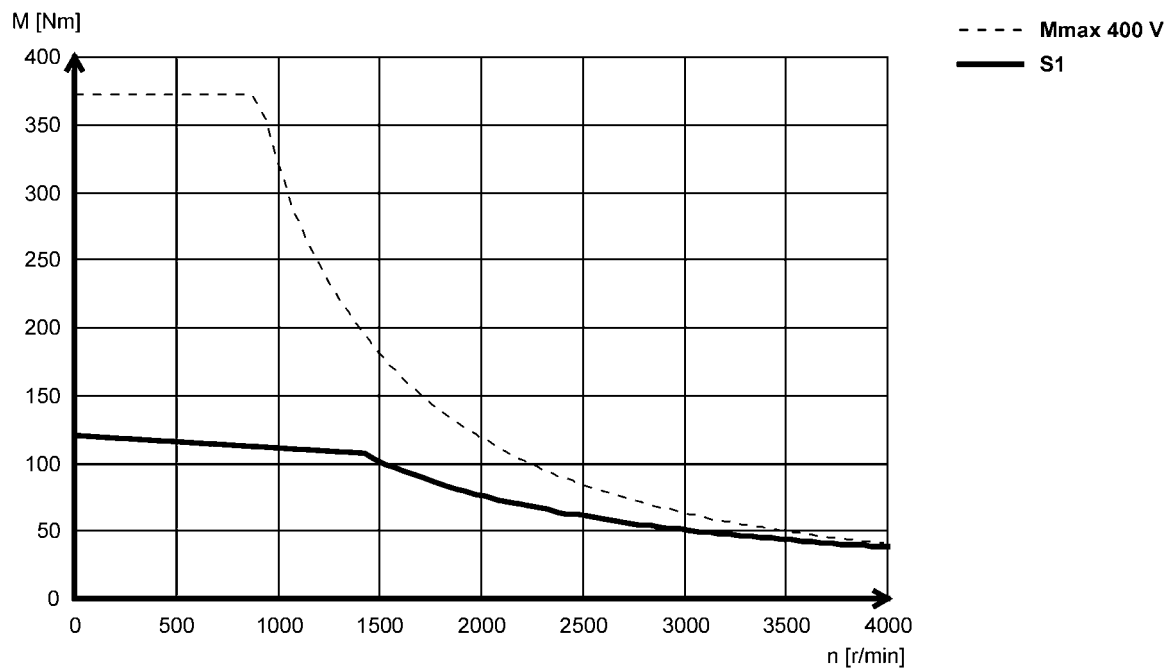

5.4

MCA22P14...2F□□ (forced ventilated)

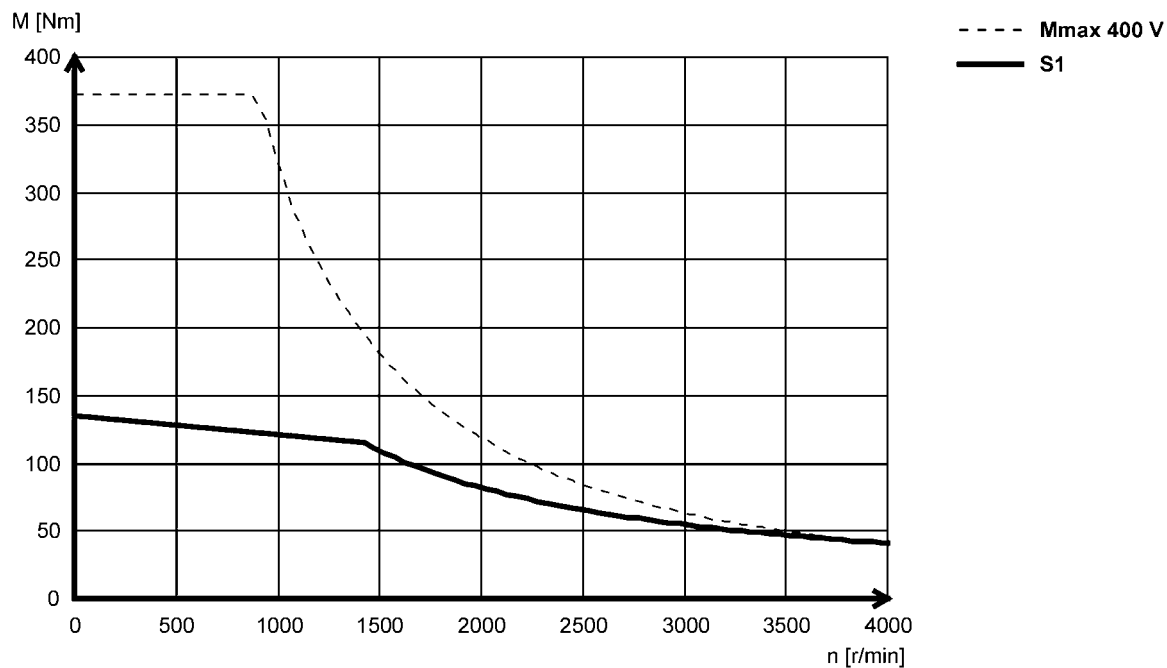

MCA asynchronous servo motors

Technical data



Torque characteristics

- ▶ The data applies to a mains connection voltage of 3 x 400 V.
- ▶ You can find further torque characteristics at Lenze website.

MCA22P17...5F□□ (forced ventilated)

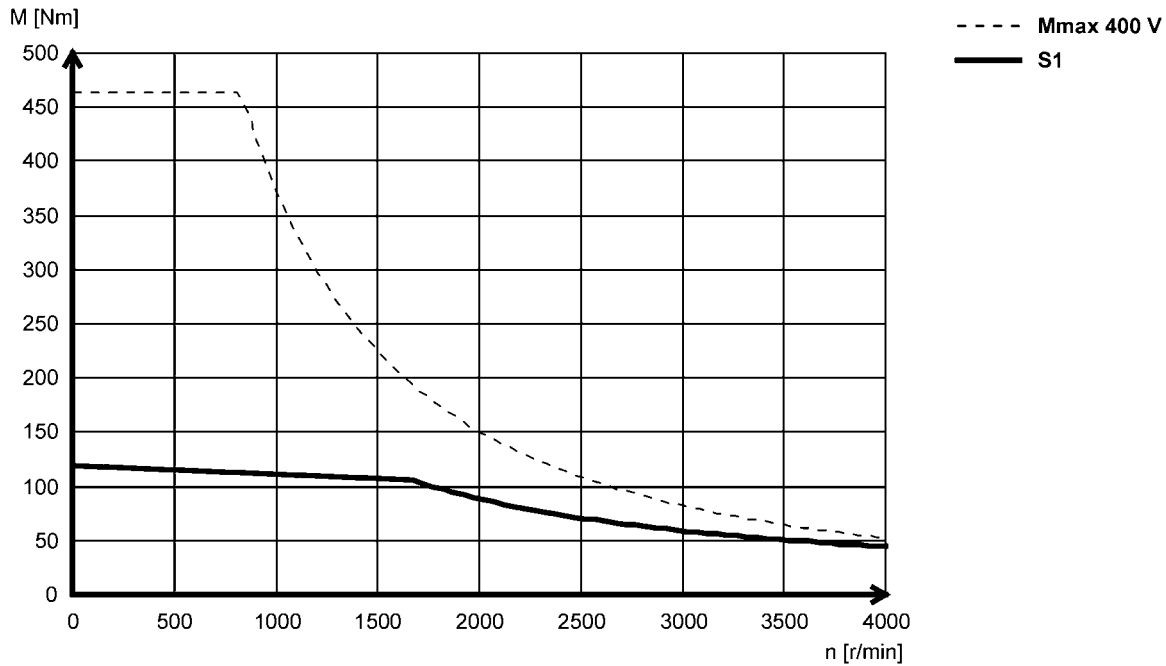

5.4

MCA22P17...2F□□ (forced ventilated)

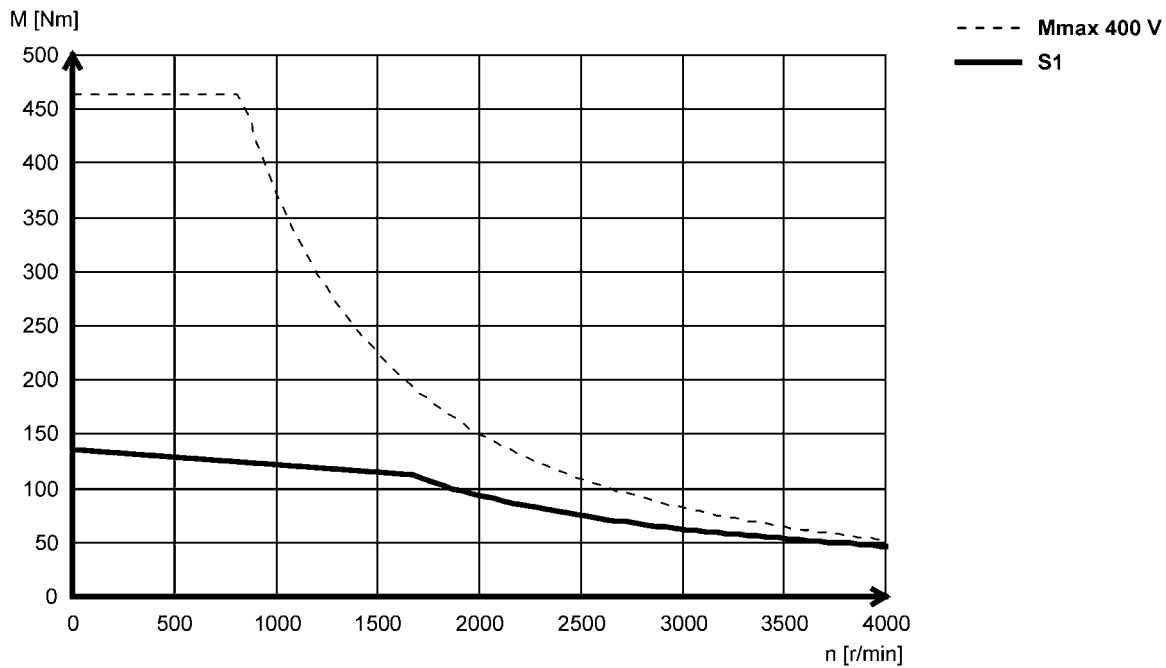

MCA asynchronous servo motors



Technical data

Torque characteristics

- ▶ The data applies to a mains connection voltage of 3 x 400 V.
- ▶ You can find further torque characteristics at Lenze website.

MCA22P29...5F□□ (forced ventilated)

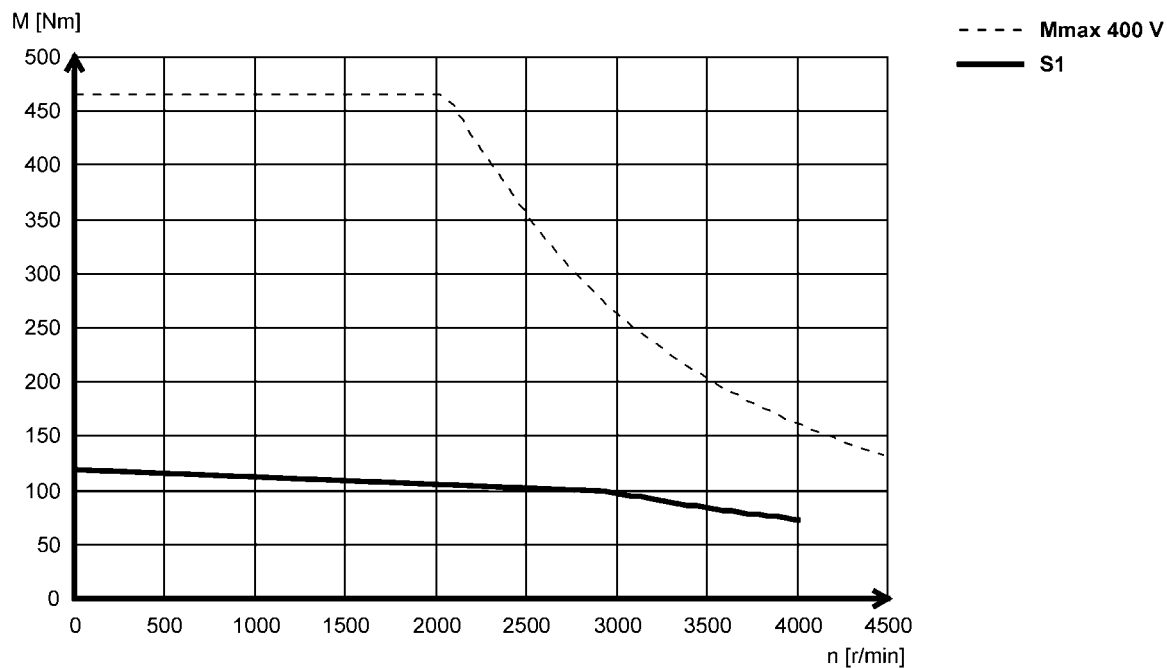

5.4

MCA22P29...2F□□ (forced ventilated)

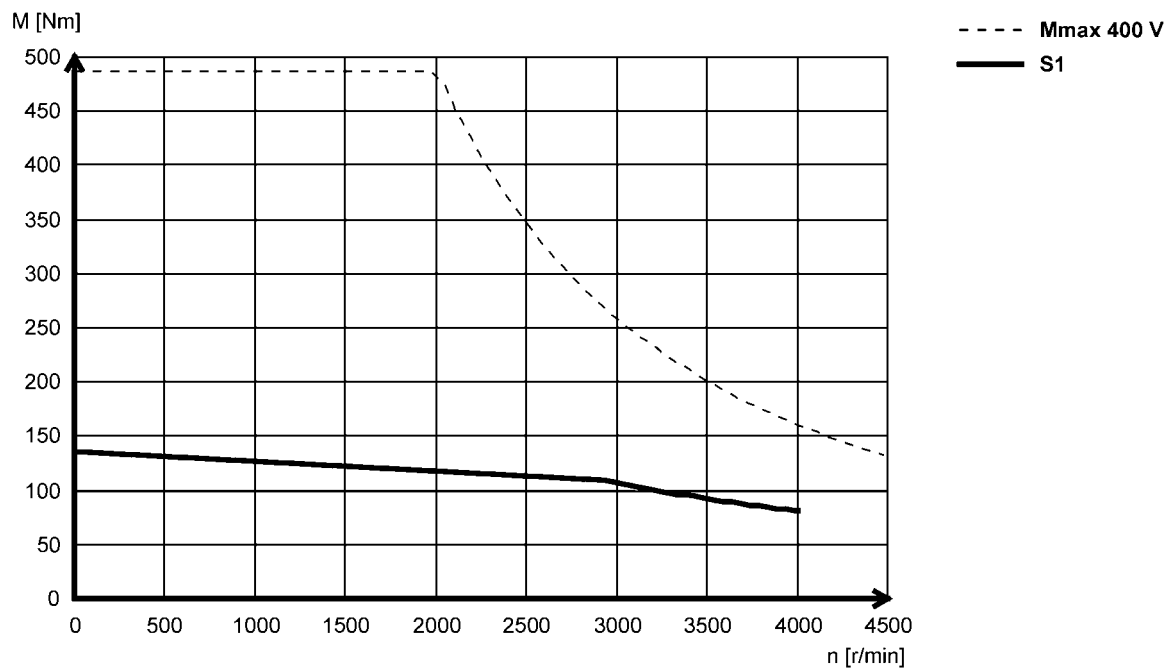

MCA asynchronous servo motors

Technical data



Torque characteristics

- ▶ The data applies to a mains connection voltage of 3 x 400 V.
- ▶ You can find further torque characteristics at Lenze website.

MCA26T05...5F□□ (forced ventilated)

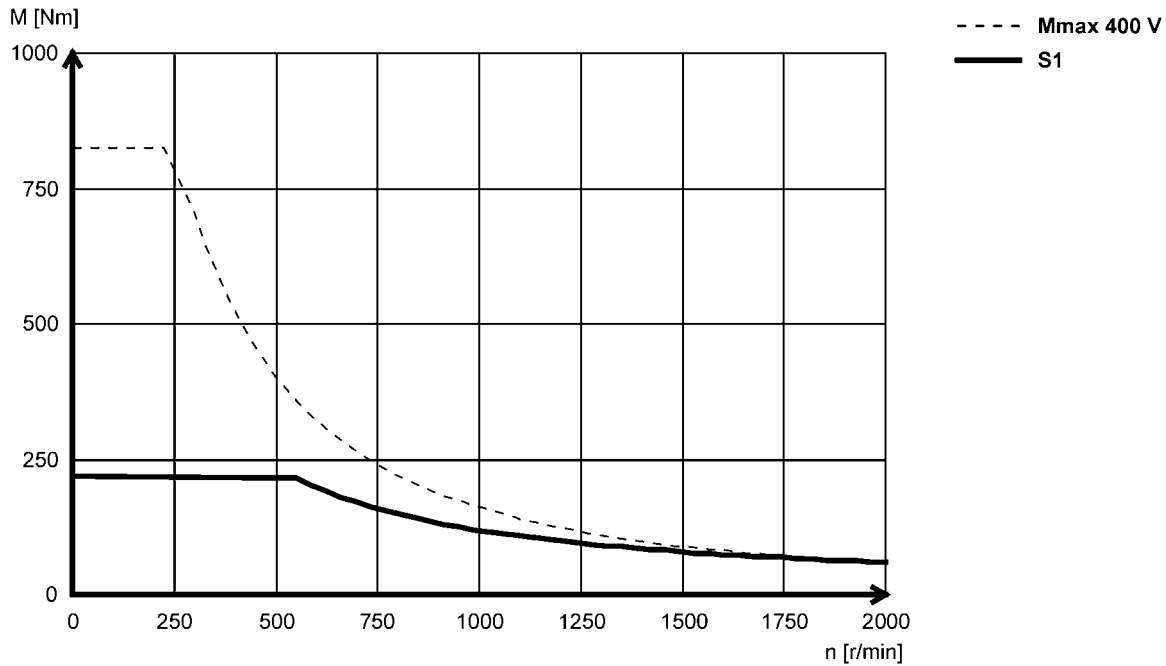

5.4

MCA26T05...2F□□ (forced ventilated)

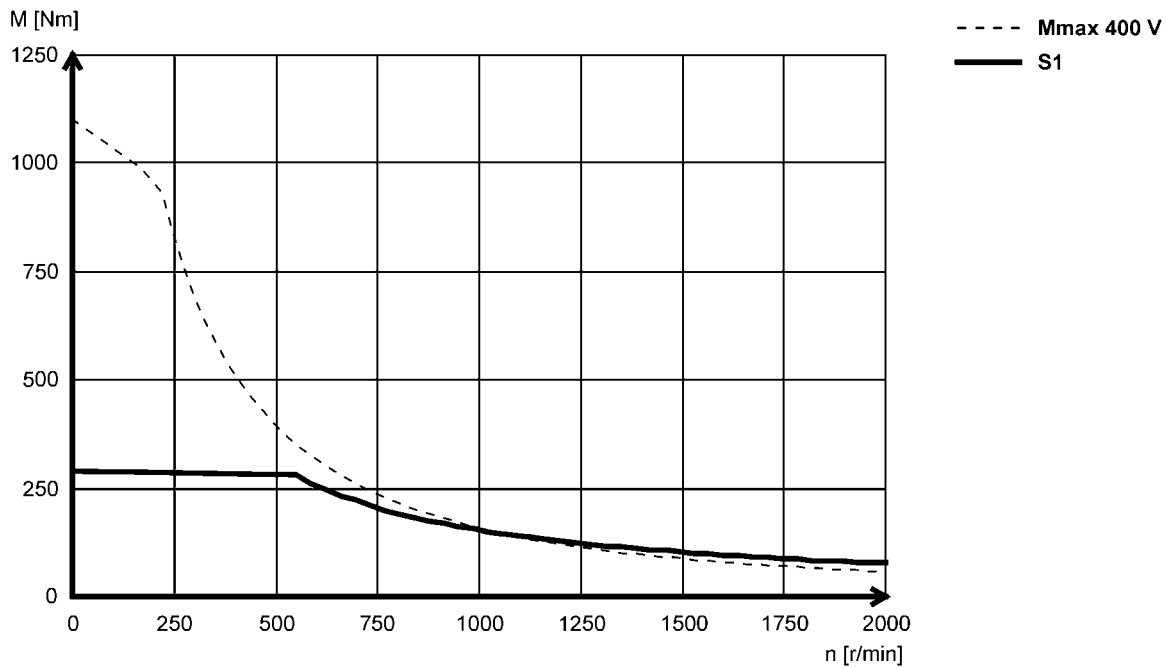

MCA asynchronous servo motors



Technical data

Torque characteristics

- ▶ The data applies to a mains connection voltage of 3 x 400 V.
- ▶ You can find further torque characteristics at [Lenze website](#).

MCA26T10...5F□□ (forced ventilated)

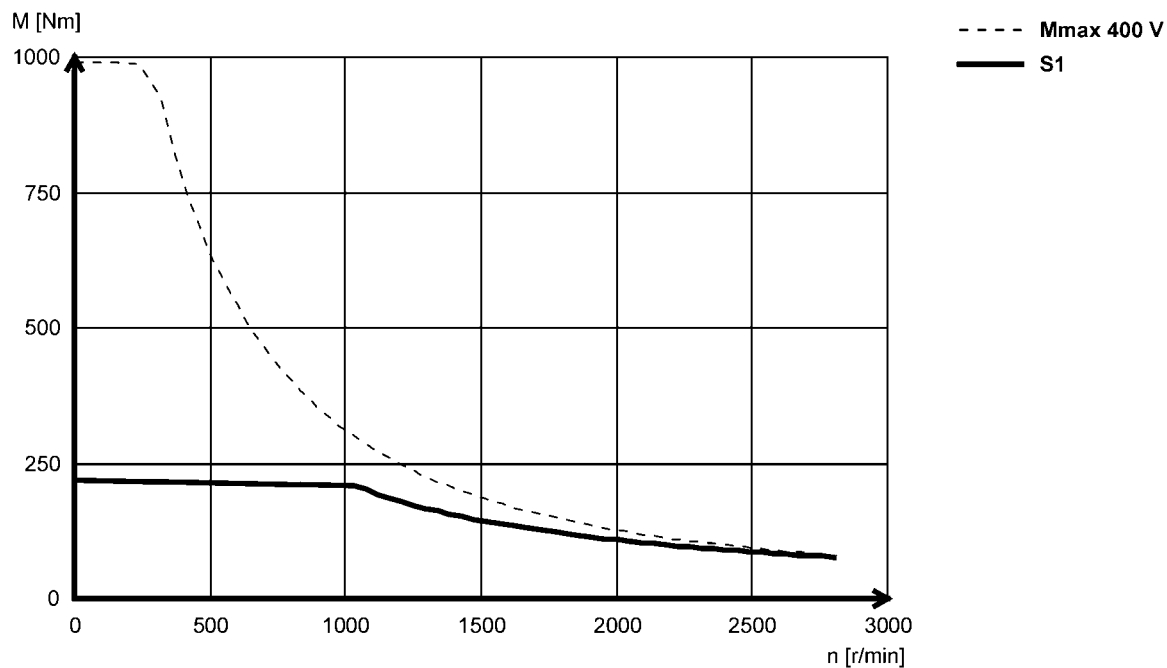

5.4

MCA26T10...2F□□ (forced ventilated)

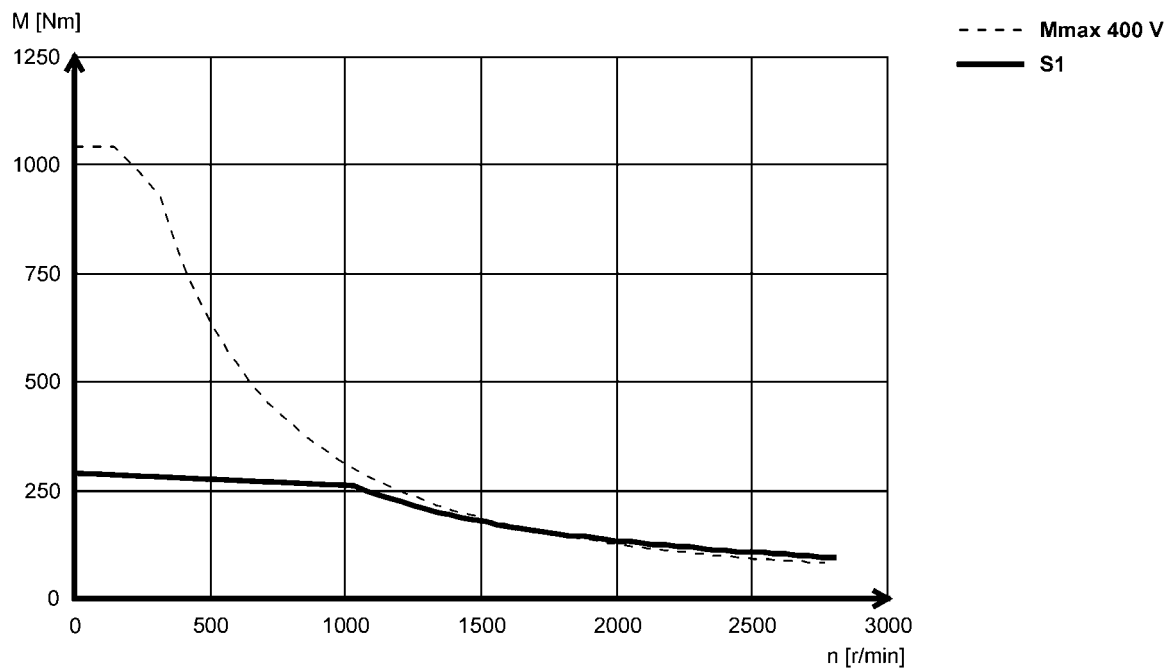

MCA asynchronous servo motors

Technical data



Torque characteristics

- ▶ The data applies to a mains connection voltage of 3 x 400 V.
- ▶ You can find further torque characteristics at Lenze website.

MCA26T12...5F□□ (forced ventilated)

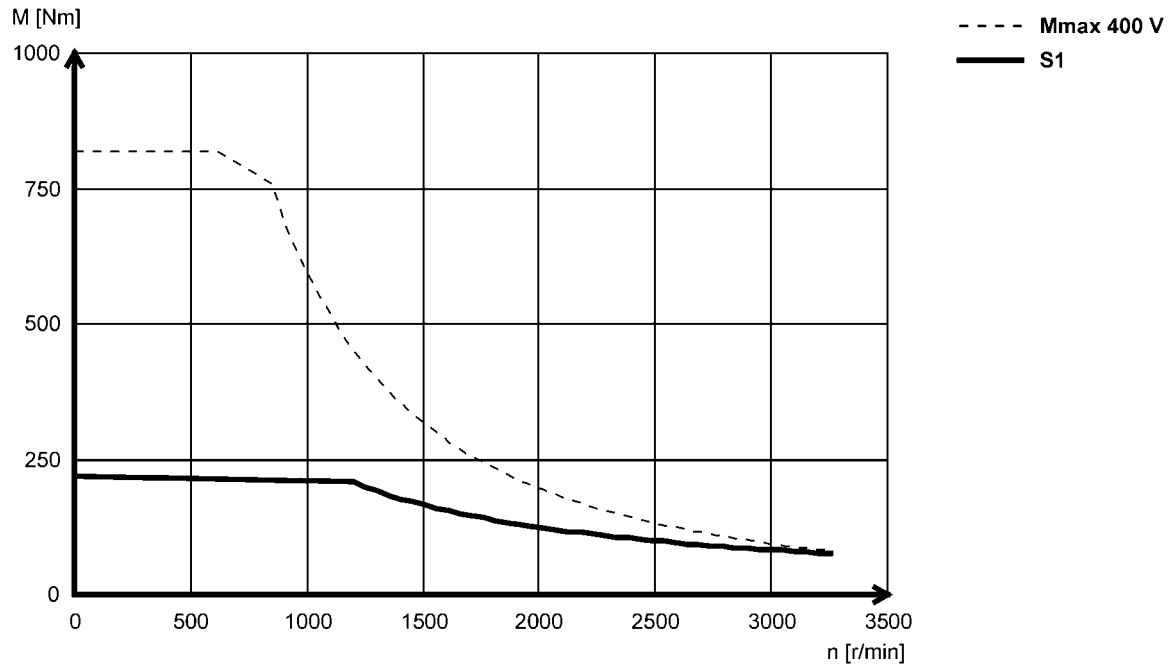

5.4

MCA26T12...2F□□ (forced ventilated)

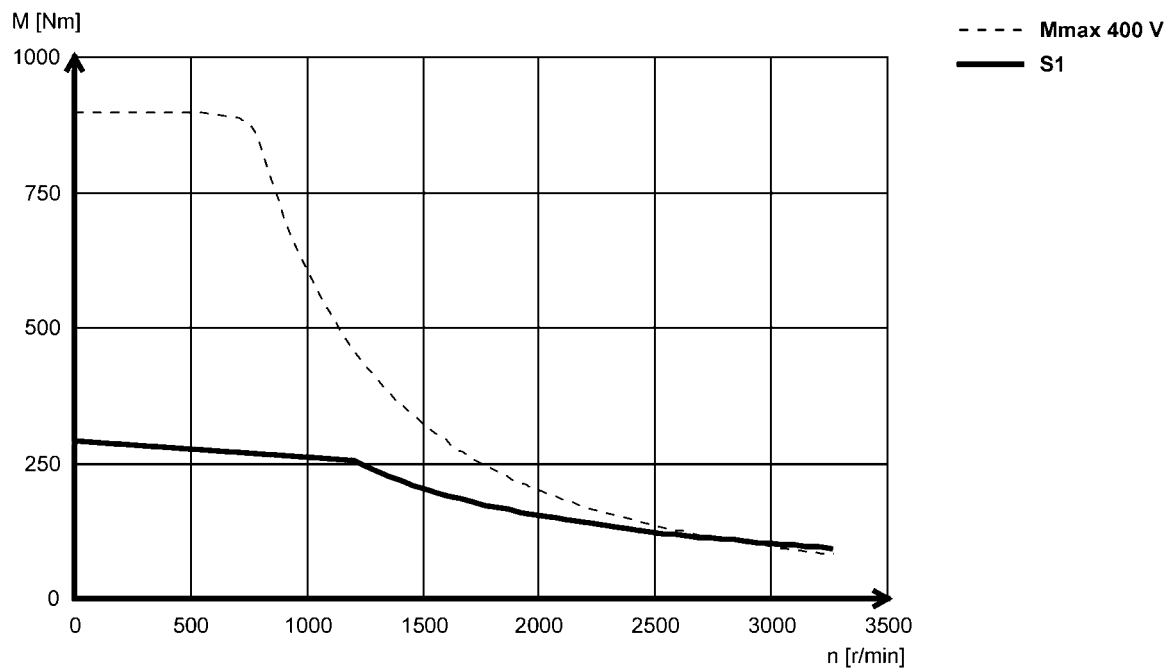

MCA asynchronous servo motors



Technical data

Torque characteristics

- ▶ The data applies to a mains connection voltage of 3 x 400 V.
- ▶ You can find further torque characteristics at Lenze website.

MCA26T22...5F□□ (forced ventilated)

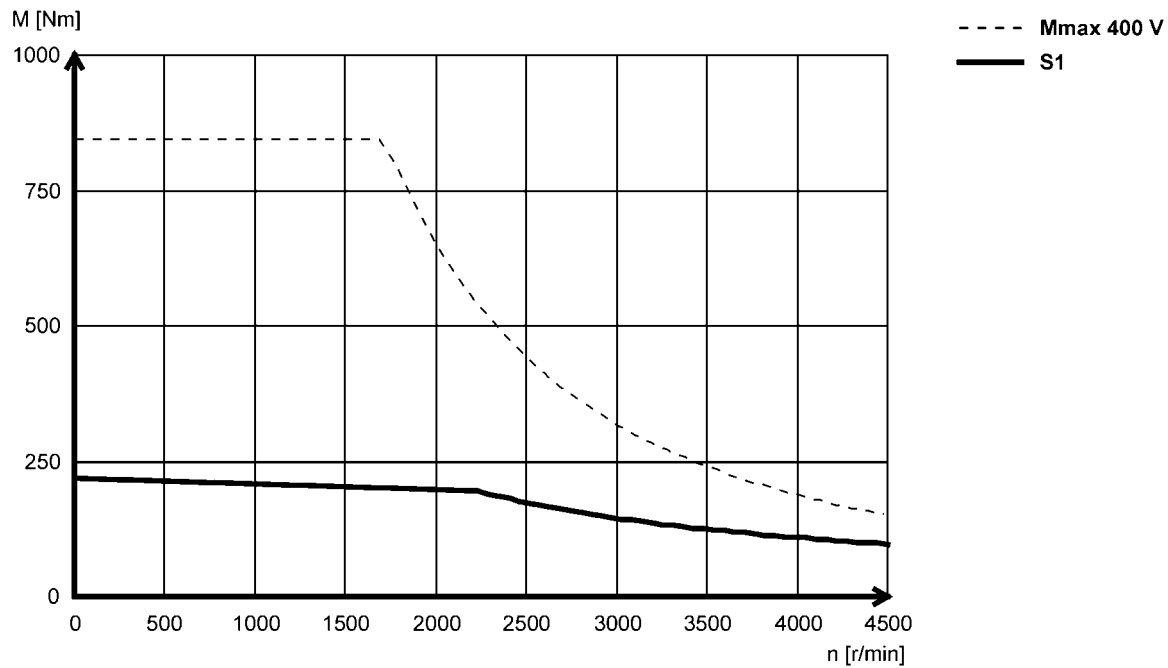

5.4

MCA26T22...2F□□ (forced ventilated)

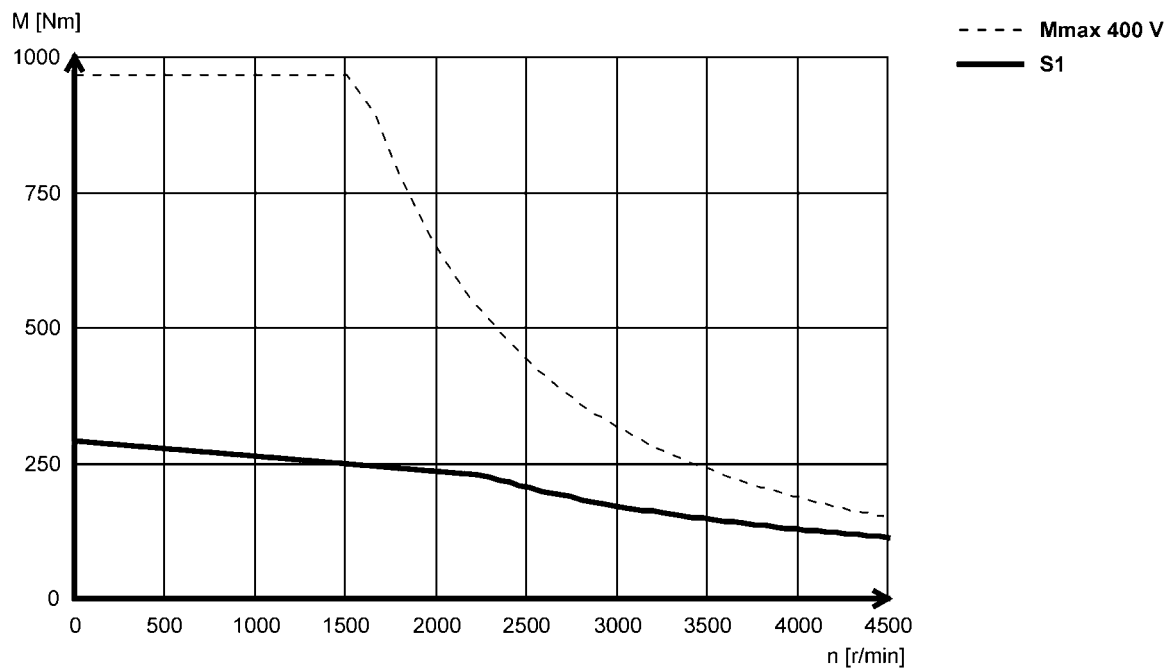

MCA asynchronous servo motors

Technical data



Dimensions, self-ventilated

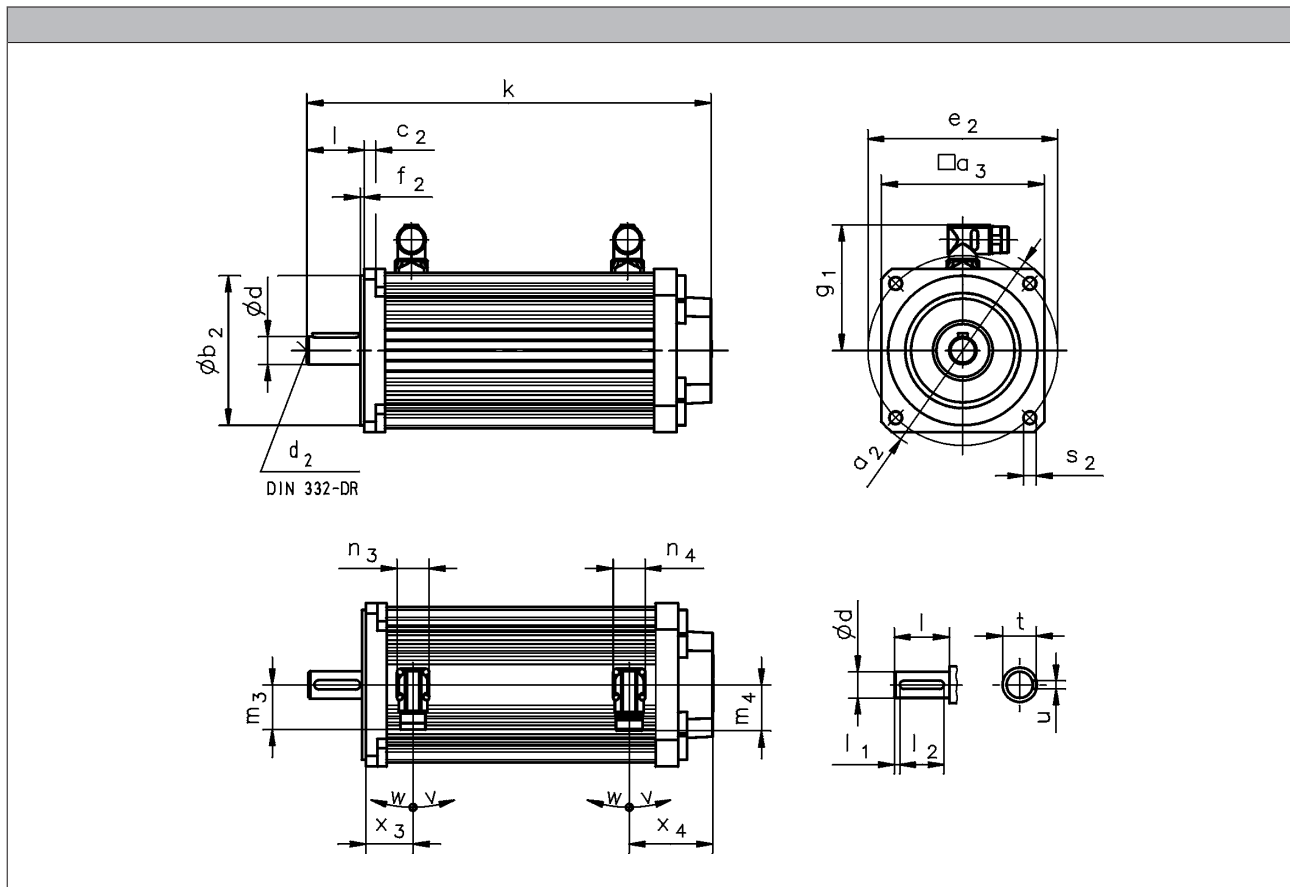

5.4

			MCA10I40	MCA13I41	MCA14L20	MCA17N23	MCA19S23	MCA21X25
					MCA14L41	MCA17N41	MCA19S42	MCA21X42
R□□ B□	k	[mm]	292	311	352	390	461	550
	x ₃	[mm]	37	45	41	43	56	62
	x ₄	[mm]	61	65	73		78	
R□□ P□	k	[mm]	317	346	385	425	499	592
	x ₃	[mm]	59	72	68	75	91	102
	x ₄	[mm]	61	65	73		78	
S□□ / E□□ / T20 / B□	k	[mm]	346	365	407	444	511	599
	x ₃	[mm]	37	45	41	43	56	62
	x ₄	[mm]	115	119	128	127	123	127
S□□ / E□□ / T20 / P□	k	[mm]	371	400	440	479	549	641
	x ₃	[mm]	59	72	68	75	91	102
	x ₄	[mm]	115	119	128	127	123	127

- ▶ Speed/angle sensor: R□□ / S□□ / E□□ / T20
- ▶ Brake: B□ / P□

MCA asynchronous servo motors

Technical data



Dimensions, self-ventilated

	g_1	n_3	n_4	m_3	m_4	v	w
	[mm]	[mm]	[mm]	[mm]	[mm]	[°]	[°]
MCA10I40	90	28	28	40	40	195	80
MCA13I41	102						
MCA14L20	109						
MCA14L41							
MCA17N23	118	40					
MCA17N41							
MCA19S23	151	40	71	71	71	71	
MCA19S42							
MCA21X25							
MCA21X42							

	d	d_2	l	l_1	l_2	u	t
	k_6						
	[mm]	[mm]	[mm]	[mm]	[mm]	[mm]	[mm]
MCA10	14	M5	30	2.5	25	5.0	16.0
MCA13	19	M6	40	2.0	36	6.0	21.5
MCA14	24	M8	50	5.0	40	8.0	27.0
MCA17							
MCA19	28	M10	60		50	31.0	
MCA21	38	M12	80		70	41.0	

	a_2	a_3	b_2	c_2	e_2	f_2	s_2
			j_6				
	[mm]	[mm]	[mm]	[mm]	[mm]	[mm]	[mm]
MCA10	120	102	80	8	100	3.0	7
			70		85	2.5	M6
MCA13	160	130	110	9	130	3.5	9.0
							M8
MCA14	188	142	130	10	165	3.5	11.0
			110		130		M8
MCA17	200	165	130	12	165	3.5	11.0
			110		130		M8
MCA19	250	192	180	11	215	4.0	13.0
			110		130	3.5	M8
MCA21	300	214	180	12	215	4.0	13.0
		250	230		265		
	250	214	110	11	130	3.5	M8

MCA asynchronous servo motors

Technical data



Dimensions, forced ventilated

Motors MCA13 to 19/21

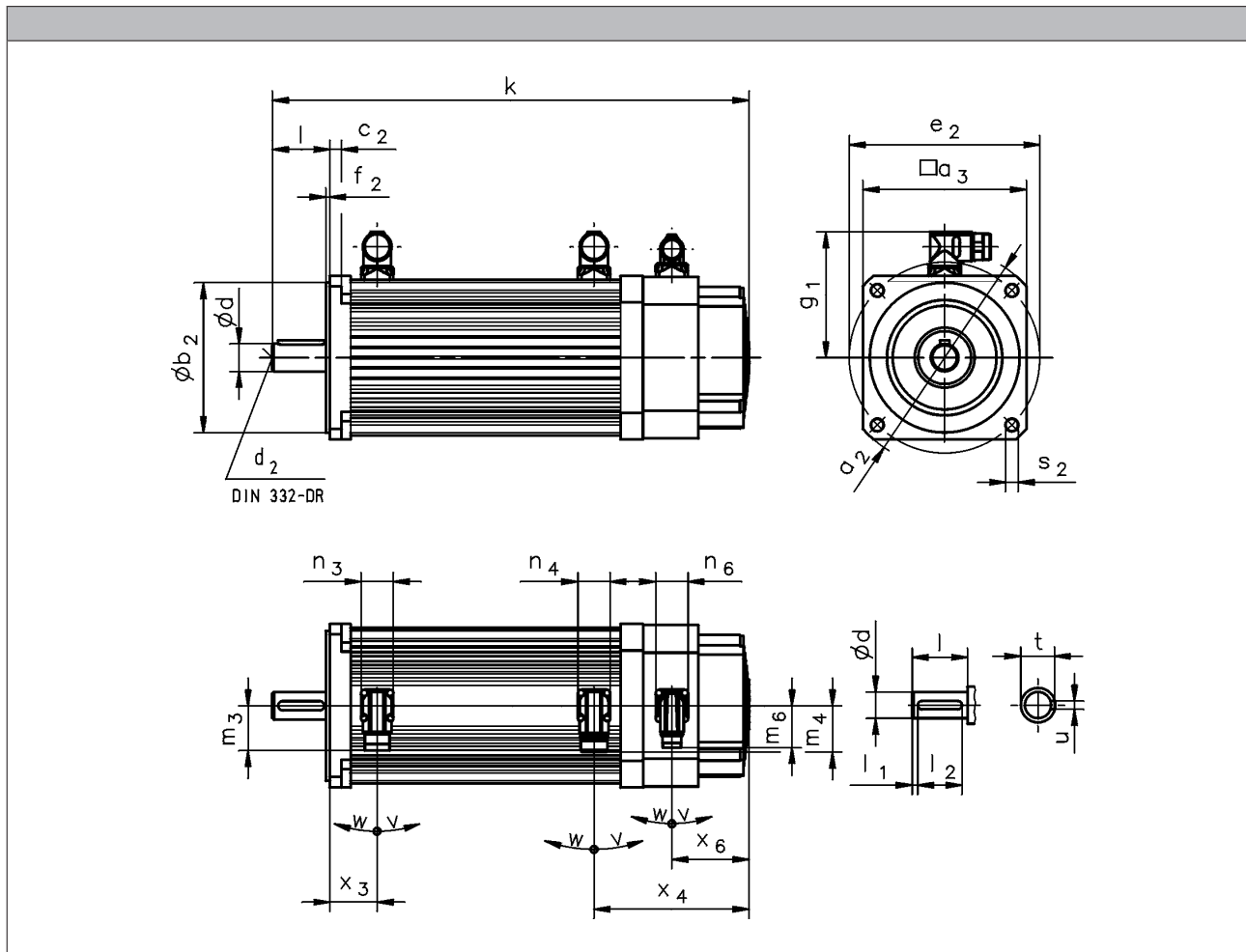

5.4

			MCA13I34	MCA14L16	MCA17N17	MCA19S17	MCA21X17
				MCA14L35	MCA17N35	MCA19S35	MCA21X35
R□□ B□	k	[mm]	379	414	476	558	646
	x ₃	[mm]	45	41	43	56	62
	x ₄	[mm]	133	135	159	170	174
R□□ P□	k	[mm]	414	447	511	596	688
	x ₃	[mm]	72	68	75	91	102
	x ₄	[mm]	133	135	159	170	174
S□□ / E□□ / T20 / B□	k	[mm]	433	469	530	608	695
	x ₃	[mm]	45	41	43	56	62
	x ₄	[mm]	187	190	213	220	223
S□□ / E□□ / T20 / P□	k	[mm]	468	502	565	646	737
	x ₃	[mm]	72	68	75	91	102
	x ₄	[mm]	187	190	213	220	223
	x ₆	[mm]	73	67	94	103	96

- ▶ Speed/angle sensor: RS□ / S□□ / E□□ / T20
- ▶ Brake: B□ / P□

MCA asynchronous servo motors

Technical data



Dimensions, forced ventilated

Motors MCA13 to 19/21

	g ₁ [mm]	n ₃ [mm]	n ₄ [mm]	n ₆ [mm]	m ₃ [mm]	m ₄ [mm]	m ₆ [mm]	v [°]	w [°]
MCA13I34	102	28	28	28	40	40	37	195	80
MCA14L16	109								
MCA14L35	118								
MCA17N17	118								
MCA17N35	151	40			71				
MCA19S17	151								
MCA19S35	162								
MCA21X17	162								
MCA21X35	162								

	d k6 [mm]	d ₂ [mm]	l [mm]	l ₁ [mm]	l ₂ [mm]	u [mm]	t [mm]
MCA13	19	M6	40	2.0	36	6.0	21.5
MCA14	24	M8	50	5.0	40	8.0	27.0
MCA17					50		31.0
MCA19	28	M10	60		70	10.0	41.0
MCA21	38	M12	80				

	a ₂ [mm]	a ₃ [mm]	b ₂ j6 [mm]	c ₂ [mm]	e ₂ [mm]	f ₂ [mm]	s ₂ [mm]
MCA13	160	130	110	9	130	3.5	9.0
			M8				
MCA14	188	142	130	10	165		11.0
			M8				
MCA17	200	165	130	12	165	11.0	
			M8				
MCA19	250	192	180	11	215	4.0	13.0
			M8				
MCA21	300	214	180	12	215	4.0	13.0
		250	230		265		
	250	214	110	11	130	3.5	M8

MCA asynchronous servo motors

Technical data



Dimensions, forced ventilated

MCA20/22/26 motors in B3 design

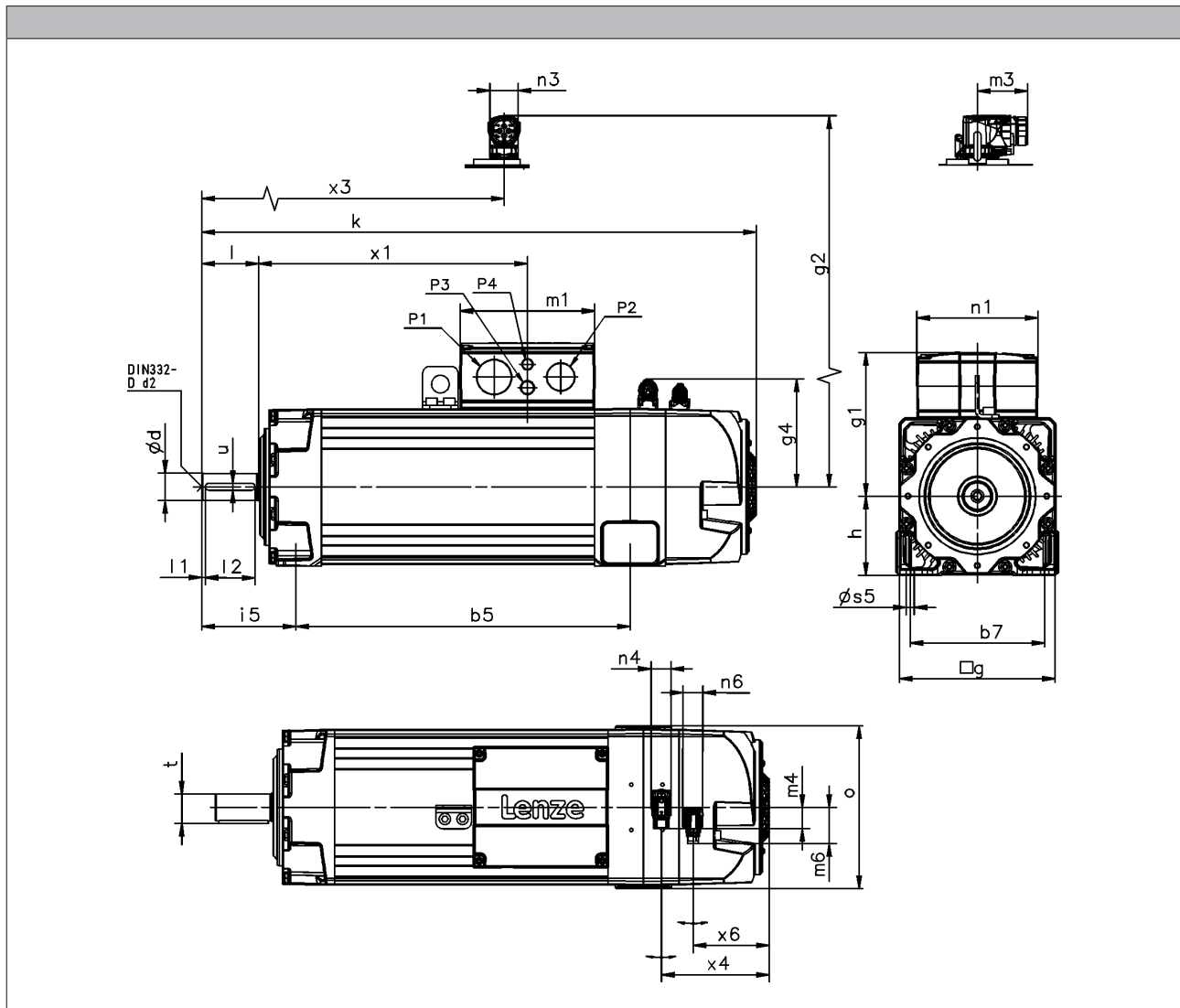

5.4

			MCA20	MCA22	MCA26
R□□ / E□□ / T□□ / S□□ / B0...F10	k	[mm]	666	783	970
R□□ / E□□ / T□□ / S□□ / B0...F1F	k	[mm]	754	865	1022
R□□ / E□□ / T□□ / S□□ / B0	x ₄	[mm]	146	153	194
	m ₄	[mm]	25.0	31.0	25.0
R□□ F1...F10	k	[mm]	753	878	1125
R□□ F1...F1F	k	[mm]	842	959	1177
R□□ F1	x ₄	[mm]	151	157	201
	m ₄	[mm]		31.0	
E□□ / T□□ / S□□ / F1...F10	k	[mm]	797	916	1163
E□□ / T□□ / S□□ / F1...F1F	k	[mm]	885	998	1215
E□□ / T□□ / S□□ / F1	x ₄	[mm]	146	162	200
	m ₄	[mm]		31.0	
R□□ / E□□ / T□□ / S□□ / F2...F10	k	[mm]	822	948	1163
R□□ / E□□ / T□□ / S□□ / F2...F1F	k	[mm]	910	1030	1215
R□□ / E□□ / T□□ / S□□ / F2	x ₄	[mm]	146	162	200
	m ₄	[mm]		31.0	

MCA asynchronous servo motors

Technical data



Dimensions, forced ventilated

MCA20/22/26 motors in B3 design

	g	g ₁	g ₂	g ₄	m ₁	m ₃	m ₆	n ₁	n ₃	n ₄	n ₆
	[mm]	[mm]	[mm]	[mm]	[mm]	[mm]	[mm]	[mm]	[mm]	[mm]	[mm]
MCA20	200	171	168	141	154	72	51	128	40	28	28
MCA22	220	203		153	190			171			
MCA26	260	256		173	234			212			

	o	P ₁	P ₂	P ₃	P ₄	x ₁	x ₃	x ₆
	[mm]	[mm]	[mm]	[mm]	[mm]	[mm]	[mm]	[mm]
MCA20	206	M32x1.5	M25x1.5	M20x1.5		299	422	101
MCA22	230	M50x1.5	M40x1.5		M16x1.5	380		108
MCA26	269	M63x1.5	M50x1.5		465		152	

	d	d	d ₂	l	l ₁	l ₂	u	t
	k6	m6		-0.7 ... 0.3				
	[mm]	[mm]	[mm]		[mm]	[mm]	[mm]	[mm]
MCA20	38		M12	80	5.0	70	10.0	41.0
MCA22						100	16.0	59.0
MCA26		55	M20	110				

	h	b ₅	b ₇	s ₅	i ₅
	[mm]	[mm]	[mm]	[mm]	[mm]
MCA20	100	366	160	11.5	134
MCA22	112	472	190		133
MCA26	132	581	215	14.0	165

- ▶ Speed/angle sensor: RS0 / S□□ / E□□ / T□□
- ▶ Brake: B0 / F1 / F2
- ▶ Blower: F10 / F1F

MCA asynchronous servo motors

Technical data



Dimensions, forced ventilated

MCA20/22/26 motors in B35 design

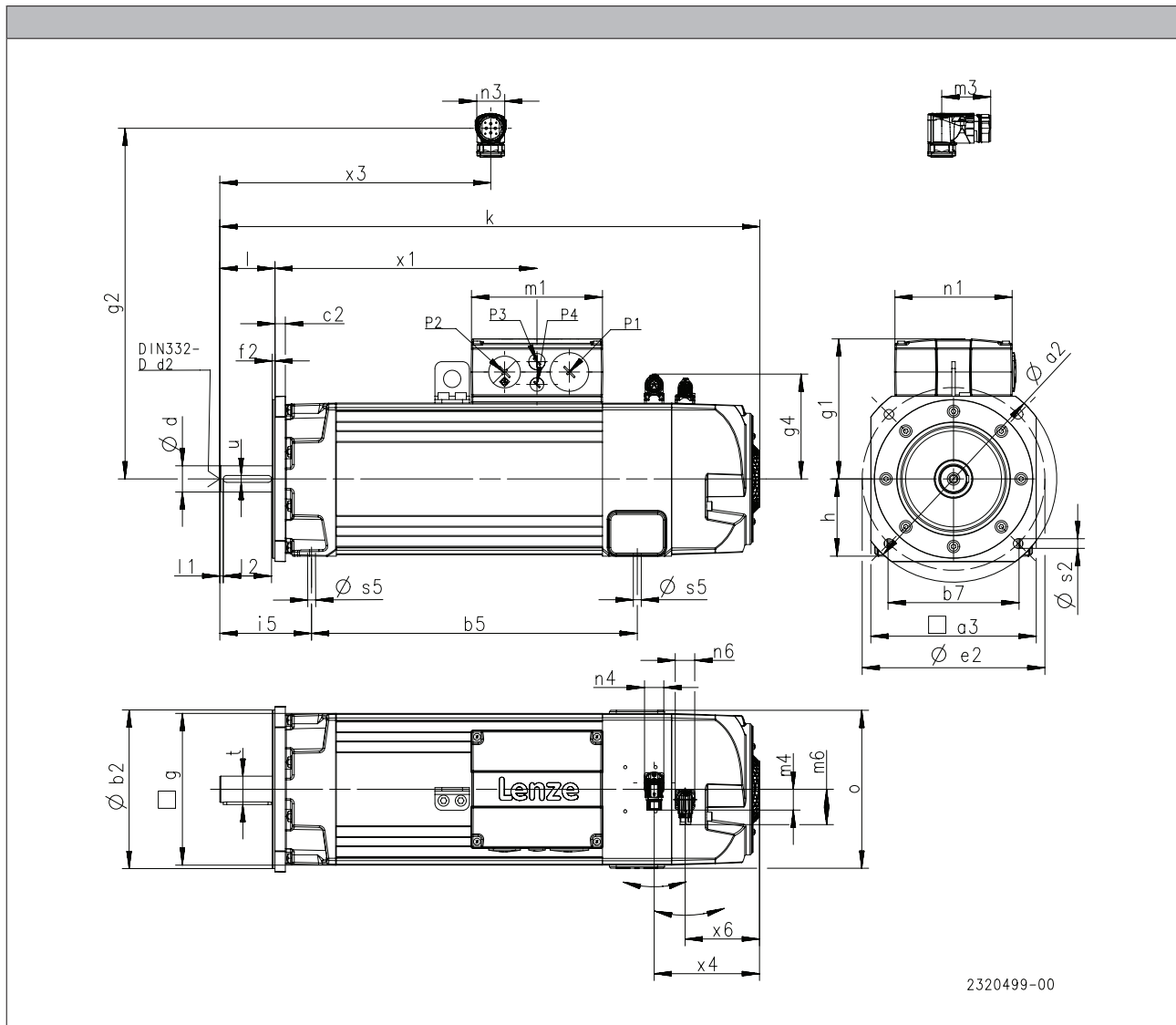

2320499-00

5.4

			MCA20	MCA22	MCA26
R□□ / E□□ / T□□ / S□□ / B0...F10	k	[mm]	666	783	970
R□□ / E□□ / T□□ / S□□ / B0...F1F	k	[mm]	754	865	1022
R□□ / E□□ / T□□ / S□□ / B0	x ₄	[mm]	146	153	194
	m ₄	[mm]	25.0	31.0	25.0
R□□ F1...F10	k	[mm]	753	878	1125
R□□ F1...F1F	k	[mm]	842	959	1177
R□□ F1	x ₄	[mm]	151	157	201
	m ₄	[mm]		31.0	
E□□ / T□□ / S□□ / F1...F10	k	[mm]	797	916	1163
E□□ / T□□ / S□□ / F1...F1F	k	[mm]	885	998	1215
E□□ / T□□ / S□□ / F1	x ₄	[mm]	146	162	200
	m ₄	[mm]		31.0	
R□□ / E□□ / T□□ / S□□ / F2...F10	k	[mm]	822	948	1163
R□□ / E□□ / T□□ / S□□ / F2...F1F	k	[mm]	910	1030	1215
R□□ / E□□ / T□□ / S□□ / F2	x ₄	[mm]	146	162	200
	m ₄	[mm]		31.0	

MCA asynchronous servo motors

Technical data



Dimensions, forced ventilated

MCA20/22/26 motors in B35 design

	g	g ₁	g ₂	g ₄	m ₁	m ₃	m ₆	n ₁	n ₃	n ₄	n ₆
	[mm]	[mm]	[mm]	[mm]	[mm]	[mm]	[mm]	[mm]	[mm]	[mm]	[mm]
MCA20	200	171	168	141	154	72	51	128	40	28	28
MCA22	220	203		153	190			171			
MCA26	260	256		173	234			212			

	o	P ₁	P ₂	P ₃	P ₄	x ₁	x ₃	x ₆
	[mm]	[mm]	[mm]	[mm]	[mm]	[mm]	[mm]	[mm]
MCA20	206	M32x1.5	M25x1.5	M20x1.5	M16x1.5	299	422	101
MCA22	230	M50x1.5	M40x1.5			380		108
MCA26	269	M63x1.5	M50x1.5			465		152

	d	d	d ₂	l	l ₁	l ₂	u	t
	k6	m6		-0.7 ... 0.3				
	[mm]	[mm]	[mm]		[mm]	[mm]	[mm]	[mm]
MCA20	38		M12	80	5.0	70	10.0	41.0
MCA22								
MCA26		55	M20	110		100	16.0	59.0

	h	b ₅	b ₇	s ₅	i ₅
	[mm]	[mm]	[mm]	[mm]	[mm]
MCA20	100	366	160	11.5	134
MCA22	112	472	190		133
MCA26	132	581	215	14.0	165

	a ₂	a ₃	b ₂	b ₂	c ₂	e ₂	f ₂	s ₂
			j6	h6				
	[mm]	[mm]	[mm]	[mm]	[mm]	[mm]	[mm]	[mm]
MCA20	250	196	180	300	15	215	4.0	14
MCA22	300	240	230			265		
MCA26	400	320				350	5.0	18

- ▶ Speed/angle sensor: RS0 / S□□ / E□□ / T□□
- ▶ Brake: B0 / F1 / F2
- ▶ Blower: F10 / F1F

MCA asynchronous servo motors

Technical data

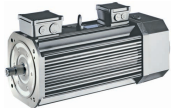



Permanent magnet holding brake

The asynchronous servo motors MCA10 to 19 and 21 can be fitted with integral permanent magnet holding brakes. In the case of permanent magnet brakes, the rated torque applies solely as holding torque at standstill. This is due to the nature of their design. During braking from full motor speed, e.g. in the event of emergency stops, the braking torque is significantly reduced. As such, they may not be used as safety elements (particularly with lifting axes) without additional measures being implemented. The brakes are activated when the supply voltage is disconnected (closed-circuit principle). When using the brakes purely as holding brakes, virtually no wear occurs on the friction surfaces.

For traversing axes, adherence to the permissible load/brake motor (J_L / J_{MB}) moment of inertia ensures that the permissible maximum switching rate of the brake will not be exceeded and at least 2,000 emergency stop functions can be performed from a speed of 3,000 rpm.

For lifting axes, the load torque resulting from the weight acts additionally. In this case the specifications for J_L / J_{MB} do not apply.

Caution:

The brakes used are not safety brakes in the sense that a reduction in torque may arise as a result of disruptive factors that cannot be influenced, e.g. oil ingress.

The ohmic voltage drop along the cable must be taken into consideration in long motor supply cables and must be compensated for by a higher voltage at the line input.

The following applies for Lenze system cables:

$$U[V] = U_B[V] + 0.08 \frac{[V]}{[A] \cdot [m]} \cdot l_{lg}[m] \cdot I_B[A]$$

If no suitable voltage (incorrect value, incorrect polarity) is applied to the brake, the brake will be applied and can be overheated and destroyed by the motor continuing to rotate.

The shortest switching times of the brakes are achieved by DC switching of the voltage. A spark suppressor is required to suppress interference and to increase the service life of the relay contacts here.



Permanent magnet holding brake



Permanent magnet holding brake

Rated data with standard braking torque

- The figures stated apply to servo motors. They only apply to geared servo motors when the servo motor is connected via a mounting flange.

	U _{N,DC} ^{3,4,7)}	U _{N,AC} ^{5,7)}	M _N	M _N	M _{av}	I _N ²⁾	J	t ₁ ¹⁾	t ₂ ¹⁾	Q _E ⁶⁾	m	J _{MB}	J _L /J _{MB}
			20 °C	120 °C	120 °C								
	[V]	[V]	[Nm]	[Nm]	[Nm]	[A]	[kgcm ²]	[ms]	[ms]	[J]	[kg]	[kgcm ²]	
MCA10	24		3.30	2.50	1.20	0.50	0.38	10.0	20.0	350	0.90	2.78	24.5
	205					0.060							
MCA13	24		12.0	11.0	5.50	0.67	1.06	20.0	29.0	400	0.80	9.36	7.70
	205					0.080							
MCA14	24		15.0	12.0	6.00	0.75	3.60	13.0	30.0	700	1.50	22.8	5.20
	205					0.090							
MCA17	24		24.0	22.0	11.0	0.75	9.50	25.0	50.0	1200	2.70	81.5	3.70
	205					0.090							
MCA19	24		46.0	40.0	18.0	1.00	31.8	53.0	97.0	2800	5.00	212	1.70
	205					0.12							
MCA21	24		88.0	80.0	35.0	1.46	31.8	53.0	97.0	2800	5.00	212	1.70
	205					0.18							

- ¹⁾ Engagement and disengagement times are valid for rated voltage ($\pm 0\%$) and protective circuit for brakes with varistor for DC switching. The times may increase without a protective circuit.
- ²⁾ The currents are the maximum values when the brake is cold (value used for dimensioning the current supply). The values for a motor at operating temperature are considerably lower.
- ³⁾ With 24 V DC brake: smoothed DC voltage, ripple $\leq 1\%$.
With 205 V DC brake: connection to 230 V AC through rectifier.
- ⁴⁾ UR not possible in the case of a brake with a 205 V supply voltage.
- ⁵⁾ UR not possible in the case of a brake with 230 V supply voltage.
- ⁶⁾ Maximum switching energy per emergency stop at $n = 3000$ r/min for at least 2000 emergency stops.
- ⁷⁾ Voltage tolerance: permanent magnet brakes -10% to +5%
spring-applied brakes $\pm 10\%$



Permanent magnet holding brake

Rated data with increased braking torque

- These ratings apply only for geared servo motors with integrated servo motor (without mounting flange).

	$U_{N,DC}^{3,4,7)}$	M_N	M_N	M_{av}	$I_N^{2)}$	J	$t_1^{1)}$	$t_2^{1)}$	$Q_E^{6)}$	m	J_{MB}	J_L/J_{MB}
		20 °C	120 °C	120 °C								
	[V]	[Nm]	[Nm]	[Nm]	[A]	[kgcm ²]	[ms]	[ms]	[J]	[kg]	[kgcm ²]	
MCA10	24	6.00	5.00	2.50	0.67	1.06	20.0	29.0	400	0.80	3.46	22.4
	205				0.80							
MCA13	24	15.0	12.0	6.00	0.75	3.60	13.0	30.0	700	1.50	11.9	8.40
	205				0.090							
MCA14	24	23.0	20.0	20.0	0.92	9.50	18.0	55.0	1350	2.40	22.8	6.60
	205				0.12							
MCA17	24				0.92						45.5	5.00
	205				0.12							
MCA19	24	48.0	40.0		31.8	1.46	30.0	100	2800	4.80	104	4.50
	205					0.18						
MCA21	24	88.0	80.0	35.0		1.46	53.0	97.0	2800	5.00	212	1.70
	205					0.18						

- 1) Engagement and disengagement times are valid for rated voltage ($\pm 0\%$) and protective circuit for brakes with varistor for DC switching. The times may increase without a protective circuit.
- 2) The currents are the maximum values when the brake is cold (value used for dimensioning the current supply). The values for a motor at operating temperature are considerably lower.
- 3) With 24 V DC brake: smoothed DC voltage, ripple $\leq 1\%$.
With 205 V DC brake: connection to 230 V AC through rectifier.
- 4) UR not possible in the case of a brake with a 205 V supply voltage.
- 5) UR not possible in the case of a brake with 230 V supply voltage.
- 6) Maximum switching energy per emergency stop at $n = 3000$ r/min for at least 2000 emergency stops.
- 7) Voltage tolerance: permanent magnet brakes -10% to +5%
spring-applied brakes $\pm 10\%$

MCA asynchronous servo motors

Accessories



Spring-applied holding brake

Spring-operated holding brakes are available for the asynchronous servo motors MCA20, 22 and 26.

The brakes are activated when the supply voltage is disconnected (closed-circuit principle). When using the brakes purely as holding brakes, virtually no wear occurs on the friction surfaces.

Caution:

The brakes used are not safety brakes in the sense that a reduction in torque may arise as a result of disruptive factors that cannot be influenced, e.g. oil ingress.

The ohmic voltage drop along the cable must be taken into consideration in long motor supply cables and must be compensated for by a higher voltage at the line input.

The following applies for Lenze system cables:

$$U[V] = U_B[V] + 0.08 \frac{[V]}{[A] \cdot [m]} \cdot l_{lg}[m] \cdot I_B[A]$$

If no suitable voltage (incorrect value, incorrect polarity) is applied to the brake, the brake will be applied and can be overheated and destroyed by the motor continuing to rotate.

The shortest switching times of the brakes are achieved by DC switching of the voltage. A spark suppressor is required to suppress interference and to increase the service life of the relay contacts here.



Spring-applied holding brake

MCA asynchronous servo motors



Accessories

Spring-applied holding brake

Rated data with standard braking torque

- The figures stated apply to servo motors. They only apply to geared servo motors when the servo motor is connected via a mounting flange.

	U _{N,DC} ^{3,4,7)}	U _{N,AC} ^{5,7)}	M _N	M _N	M _{av}	I _N ²⁾	J	t ₁ ¹⁾	t ₂ ¹⁾	Q _E ⁶⁾	m	J _{MB}	J _L /J _{MB}
			20 °C	120 °C	120 °C								
	[V]	[V]	[Nm]	[Nm]	[Nm]	[A]	[kgcm ²]	[ms]	[ms]	[J]	[kg]	[kgcm ²]	
MCA20	24	230	90.0	80.0	50.0	3.13	6.88	70.0	220	18000	13.0	177	19.6
	0.37												
MCA22	24	230	150	130	80.0	3.75	18.1	50.0	260	23000	20.5	505	8.20
	0.44					130							
MCA26	24	230	300	260	160	3.75	36.3	175	320	39000	26.0	1405	12.7
	0.37				70.4	360			51000				

Rated data with increased braking torque

- The figures stated apply to servo motors. They only apply to geared servo motors when the servo motor is connected via a mounting flange.

	U _{N,DC} ^{3,4,7)}	U _{N,AC} ^{5,7)}	M _N	M _N	M _{av}	I _N ²⁾	J	t ₁ ¹⁾	t ₂ ¹⁾	Q _E ⁶⁾	m	J _{MB}	J _L /J _{MB}
			20 °C	120 °C	120 °C								
	[V]	[V]	[Nm]	[Nm]	[Nm]	[A]	[kgcm ²]	[ms]	[ms]	[J]	[kg]	[kgcm ²]	
MCA20	24	230	150	130	100	2.58	14.1	70.0	240	31000	15.4	189	33.0
	0.30												
MCA22	24	230	300	260	160	3.75	36.3	175	320	39000	26.0	523	14.1
	0.44					130		310					
MCA26	24	230	500	430	260	3.75	70.4	175	390	51000	30.8	1405	12.7
	0.44												

- 1) Engagement and disengagement times are valid for rated voltage ($\pm 0\%$) and protective circuit for brakes with varistor for DC switching. The times may increase without a protective circuit.
- 2) The currents are the maximum values when the brake is cold (value used for dimensioning the current supply). The values for a motor at operating temperature are considerably lower.
- 3) With 24 V DC brake: smoothed DC voltage, ripple $\leq 1\%$.
With 205 V DC brake: connection to 230 V AC through rectifier.
- 4) UR not possible in the case of a brake with a 205 V supply voltage.
- 5) UR not possible in the case of a brake with 230 V supply voltage.
- 6) Maximum switching energy per emergency stop at $n = 3000$ r/min for at least 2000 emergency stops.
- 7) Voltage tolerance: permanent magnet brakes -10% to +5%
spring-applied brakes $\pm 10\%$

MCA asynchronous servo motors

Accessories



Resolver

Stator-fed resolver with two stator windings offset by 90° and one rotor winding with transformer winding.

Speed/angle sensor				RS0	RV0
	1)				
Product key				RS0	RV03
Resolution					
Angle			[°]	0.80	
Accuracy					
			[°]	-10 ... 10	
Absolute positioning					
				1 revolution	
Max. speed					
	n_{max}		[r/min]	8000	
Max. input voltage					
DC	$U_{in,max}$		[V]	10.0	
Max. input frequency					
	$f_{in,max}$		[Hz]	4.00	
Ratio					
Stator / rotor			± 5 %	0.30	
Rotor impedance					
	Z_{ro}		[Ω]	51 + j90	
Stator impedance					
	Z_{so}		[Ω]	102 + j150	
Impedance					
	Z_{rs}		[Ω]	44 + j76	
Min. insulation resistance					
At DC 500 V	R		[Ω]	10.0	
Number of pole pairs					
				1	
Max. angle error					
			[°]	-10 ... 10	
Inverter assignment					
				E84AVTC E94A ECS EVS93	

1) 6 - Product key > speed/angle sensor

Speed-dependent safety functions

Suitable for safety function				No	Yes
Max. permissible angular acceleration					
MCA10 ... MCA19 ²⁾	α		[rad/s ²]		22 000
MCA20 ... MCA26 ²⁾	α		[rad/s ²]		22 000
Functional safety					
IEC 61508					SIL3
EN 13849-1					Up to Performance Level e

2) 1 - Single encoder concepts with resolvers

MCA asynchronous servo motors

Accessories



Incremental encoder and SinCos absolute value encoder

Encoder type			TTL incremental		SinCos incremental	
Speed/angle sensor			T20	T40	S20	S15
Product key			IG2048-5V-T	IG4096-5V-T	IG2048-5V-S	IG1024-5V-V3
Encoder type			Single-turn			
Pulses			2048	4096	2048	1024
Output signals			TTL		1 V _{ss}	
Interfaces			A, B, N track and inverted			
Absolute revolutions			0			
Resolution						
Angle ²⁾		[°]	2.60	1.30	0.40	
Accuracy		[°]	-2 ... 2		-0.8 ... 0.8	
Min. input voltage						
DC	U _{in,min}	[V]	4.75		4.50	4.75
Max. input voltage						
DC	U _{in,max}	[V]	5.25		5.50	5.25
Max. speed						
	n _{max}	[r/min]	8789		5273	8000
Max. current consumption						
	I _{max}	[A]	0.15		0.10	0.070
Limit frequency						
	f _{max}	[kHz]	300		180	200
Inverter assignment			E84AVTC E94A ECS EVS93			E94A

¹⁾ 6 - Product key > speed/angle sensor

²⁾ Inverter-dependent.

Speed-dependent safety functions

Suitable for safety function			No	No	No	Yes
Max. permissible angular acceleration						
MQA20 ... MQA26	α	[rad/s ²]				73 000
Functional safety						
IEC 61508						SIL3
EN 13849-1						Up to Performance Level e

MCA asynchronous servo motors

Accessories



Incremental encoder and SinCos absolute value encoder

Encoder type			SinCos absolute value				
Speed/angle sensor			EQI	SRS	SRM	ECN	EQN
Product key			AM32-5V-E	AS1024-8V-H	AM1024-8V-H	AS2048-5V-E	AM2048-5V-E
Encoder type			Multi-turn	Single-turn	Multi-turn	Single-turn	Multi-turn
Pulses			32	1024		2048	
Output signals			1 Vss				
Interfaces			EnDat	Hiperface		EnDat	
Absolute revolutions			4096	1	4096	1	4096
Resolution							
Angle			[°]				
Accuracy			[°]				
Min. input voltage			[V]				
DC			4.75	7.00	4.75		
Max. input voltage			[V]				
DC			5.25	12.0	5.25		
Max. speed			[r/min]				
			12000	6000	12000		
Max. current consumption			[A]				
			0.17	0.080	0.15	0.25	
Limit frequency			[kHz]				
			6.00	200			
Inverter assignment			E94A	E84AVTC E94A ECS EVS93		E94A	

1) 6 - Product key > speed/angle sensor

MCA asynchronous servo motors

Accessories



Blowers

Rated data for 50 Hz

		Degree of protection	Number of phases	U_{min} [V]	U_{max} [V]	$U_{N, AC}$ [V]	P_N [kW]	I_N [A]
MCA13	F10	IP54	1	210	240	230	0.019	0.12
MCA14							0.040	0.25
MCA17							0.17	0.73
MCA19							0.060	0.26
MCA20	F10 F1F	IP23s			250		0.24	1.05
MCA21	F10	IP54			240		0.40	1.75
MCA22	F10	IP54			250			
MCA26	F1F	IP23s						

Rated data for 60 Hz

		Degree of protection	Number of phases	U_{min} [V]	U_{max} [V]	$U_{N, AC}$ [V]	P_N [kW]	I_N [A]
MCA13	F10	IP54	1	210	240	230	0.019	0.12
MCA14							0.040	0.25
MCA17							0.20	0.90
MCA19							0.060	0.26
MCA20	F10 F1F	IP23s			250		0.28	1.23
MCA21	F10	IP54			240		0.41	1.82
MCA22	F10	IP54			250			
MCA26	F1F	IP23s						



Temperature monitoring

The thermal sensors (1x KTY 83-110) used continuously monitor the motor temperature. The temperature signal is transmitted over the system cable of the feedback system to the servo controller. This means that the temperature of the motor is determined with great accuracy in the permitted operating range and at the same time the overtemperature response configured in the controller is executed in the event of overtemperature in one of the winding phases.

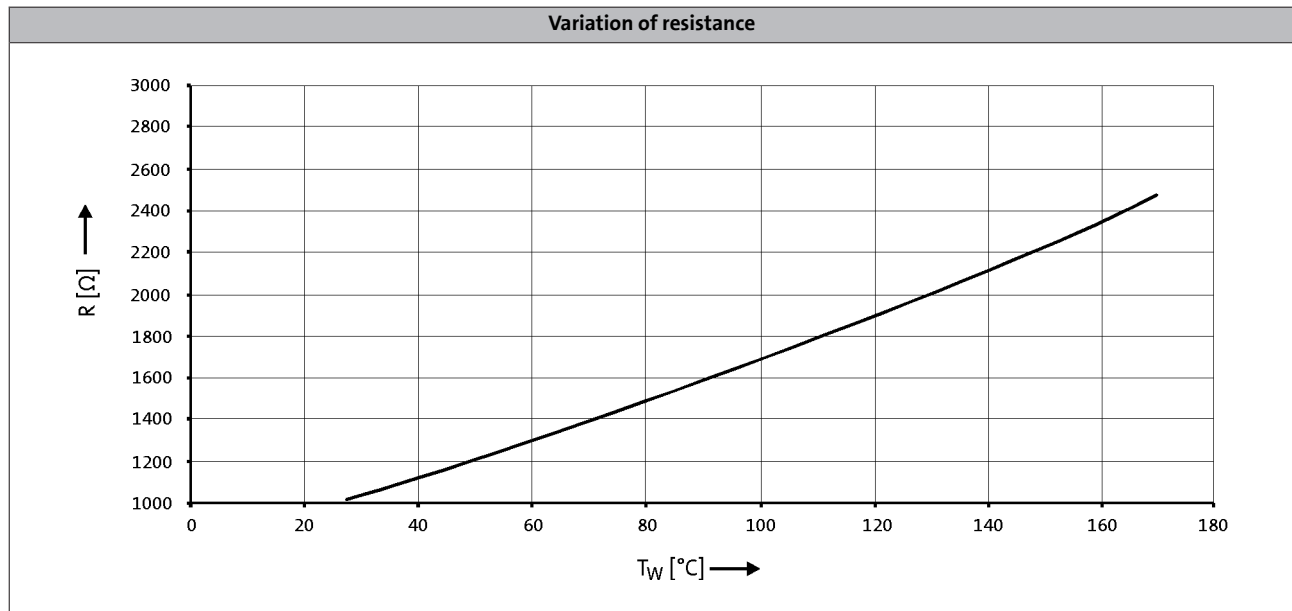

- If the detector is supplied with a measured current of 1 mA, the above relationship between the temperature and the resistance applies.

MCA asynchronous servo motors

Accessories



Terminal box

Motors MCA10 to 19/21

If a servo motor is to be connected to an existing cable or plug connectors are not to be used for other reasons, the connection can also be made via a terminal box.

The motor can either be fitted with a terminal box for the power connection and motor holding brake or a second terminal box provided to connect the motor feedback and blower (if applicable).

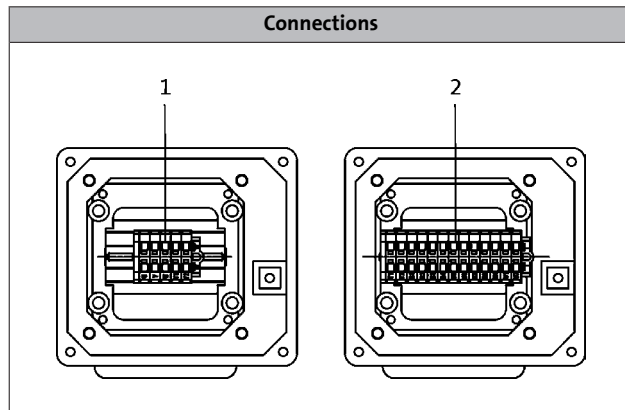

1: Power connection + brake connection + PE connection.

2: Angle/speed sensor connection + thermal sensor connection

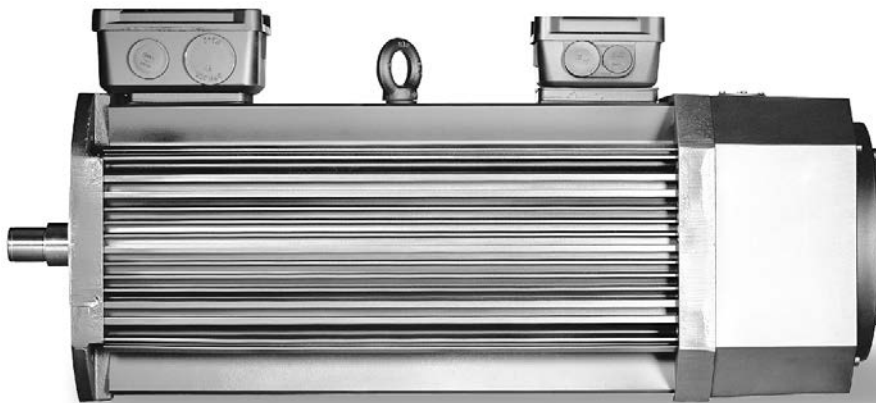

MCA asynchronous servo motors with blower and terminal box

MCA asynchronous servo motors

Accessories



Terminal box

Motors MCA10 to 19/21

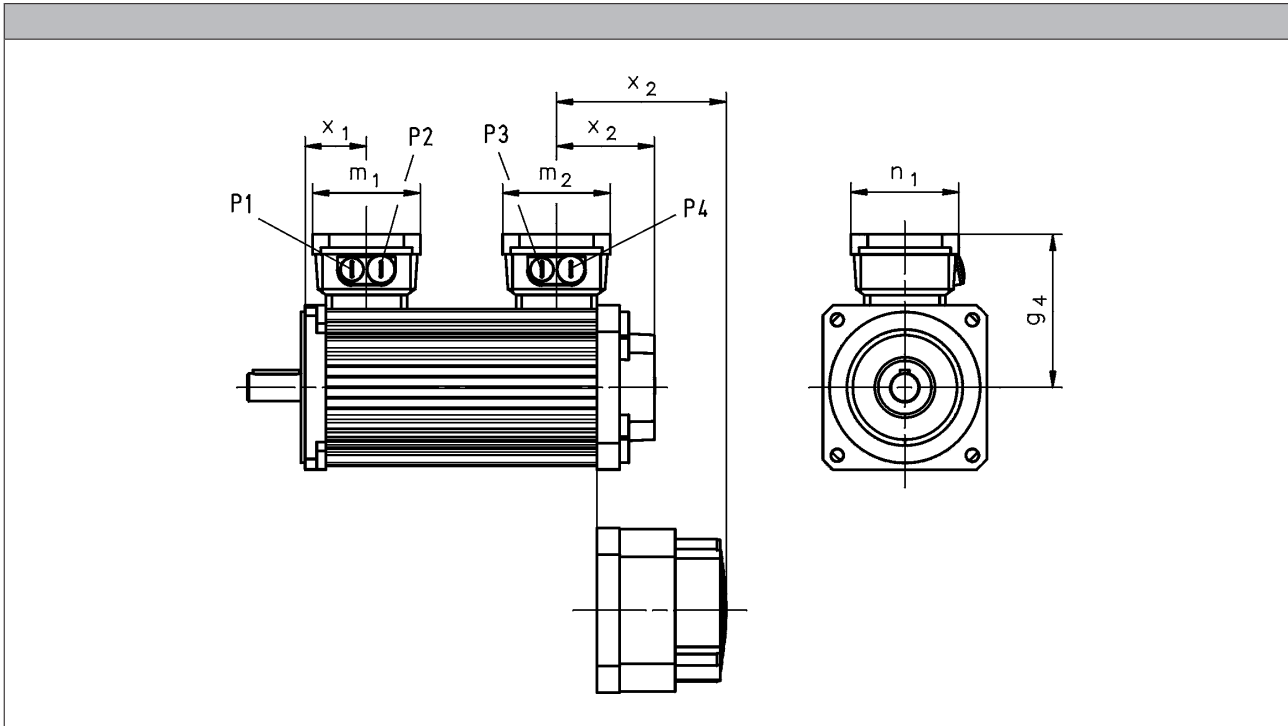

5.4

			MCA10I40	MCA13I41	MCA14L20	MCA17N23	MCA19S23	MCA21X25
					MCA14L41	MCA17N41	MCA19S42	MCA21X42
R□0 B0	x ₂	[mm]	78	77	85		93	97
R□0 P□	x ₂	[mm]	78	77	85		93	97
S□□ / E□□ / T20 / B0	x ₂	[mm]	132	131	140	139	143	147
S□□ / E□□ / T20 / P□	x ₂	[mm]	132	131	140	139	143	147

			MCA13I34	MCA14L16	MCA17N17	MCA19S17	MCA21X17
				MCA14L35	MCA17N35	MCA19S35	MCA21X35
R□0 B0	x ₂	[mm]	145	147	171	190	193
R□0 P□	x ₂	[mm]	145	147	171	190	193
S□□ / E□□ / T20 / B0	x ₂	[mm]	199	202	225	240	243
S□□ / E□□ / T20 / P□	x ₂	[mm]	199	202	225	240	243

- ▶ Speed/angle sensor: R50 / S□□ / E□□ / T20
- ▶ Brake: B0 / P□

	g ₄	m ₁	m ₂	n ₁	x ₁	P ₁	P ₂	P ₃	P ₄
	[mm]	[mm]	[mm]	[mm]	[mm]	[mm]	[mm]	[mm]	[mm]
MCA10	113	93	93	93	54	M20x1.5	M20x1.5	M20x1.5	M20x1.5
MCA13	125				57				
MCA14	133				53				
MCA17	141				55				
MCA19	158	115	115	115	64	M25x1.5	M32x1.5	M25x1.5	M20x1.5
MCA21	169				70				

MCA asynchronous servo motors



Accessories

ICN connector

Servo motors MCA10 to 21 provide ICN connectors as standard for electrical connection. Servo motors MCA22 and MCA26 provide a terminal box for electrical connection.

A connector is used for the connection of motor and brake. The connections to the feedback system/temperature monitoring and the blower each employ a separate connector.

The connectors can be rotated through 270° and are fitted with a bayonet catch for SpeedTec connectors. As the connector fixing is also compatible with conventional union nuts. Existing mating connectors can therefore still be used without difficulty.

Connection for power and brake

► MCA10 to 17

Pin assignment		
Contact	Designation	Meaning
1	BD1	Holding brake +
2	BD2	Holding brake -
PE	PE	PE conductor
4	U	Phase U power
5	V	Phase V power
6	W	Phase W power

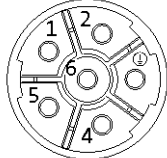

► MCA19 to 21

Pin assignment		
Contact	Designation	Meaning
1		Not assigned
2		
+	BD1	Holding brake +
-	BD2	Holding brake -
PE	PE	PE conductor
U	U	Phase U power
V	V	Phase V power
W	W	Phase W power

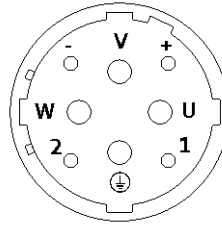

MCA asynchronous servo motors



Accessories

ICN connector

Feedback connection

► Resolver

Pin assignment		
Contact	Designation	Meaning
1	+Ref	Transformer windings
2	-Ref	
3	+VCC ETS	Supply: Electronic nameplate
4	+COS	Cosine stator windings
5	-COS	
6	+SIN	Sine stator windings
7	-SIN	
8		Not assigned
9		
10		
11	+KTY	KTY temperature sensor
12	-KTY	

► Hiperface incremental encoder and SinCos absolute value encoder

Pin assignment		
Contact	Designation	Meaning
1	B	Track B/+SIN
2	A ⁻	Track A inverse/-COS
3	A	Track A/+COS
4	+U _B	Supply +
5	GND	Mass
6	Z ⁻	Zero track inverse/-RS485
7	Z	Zero track/+RS485
8		Not assigned
9	B ⁻	Track B inverse/-SIN
10		Not assigned
11	+KTY	KTY temperature sensor
12	-KTY	

MCA asynchronous servo motors

Accessories



ICN connector

Feedback connection

- SinCos absolute value encoder with EnDat interface

Pin assignment		
Contact	Designation	Meaning
1	U _p sensor	Supply: UP sensor
2		Not assigned
3		
4	0 V sensor	Supply: 0 V sensor
5	+KTY	KTY temperature sensor
6	-KTY	
7	+U _B	Supply +
8	Cycle	EnDat interface cycle
9	Cycle ⁻	EnDat interface inverse cycle
10	GND	Mass
11	Shield	Encoder housing screen
12	B	Track B
13	B ⁻	Track B inverse/-SIN
14	Data	EnDat interface data
15	A	Track A
16	A ⁻	Track A inverse
17	Data ⁻	EnDat interface inverse data

Blower connection

Pin assignment		
Contact	Designation	Meaning
PE	PE	PE conductor
1	U1	Fan
2	U2	
3		Not assigned
4		
5		
6		